



GET STARTED BOOKLET

How to get started with Infento Education



WELCOME TO THE GET STARTED BOOKLET

Below you find the contents of this booklet. There are 6 chapters that can be relevant, please see below an overview that shows if a chapter is relevant to read depending on the Kit you purchased. Tip: The list contains links that take you directly to the corresponding pages.

TABLE OF CONTENTS

- 3 [General checklist](#)
- 5 [Prepare and organize](#)
- 12 [Pre-building instructions](#)
- 18 [ePulse checklist](#)
- 22 [ePulse instructions](#)
- 32 [Building tips](#)

RELEVANT FOR YOUR EDUCATION KIT

Check the table to see which sections of the guide are relevant to you, depending on the Kit you have. Tip: Again the checklist names feature link to automatically direct you to the correct page.

Product (Kit)	General checklist	Pre-building instructions	ePulse checklist	ePulse Instructions	Building tips
Pro Kit 2	✓	✓	✓	✓	✓
Nexus Kit	✓	✓	✗	✗	✓

GET STARTED WITH YOUR INFENTO EDUCATION KIT

General checklists

- 4 Check the boxes of your Kit
- 5 Check your printed materials



CHECK THE BOXES OF YOUR KIT

Before starting, complete this checklist to ensure everything is in order.

<input type="checkbox"/>	Verify your Kit's SKU boxes
<input type="checkbox"/>	Verify your Kit's grey boxes
<input type="checkbox"/>	Check and count bolt & nut bags
<input type="checkbox"/>	Check ePulse system and battery (Pro Kit 2 only , go to page 12)

1

Verify your Kit's SKU shipping boxes

Find the label, on the side of the brown shipping box and ensure the SKU names.

Product (Kit)	Quantity of boxes	SKU name
Pro Kit 2	4	PRO2_1/4 + PRO2_2/4 + PRO2_3/4 + PRO2_4/4
Nexus Kit	2	NEX_1/2 + NEX_2/2

2

Verify your Kit's grey boxes

Check the sticker on the grey box; numbers must match and the SKU name is printed vertically in white.

Product (Kit)	Quantity of boxes	SKU name
Pro Kit 2	10	PRO2_1.WHE + PRO2_2.PRO + PRO2_3.PRO + PRO2_4.AXL + PRO2_5.CON + PRO2_6.CON + PRO2_7.STE + PRO2_8.DRI + PRO2_9.SEA + PRO2_10.EPU
Nexus Kit	6	NEX_1.WHE + NEX_2.PRO + NEX_3. PCA + NEX_4.CON + NEX_5.DRI + NEX_6.SEA



3

Check and count bolt & nut bags

You find the bag numbers and names on the bag itself.

Product (Kit)	Quantity of bags	Numbers on bag
Pro Kit 2	13	Base 01, 02, 03, 04 + Plus 05, 06, 07 + Ult 08, 09 + extra bag + PRO 1/3, 2/3, 3/3
Nexus	7	NEX - 01 A, B, C + NEX 02, 03, 04, 05

CHECK YOUR PRINTED MATERIALS

Complete this checklist to ensure printed materials are in order.

<input type="checkbox"/>	Check and count box cards
<input type="checkbox"/>	Check and count assortment box cards

1

Check and count box cards

Find the numbering and naming on each box card.

Product (Kit)	Quantity of Box Cards	Name
Pro Kit 2	10	Box 1 to 10
Nexus Kit	6	Box 1 to 6



2

Check and count assortment box cards

Check numbering on each assortment box card (if more than two).

Product (Kit)	Quantity of Box Cards	Name
Pro Kit 2	1	N/A
Nexus Kit	1	N/A

WHEN FIRST OPENING YOUR EDUCATION KIT

Prepare and organize

- 8 Move and Store Your Kit
- 8 Fill Your Assortment Box
- 9 Sort Your Box Cards
- 10 Use Your Manuals
- 11 Rides You Can Build Twice



MOVE AND STORE YOUR KIT

The grey boxes are designed to be easily stacked for efficient storage. Education Kits include a trolley for safe and easy transport.

- 1 Place the box with the highest number on the trolley first. This is also the tallest box, minimizing the need to bend down.
 - 2 Stack the remaining boxes on top in numerical order, from highest to lowest.
 - 3 Use the trolley to move the stacked boxes safely. Always hold the boxes firmly during transport to prevent them from falling.
- TIP** Place all stickers on the same side of the boxes. This makes it easy to check at a glance if all grey boxes are present.

FILL YOUR ASSORTMENT BOX

Organize your bolts, nuts, and other small parts efficiently by using the Infento assortment box.

- 1 Unpack everything and open the empty assortment box.
- 2 Place the box card in the lid of the assortment box.
- 3 Sort bolts, nuts, and small parts into the compartments as shown on the box card.
- 4 Keep the box closed, with the box card inside, when not in use to prevent losing parts.



Important note:

- **Cleanup:** After building, make sure students return all parts exactly as shown on the box card, so the next group can work easily and teachers can check completeness.
- **Types of assortment boxes:** The Pro Kit 2 comes with a metal assortment box, whereas the Nexus Kit features a plastic version.



SORT YOUR BOX CARDS

All Education Kits come with box cards that show which parts belong in each grey box, including the correct quantities.

- 1** Divide the box cards over the grey boxes and match the numbers with the stickers.

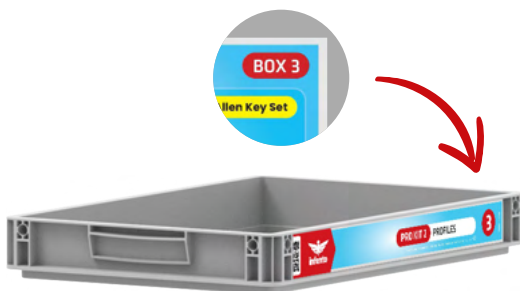

- 2** Check if the quantities on the box cards match the parts in the grey boxes.

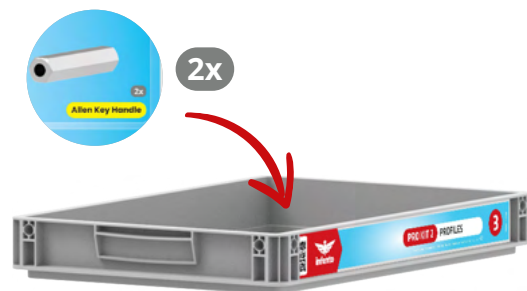

- 3** Place the box card on top of the parts inside the grey boxes so it won't get lost.

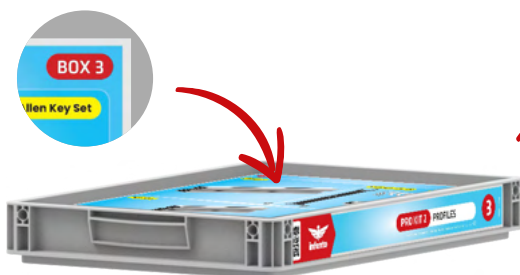

- TIP** Slide the box card between foam and grey box for quick access. After disassembly, return all parts as shown so students can find them and teachers can check completeness.





USE YOUR MANUALS

When you are ready to start building, match the manual with your students' age, skill level, and available lesson time. Choosing the right model ensures a smooth, motivating, and successful building experience.

1 Match age, skill, and time available with the manual and choose a model that fits.

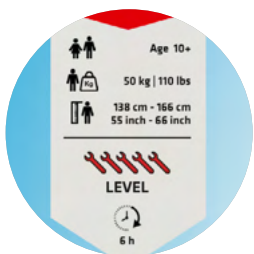

2 Each Ride can be built by **4-8 students**; manuals have different build paths for working in **pairs**.

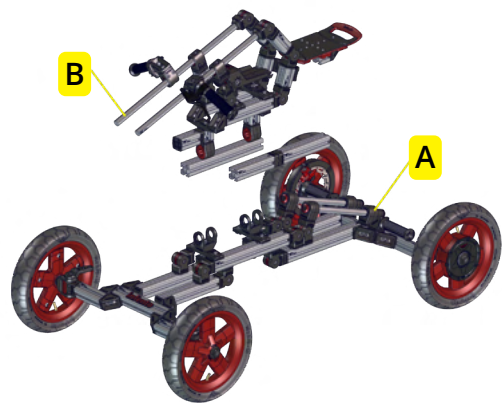

3 All build paths can be completed in **parallel**. Once finished, each duo can combine their built sections to complete the Ride.

TIP Manuals are digitally available at www.infento.com/support

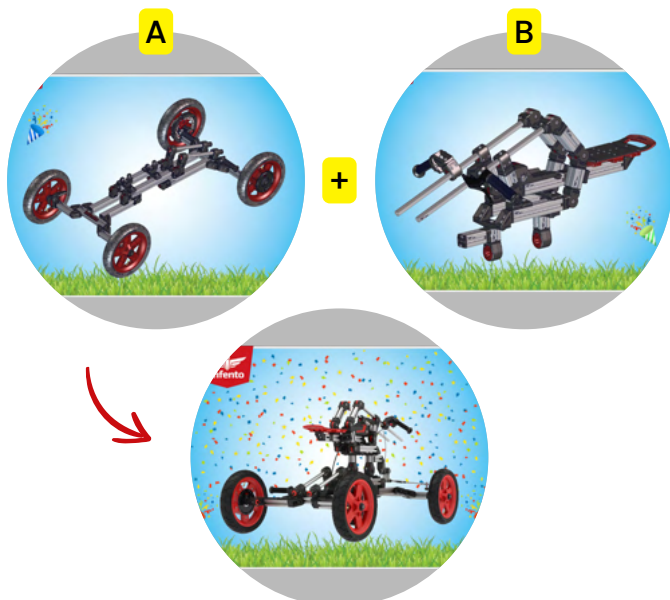



RIDES YOU CAN BUILD TWICE

Education Kits include extra parts. These parts allow you to build some Rides twice using one Kit. This means students can work in groups, build the same Ride, and compare their results. They can also organize challenges or races.

Below is an overview of the **models that can be built twice from one Kit.**

Pro Kit 2	Nexus Kit
Caterpillar	Caterpillar
Caterpillar XL	Caterpillar XL
Flowmotion	Cruiser
Flowmotion XL	Flowmotion
Gecko	Flowmotion XL
Gecko XL	Gecko
Roller	Gecko XL
Wheelbarrowracer	Waveboard
Rocket Launcher	Wheelbarrowracer



BEFORE YOU START YOUR CLASSES

Pre-building instructions

- 13 Inspect and Inflate The Tires
- 13 Prepare The Handlebar With Rubber Grip
- 14 Prepare The Axle Clamp For Use
- 14 Prepare The Brake Lever For The 7 Inch Wheel House
- 15 Prepare The T-joint For Use
- 16 How To Tighten Bolts and Nuts Properly/Safely



INSPECT AND INFLATE THE TIRES

A smooth ride starts with well-inflated tires—make sure they're ready to roll!

- 1 Ensure no part of the inner tube is caught between the tire and rim.
- 2 Do not **exceed 2 bar** when inflating, otherwise you risk blowing the inner tube.
- TIP** Sun exposure increases tire pressure – so avoid long durations in direct sunlight.



PREPARE THE HANDLEBAR WITH RUBBER GRIP

- 1 Slide the handgrip on the handlebar.
- 2 Check for the correct side.
- 3 No need to remove the handgrip again!





PREPARE THE AXLE CLAMP FOR USE

- 1 Screw in bolts, but don't tighten yet.
- 2 Click the Wedge over the bolts.
- 3 No need to take this assembly apart again.



PREPARE THE BRAKE LEVER FOR THE 7 INCH WHEEL HOUSE

- 1 Position the cable clamp, insert the bolt—don't tighten yet.
- 2 Done. You never have to take this assembly apart again.

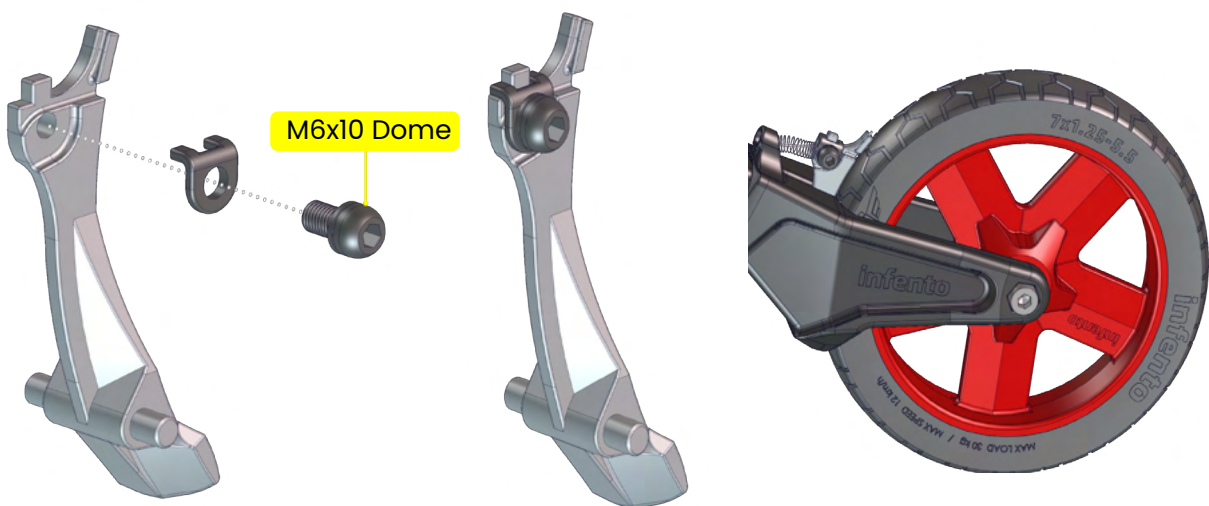



PREPARE THE T-JOINT FOR USE

- 1** Click the metal plate into the T-joint.

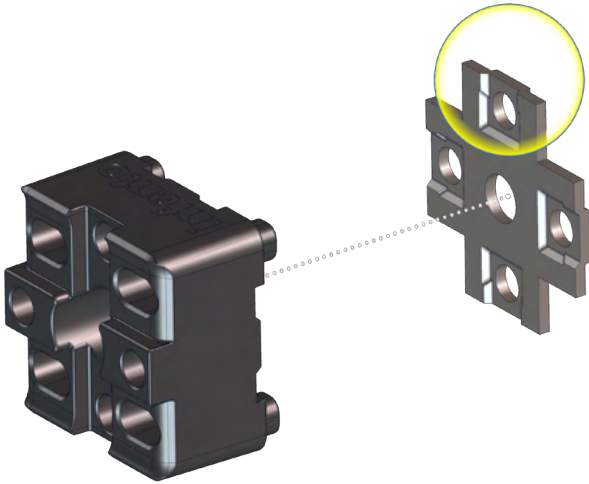

- 2** When it is hard to press the metal plate in, you can use a bolt.

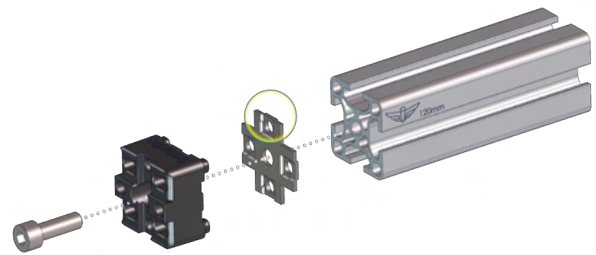

- 3** End result. You never have to take the metal plate off again.

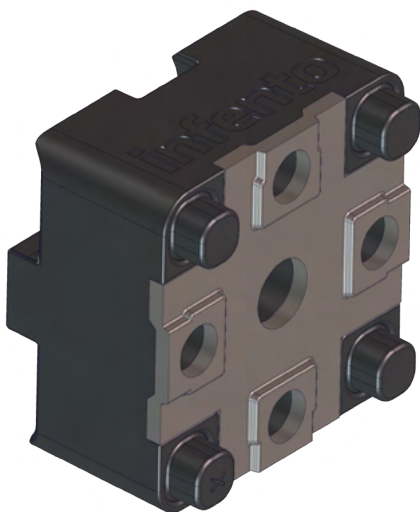

- TIP** How to get the T-joint off the profile Use the 5mm Allen key to prise the T-joint of a profile. The tight fitment is by design to provide for a sturdy connection.

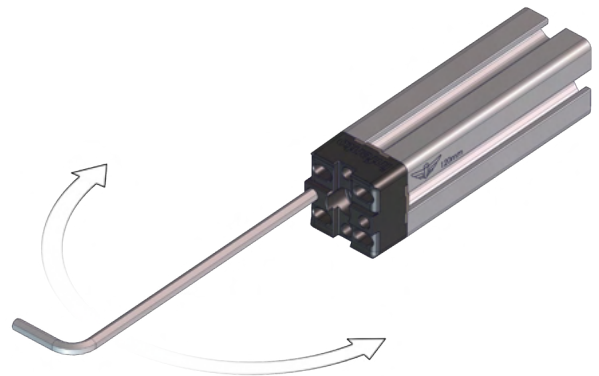



HOW TO TIGHTEN BOLTS AND NUTS PROPERLY/SAFELY

- 1** Use the long end of the Allen key till the bolt almost touches the connector. Bring the connector to the exact position shown in the manual.



- 2** Use the short end of the Allen key to firmly tighten the bolt (15nm).



- TIP** When the connector doesn't allow you use the short end of the Allen key you can use the Allen key handle to firmly tighten the bolt.



- 3** Use the Infento tool to place the connector in the correct position.

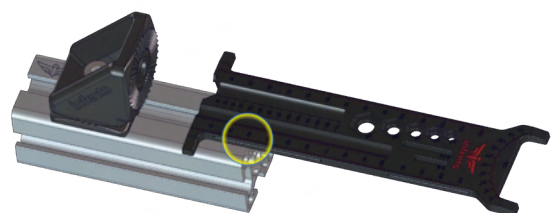
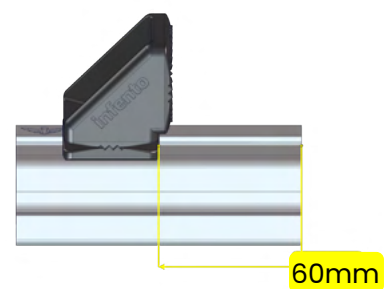

Pre-building instructions



4

Start tightening the bolt and simultaneously visually check that the twistnut indeed twists into locking position.

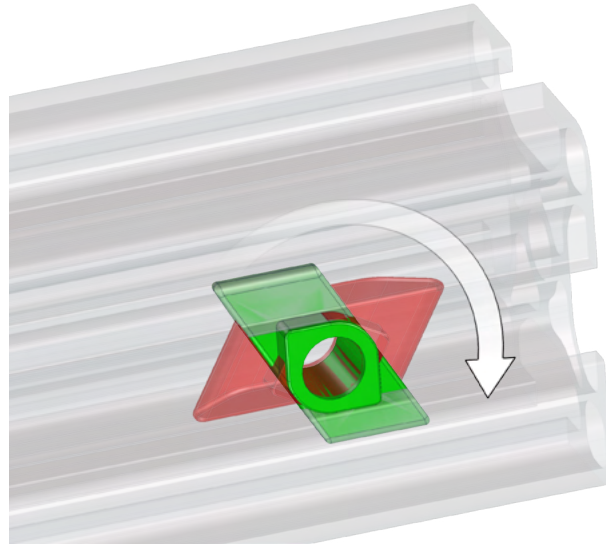

5

Tighten the bolt fully and double check the given distance and placement of the part. Does your result look exactly the same as the image in the manual?

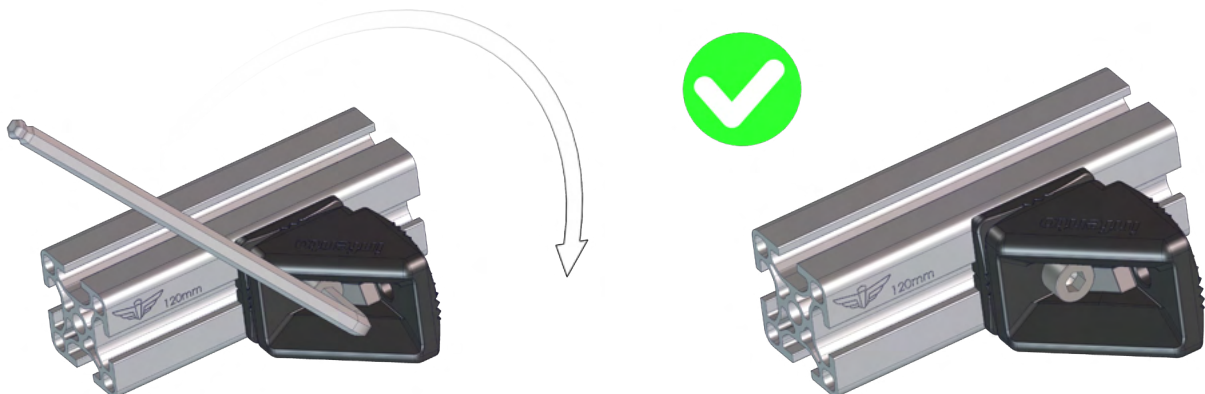

BEFORE YOU INSTALL YOUR EPULSE SYSTEM

ePulse checklist

- 19 Check Your ePulse System & Battery
- 20 Connecting The ePulse System



CHECK YOUR EPULSE SYSTEM & BATTERY

1

Confirm you received all parts

Ensure your ePulse HUB system has these components:

1x HUB motor
1x ePulse docking station
1x Input cable (throttle + e-brake)
1x Set of 2 keys
1x 24V battery (Ultimate: 4.0Ah or Volt: 2.5Ah)ww
1x 2A Charger
1x USB-C connection cable
4x Cable spools (for organizing your cable)
4x Twist nuts + 4x M8x12 bolts (for attaching the cable spools)
1x Velcro Infento band (for securing the cable)

2

Charge your battery

Batteries arrive partially charged. Fully charge them before use.

4.0Ah battery: ~2 hours charging time.
2.5Ah battery: ~1 hour 15 minutes charging time.

3

Review ePulse parts and features

Docking station

- Houses the electronics and software for the system.
- Holds the battery, which slides in securely.

Hub motor power switch (with LED Backlight)

- A tactile, non-latching switch with multiple functions (see page 16 for details).

Key switch for speed settings

- **Position 1:** 6 km/h (default).
- **Position 2:** 11 km/h.
- **Position 3:** Locked at 11 km/h (unlock for 16 km/h—see page 18)

Important: Adults should retain the key for safety and never leave it in the switch while driving, as it may fall out.



4

Infento Logo Push Button

- Located on top of the docking station.
- Press once to release and slide out the battery.

5

Test your ePulse system

Follow these steps to confirm your ePulse system is functioning:



Scan the QR code or [click here](#) to learn more

CONNECTING THE EPULSE SYSTEM

CONNECT THE CABLES FROM THE DOCKING STATION TO THE MOTOR

1

Locate the connectors

- Find the **female connector** on the motor cable.
- Locate the **male connector** on the docking station (below the power switch).

2

Align the connectors

- Look for the **Infento logo** on the flattened surfaces of the female connector.
- Align these with the corresponding surfaces on the male connector.

3

Check the pin alignment

- Make sure the **thick pins** on the male connector match the receiving slots on the female connector.
- If they don't align, rotate one connector **180 degrees**.

4

Connect the plugs

- Once aligned, press the connectors together until you hear a click.
- Use the small notch on the connectors as a guide.



CONNECT THE INPUT CABLE (THROTTLE + EBRAKE) TO THE DOCKING STATION

1

Locate the connectors

- Identify the **male connector** on the end of your input cable.
- Find the **female connector** on the docking station, located below the key switch.

2

Align the connectors

- Look for the **Infento logo** on the two flattened surfaces of the male connector.
- Align these with the corresponding flattened surfaces on the female connector.

3

Check the notch alignment

- Ensure the **thick notch** on the male connector lines up with the receiving notch on the female connector.
- If not aligned, rotate one of the connectors **180 degrees**.

4

Connect the plugs

- Slightly turn the **bayonet clockwise** and gently push the connectors together.
- If aligned correctly, the connectors will slide together smoothly.

5

Lock the connection

- Continue turning the bayonet until it is fully locked in place.

CONNECT BATTERY TO DOCKING STATION

1

Slide the battery into the docking station until you hear a click.

The first time (only the first time), you have to wait 30-40 seconds to let the system initialize and startup. Simply do not touch it for a minute, and everything will be fine. You will see all colors lighting up on your power switch (WHITE RED GREEN BLUE).

2

If you see the colors lighting up, everything is working!

**You're done! Your ePulse system is set up
and ready to go. Enjoy the ride!**

SET-UP AND INSTRUCTION GUIDE

ePulse instructions

- 23 Battery Safety Precautions
- 23 Power Switch Functions
- 24 Wheel Calibration: Why and How
- 25 Key Switch Functions / Speed Selection
- 26 Unlocking Speed Mode 3 (16 km/h - 10 mph)
- 27 Dual Drive Installation Instructions
- 28 Drive Time Estimates for Your Infento Ride
- 29 Colors/Error Codes and What They Mean
- 31 Need Help?



BATTERY SAFETY PRECAUTIONS

- Ensure that the DC connector on the battery remains dry at all times.
- Do not place any conductive objects, such as metal, aluminum, copper, or other metallic materials, near or into the DC connector on the battery.

The battery is designed with a built-in safety feature – a fuse – that helps prevent potential damage from short circuits. If the battery detects a safety issue due to improper handling, the fuse will automatically disconnect, preventing the battery from accepting a charge.

Important note

- **Disconnected fuse:** Once this safety feature is activated, the fuse cannot be reset and will need to be repaired or replaced.

POWER SWITCH FUNCTIONS

The power switch on your ePulse system allows you to manage various operations. Use the table below to understand its functions and how to operate it effectively.

Powerswitch button press	Active system state	Dependency	Function
Press 1x + press brake handle within 20s	OFF	Press brake handle 1x within 20s	Turns the system ON
Press 1x	ON	None	Turns the system OFF
Press 3x	OFF	None	Activates wheel calibration (see next step)
Press 5x	OFF	None	Inverts rotation direction for reverse mode
Long press (3 seconds)	OFF	None	Resets system errors



Scan the QR code or [click here](#) to learn more



WHEEL CALIBRATION: WHY AND HOW

WHY CALIBRATE YOUR WHEEL?

Calibration ensures your ePulse system detects the correct wheel size for **accurate speed, smooth performance, and safe riding**. Without calibration, your ride may not function correctly and it will go slower.

Calibration is only needed for the 10-inch wheel and takes less than 10 seconds. The 14-inch wheel is automatically detected by the engine.

HOW TO CALIBRATE YOUR WHEEL

1

Lift the wheel

- Raise the motorized wheel off the ground so it can spin freely.

2

Activate calibration mode

- Ensure the system is **OFF**.
- Press the **power switch** 3 times.
- The LED will turn **purple**, signaling calibration mode.

3

Let the system calibrate

- Spin the wheel freely to allow the system to detect its size.
- The LED will indicate the result:
 - **BLUE LED:** Small wheel detected (10-inch).
 - **WHITE LED:** Large wheel detected (14-inch).
 - **RED LED:** Calibration failed (retry required).

4

If calibration fails

- The system will automatically try a second calibration.
- If it fails again;
 1. Reset the error by holding the power switch for 3 seconds
 2. Repeat the calibration steps.



Scan the QR code or [click here](#) to learn more

Important notes

- **Battery Reset:** Removing the battery resets calibration. Recalibrate after reinserting the battery if using a 10-inch wheel.
- **No Calibration Needed for Large Wheels:** The system automatically detects 14-inch wheels without calibration.



KEY SWITCH FUNCTIONS / SPEED SELECTION

The key switch allows you to select the speed mode for your ride, depending on the wheel size and calibration.

SPEEDS WITH LARGE WHEEL (CALIBRATION NOT NEEDED)

Key Position	Speed (km/h)	Speed (mph)	Calibration required?
Position 1	6	3.7	Not needed (same speed)
Position 2	11	6.8	Not needed (same speed)
Position 3 (Locked)	11	6.8	Not needed (same speed)
Position 3 (Unlocked)	16	10	Not needed (same speed)

SPEEDS WITH SMALL WHEEL (AFTER CALIBRATION)

Key Position	Speed (km/h)	Speed (mph)	If not calibrated
Position 1	6	3.7	4 km/h (2.5 mph)
Position 2	11	6.8	7 km/h (4.3 mph)
Position 3 (Locked)	11	6.8	7 km/h (4.3 mph)
Position 3 (Unlocked)*	16	10	11 km/h (6.8 mph)

*Read the next page to learn how to unlock Speed Mode 3!



Scan the QR code or
[click here](#) to learn more

Important note

- **Experiencing low speed:** Check whether the speed is the same in all three key positions. If it is, the motor is likely set to reverse. To correct this, refer to the Power Switch Functions section (Page 16) for instructions on inverting the rotation.



UNLOCKING SPEED MODE 3 (16 KM/H - 10 MPH)

Unlocking Speed Mode 3

Every Infento ride comes with two default speed settings:

- **Position 1:** 6 km/h
- **Position 2 and 3 (default):** 11 km/h

For advanced/older riders, there is an option to unlock **Position 3** and enable a top speed of **16 km/h (10 mph)**!

Before unlocking this speed mode, carefully assess the following:

1

Your Child's Abilities

- Ensure your child has the skill and maturity to handle higher speeds.

2

Ride Quality and Safety

- Verify that the ride has been built correctly following the Infento manual.
- Ensure there are no loose parts and that the brake functions properly.



Scan the QR code or [click here](#) to learn more

Important note

- **Parental responsibility:** Unlocking Speed Mode 3 increases the ride's speed, so extra caution is needed. As a parent, you are responsible for ensuring the safe use of the ride.

To proceed with unlocking, you will be required to agree to terms of use through a short form on our website. This is to confirm your understanding of the responsibilities and precautions involved.

With safety as our priority, Speed Mode 3 can offer an exciting experience when used responsibly!

If you feel confident in both your child's abilities and the ride's safety, visit the manuals page on My Infento to learn how to unlock Speed Mode 3.



DUAL DRIVE INSTALLATION INSTRUCTIONS

1

Install the ePulse Hub Motors

- Install the **first Hub Motor** together with the throttle/brake and the first docking station (referred to as the *main docking*) according to the manual.
- Install the **second Hub Motor** on the wheel of your choice.

2

Install the second docking station

- **Place the second docking station** (referred to as the *secondary docking*) close to the main docking.
- Maximum distance depends on the **USB-C cable length**.
- **Note:** No throttle/brake cable is connected to the secondary docking.

3

Connect the docking stations

- Plug the **USB-C cable** between the main and secondary docking.
- Set both dockings to the **same speed setting** (1-2-3).
- Insert the batteries into both docking stations at the **same time**.

4

Check Hub Motor direction

- Inspect the position of the secondary hub motor:
 - If **aligned** with the first motor, then skip step 5.
 - If **opposite** the first motor, then follow step 5.
- **Tip:** If wheels spin in opposite directions when throttling, then follow step 5 as well.

5

Reverse drive direction (if needed)

- Disconnect the **USB-C cable** from the secondary docking.
- With the secondary docking **off**, press its button **5 times** to reverse direction.
- A **purple light** confirms the change.
- With both dockings **off**, reconnect the USB-C cable.

6

Power on the system

- Turn on the **main docking** and press the brake.
- The secondary docking will turn on automatically.
- Your Dual Drive is now ready!

Troubleshooting

- **Flashing blue or blue-white light:**
 - Remove both batteries, wait a few seconds, then reinsert them.
 - This resets the error.
- **After disconnecting the USB-C cable:**
 - Hold the power button for **3 seconds** or remove the battery briefly to reset.



DRIVE TIME ESTIMATES FOR YOUR INFENTO RIDE

Curious how long your ride will last? The table below provides estimated drive times based on rider weight, battery size, and wheel type. These estimates consider real-world conditions like small inclines, turns, and variable speeds to give you a practical idea of what to expect.

The **4.0 Ah battery** is included in the **Ultimate Kit**, and the **2.5 Ah battery** comes with the **Volt Kit**. Soon, these batteries will be available for purchase in the **Spare Parts** section of our webshop.

CHILD (40 KG)

Battery	Wheel	Drive Time
4.0 Ah	Large wheel	30–60 minutes
4.0 Ah	Small wheel	40–60 minutes
2.5 Ah	Large wheel	20–40 minutes
2.5 Ah	Small wheel	20–40 minutes

CHILD/ADULT (80 KG)

Battery	Wheel	Drive Time
4.0 Ah	Large wheel	25–45 minutes
4.0 Ah	Small wheel	25–45 minutes
2.5 Ah	Large wheel	15–30 minutes
2.5 Ah	Small wheel	20–35 minutes

KEY NOTES ON DRIVE TIME

Driver behavior: Frequent acceleration and braking reduce drive time compared to maintaining steady speeds.

Speed settings impact

- **Lower Speeds (Position 1):** Upper range of drive time.
- **Higher Speeds (Position 3):** Lower range of drive time.



COLORS/ERROR CODES AND WHAT THEY MEAN

Understanding error codes is essential to ensure the smooth operation of your Infento ride. The ePulse system uses LED lights to indicate the current status or errors that may occur. Below, you'll find a guide to the different error codes, what they mean, and the steps you can take to resolve them.

If an error persists, stop driving and contact support@infento.com with a description of the issue and the error code.

ERROR CODES GUIDE

GREEN (ALL OK)				
Component	Error	Code	E-Code	Action
All	No errors	Solid Green	G	System is functioning normally
State	Stall error	Light turns green, then goes off, and after a short pause blinks green one time	G1	Motor stalled for more than two seconds; longpress (3 sec), and drive.

RED (BATTERY ERRORS)				
Component	Error	Code	E-Code	Action
Battery	Battery low	Solid Red	R	Drive home and charge your battery
Battery	Battery empty	Light turns red, then goes off, and after a short pause blinks red one time	R1	Charge your battery



BLUE (CONTROLLER AND MOTOR ERRORS)				
Component	Error	Code	E-Code	Action
Controller	Initialization error	Light turns blue, then goes off, and after a short pause blinks blue one time	B1	Long press (3 sec) and drive. If it persists, contact support
Controller	Connection error	Light turns blue, then goes off, and after a short pause blinks blue two times	B2	Check motor connection and pins
Controller	Frontend error	Light turns blue, then goes off, and after a short pause blinks blue three times	B3	Contact support Do not drive
Controller	Voltage peak detected	Light turns blue, then goes off, and after a short pause blinks blue four times	B4	Long press (3 sec) and retry. If it recurs, wait 30 min to charge and contact support.
Controller	Board temp error	Light turns blue, then goes off, and after a short pause blinks blue five times	B5	Long press (3 sec), wait 10 min, and retry. Monitor for overheating
Motor	Encoder error	Light turns blue, then goes off, and after a short pause blinks blue six times	B6	Contact support. Do not drive
Motor	Motor temp error	Light turns blue, then goes off, and after a short pause blinks blue seven times	B7	Long press (3 sec), wait 10 min, and retry. Monitor for overheating.



WHITE (SPECIFIC COMPONENT ERRORS)				
Component	Error	Code	E-Code	Action
eBrake	Check eBrake	Solid White	W	Check brake disconnect function and ensure proper operation.
Throttle 1	Throttle error	Light turns white, then goes off. After a short pause, it blinks white once	W1	Check throttle connection and pins. Contact support if unresolved.
Throttle 2	Not in use	Light turns white, then goes off, and after a short pause blinks white two times	W2	Currently not used.
Key Switch	speed selection error	Light turns white, then goes off, and after a short pause blinks white three times	W3	Ensure key switch position is correct and restart the system.
USB Connection	Dual motor error	Light turns white, then goes off, and after a short pause blinks white four times	W4	Check USB-C connection. If unresolved, contact support.

NEED HELP?

If an error keeps occurring:

1. Stop driving immediately.
2. Contact **support@infento.com** with a description of the issue, your order number and the E-code.

Stay safe and enjoy your Infento Ride!

ESSENTIAL TIPS TO GET STARTED

Building Tips

- 33 How To Detach The T-Joint From Profiles
- 33 How to Tell the Difference between Driven vs. Free-Spinning Wheels
- 34 How To Use The Angle Joint
- 34 How To Measure Angles
- 35 3 Ways To Secure A Connector To A Profile Or Another Connector
- 40 How To Use The Infento Measurement Tool
- 43 Before You Ride: Safety Checks



HOW TO DETACH THE T-JOINT FROM PROFILES

Use the 5mm Allen key to pry the T-joint of a profile.
The tight fitment is by design to provide for a sturdy connection.

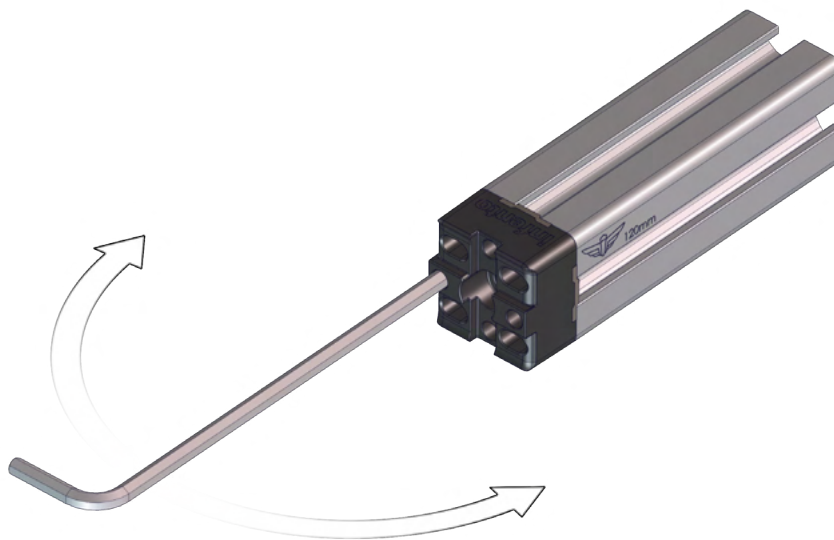

HOW TO TELL THE DIFFERENCE BETWEEN DRIVEN VS. FREE-SPINNING WHEELS

There are two options in wheel hubs: driven and free spinning. You can recognize them by looking at the centre; the driven hub has a locked centre, and the free spinning hub has bearings so the centre can spin.

Driven wheel

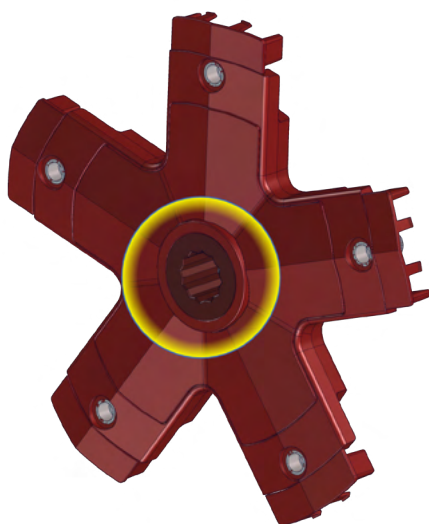

Free spinning wheel

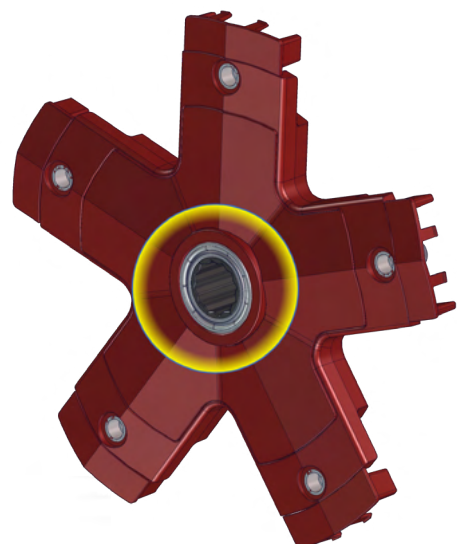



HOW TO USE THE ANGLE JOINT

1 Find the angle in the manual.

2 You set the correct angle using the markings.

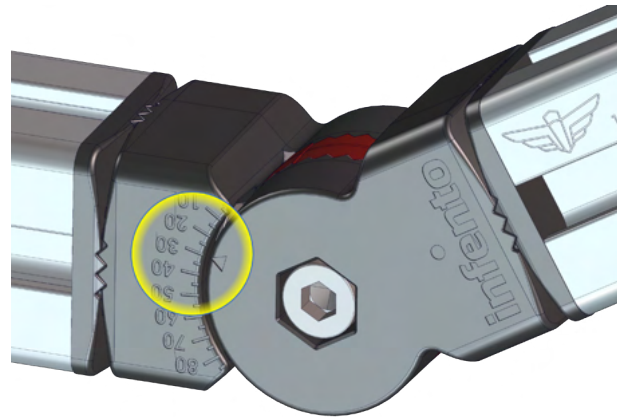
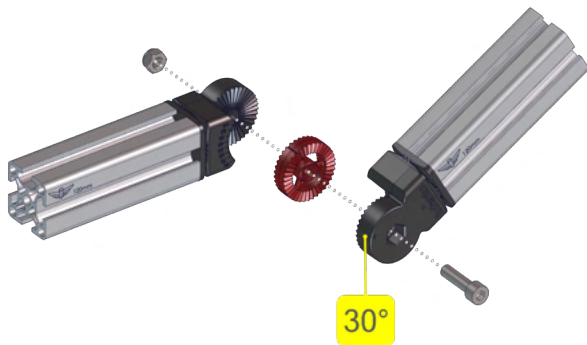

HOW TO USE MEASURE ANGLES

1 Find the angle in the manual

2 Use the Infento tool to place connector in the correct angle

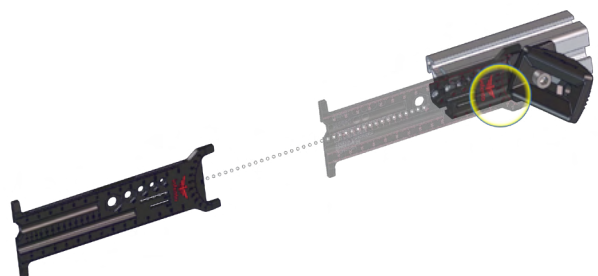
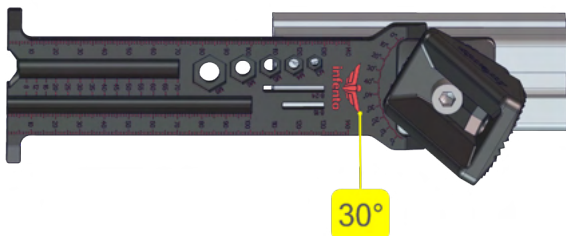



3 WAYS TO SECURE A CONNECTOR TO A PROFILE OR ANOTHER CONNECTOR

There are three ways to secure a connector to a profile or another connector. Below are the three methods, and the following pages will show step by step instructions how to connect them.

1

Attaching a connector to the the **end** of a profile.

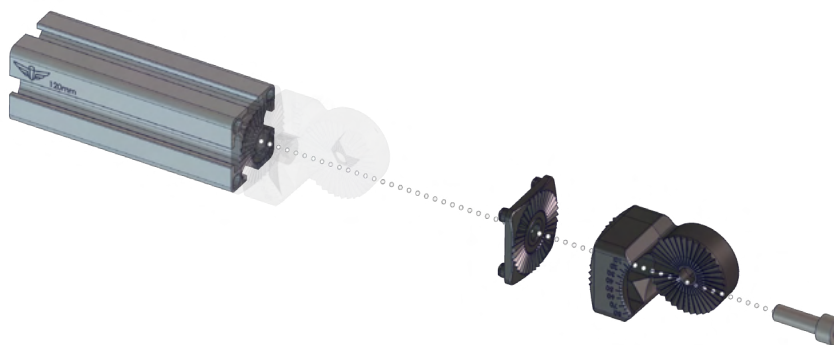

2

Attaching a connector to the **side** of a profile.

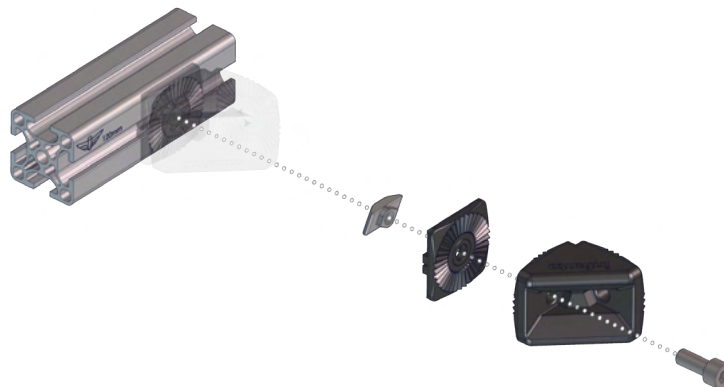

3

Attaching two connectors together.

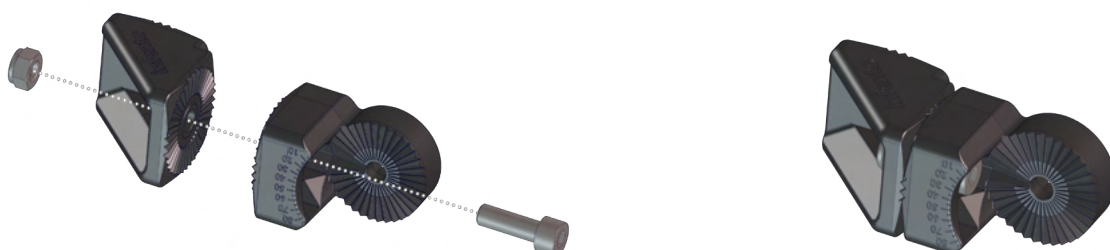



STEPS TO SECURE A CONNECTOR ON THE END OF A PROFILE

- 1 Get all the parts shown in the building step. Do not assemble yet.

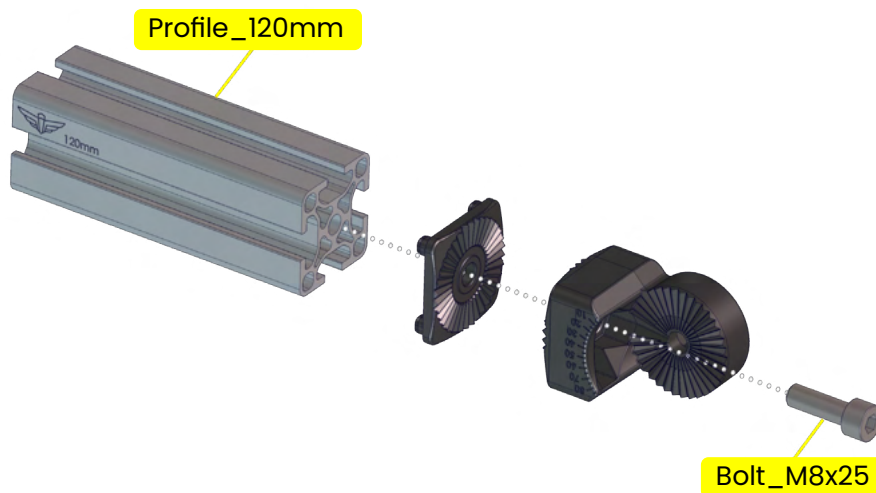

- 2 Press the base plate end onto the profile. Especially the first time this needs some strength. This by design to take away movement between parts.

TIP You can also let the bolt press in the base plate end when you tighten the bolt.





- 3** Now firmly tighten the bolt.

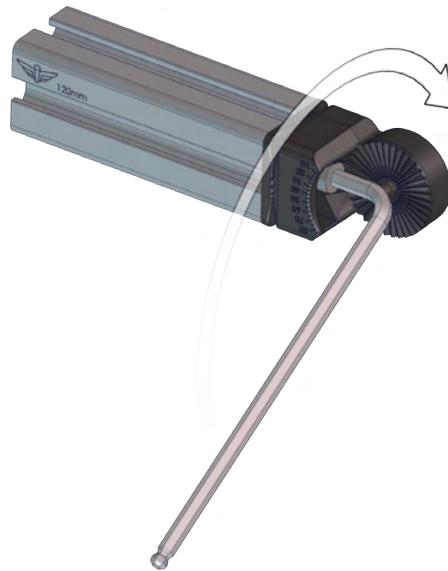

TIP When there isn't a distance specified in the manual, the connector must align with the end of the profile.

Example instruction

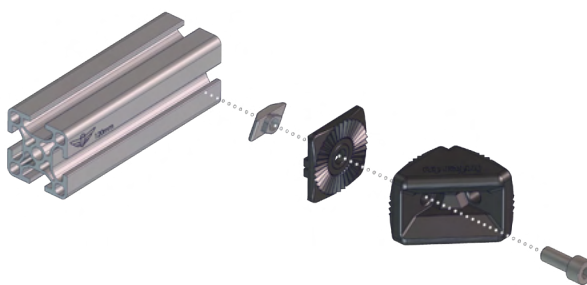

End result





STEPS TO SECURE A CONNECTOR ON THE SIDE OF A PROFILE

- 1 Get all the parts shown in the building step. Do not assemble yet.

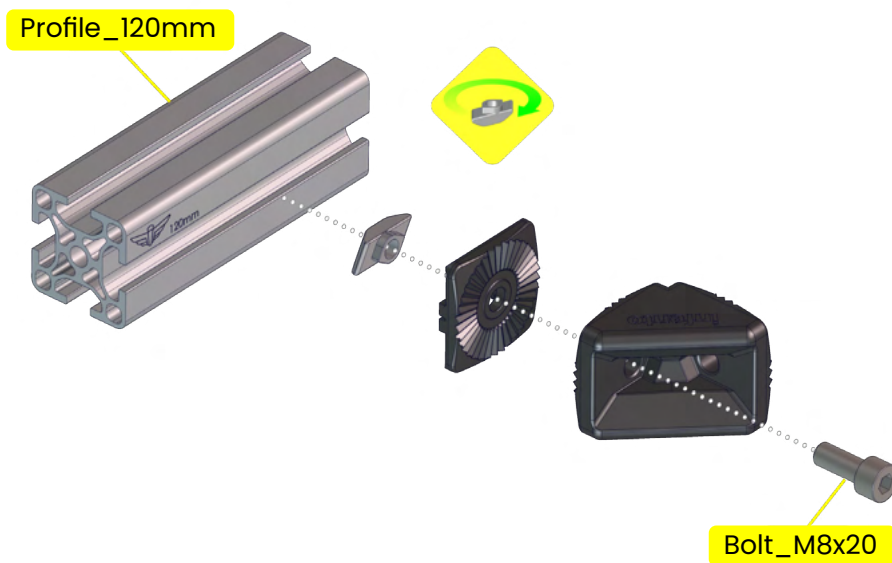

- 2 Pre-assemble everything together. Nut, plate, connector and bolt.

TIP Fix the twistnut on the bolt with 1 turn. Always align the twist with the ridges on the side.

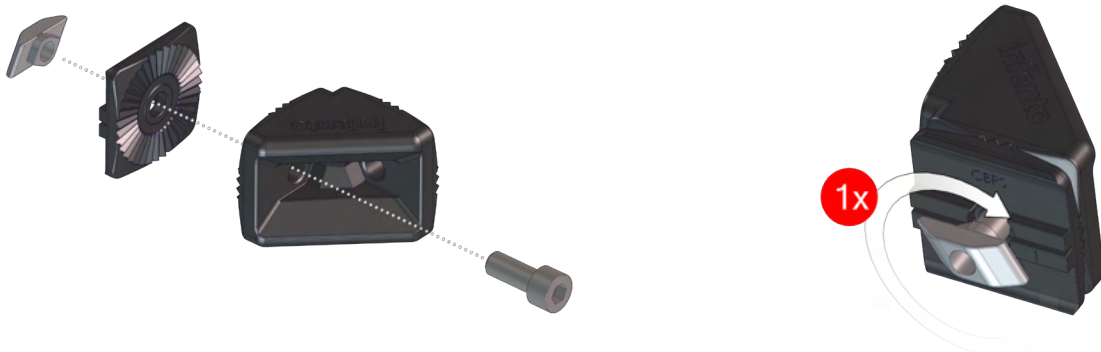



3

Place the pre-assembly in the given spot.
IMPORTANT: Visually check the twistnut did twist into position.

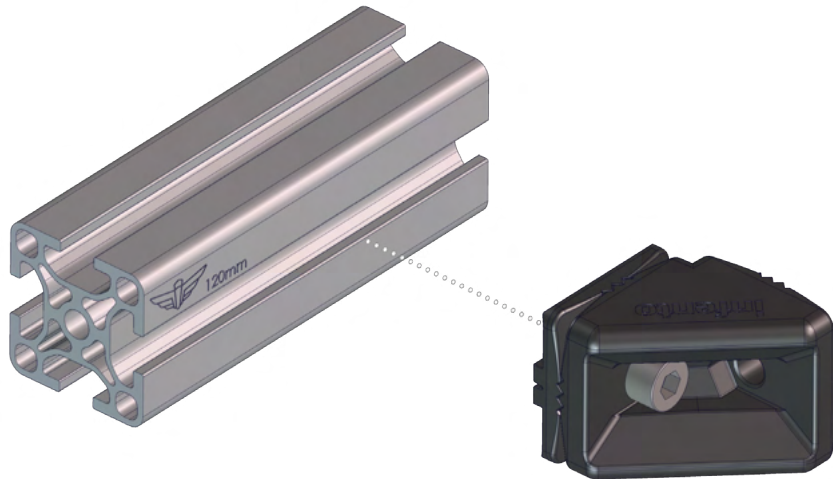

STEPS TO SECURE A CONNECTOR TO ANOTHER CONNECTOR

1

Get all the parts shown in the building step. Assemble the nut, two connectors, and the bolt in the desired orientation.

2

Then firmly tighten the bolt using an Allen key.

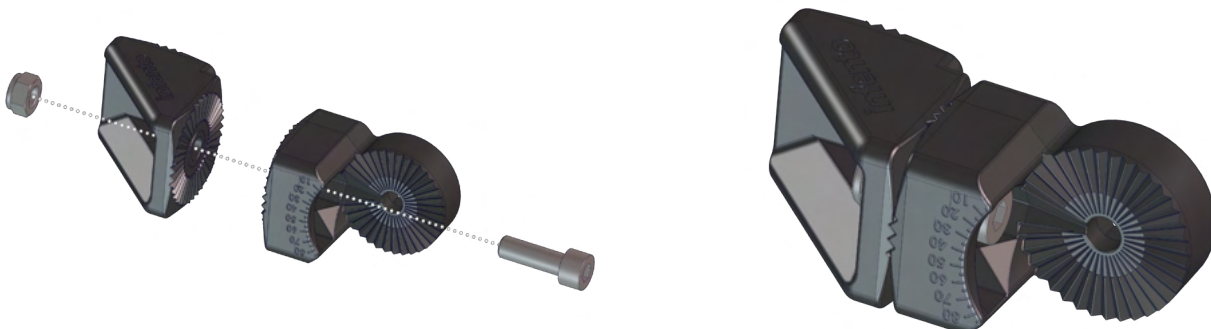



HOW TO USE THE INFENTO MEASUREMENT TOOL

CHECKING SIZES OF FASTENERS

Length countersunk bolts

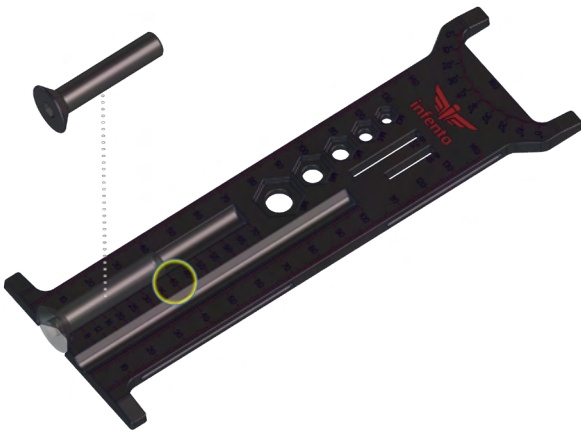

Length standard bolts



Size all bolts



Nuts





Size washers

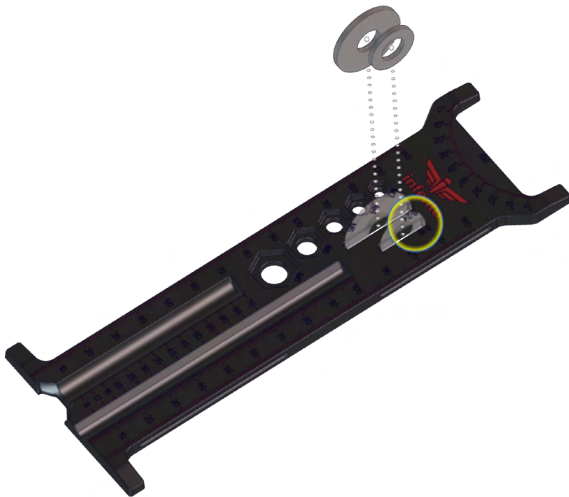

MEASUREMENT DISTANCES AND ANGLES

1 Find the distance in the manual.

2 Find the distance in the manual.

Use the left side for measuring distances

Use this side to measure angles

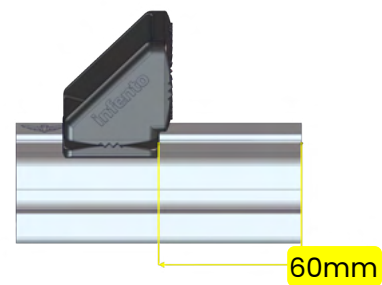
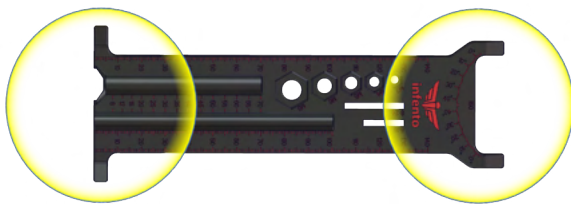

3 Use the Infento tool to place the connector in the correct position.

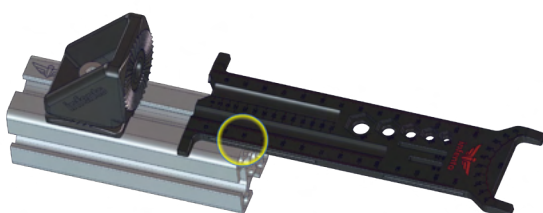



BEFORE YOU RIDE: SAFETY CHECKS

WHAT TO DO

Wear a helmet and protective gear if possible.
Ensure no loose clothing or strings are near the wheels.
Inspect the ride for loose bolts or parts before each use.
Check the brakes and steering system before each ride.
Teach children how to safely operate the ride before use.
Store the ride indoors in a dry place when not in use.
Regularly clean the wheels and moving parts to ensure smooth operation.
Charge the ePulse battery only with the provided charger and in a safe, dry location.

WHAT TO AVOID

Don't allow young children to use the ride unsupervised or without proper instruction.
Don't ride without securing all fasteners and ensuring proper assembly.
Don't ignore unusual noises or jerky movements while using the ride.
Don't allow multiple riders if the model is designed for only one person.
Don't use the ride on steep hills or unsafe terrains.
Don't overcharge the battery by leaving it plugged in for too long.
Don't leave the ride with the ePulse engine outside in the rain.

