



Age 8 - 14



69 kg | 153 lbs



118 cm - 166 cm  
37 inch - 66 inch



LEVEL



5.5 h



# QUAD ATV<sup>G1</sup>







Profile\_80mm

Bolt\_M8x25

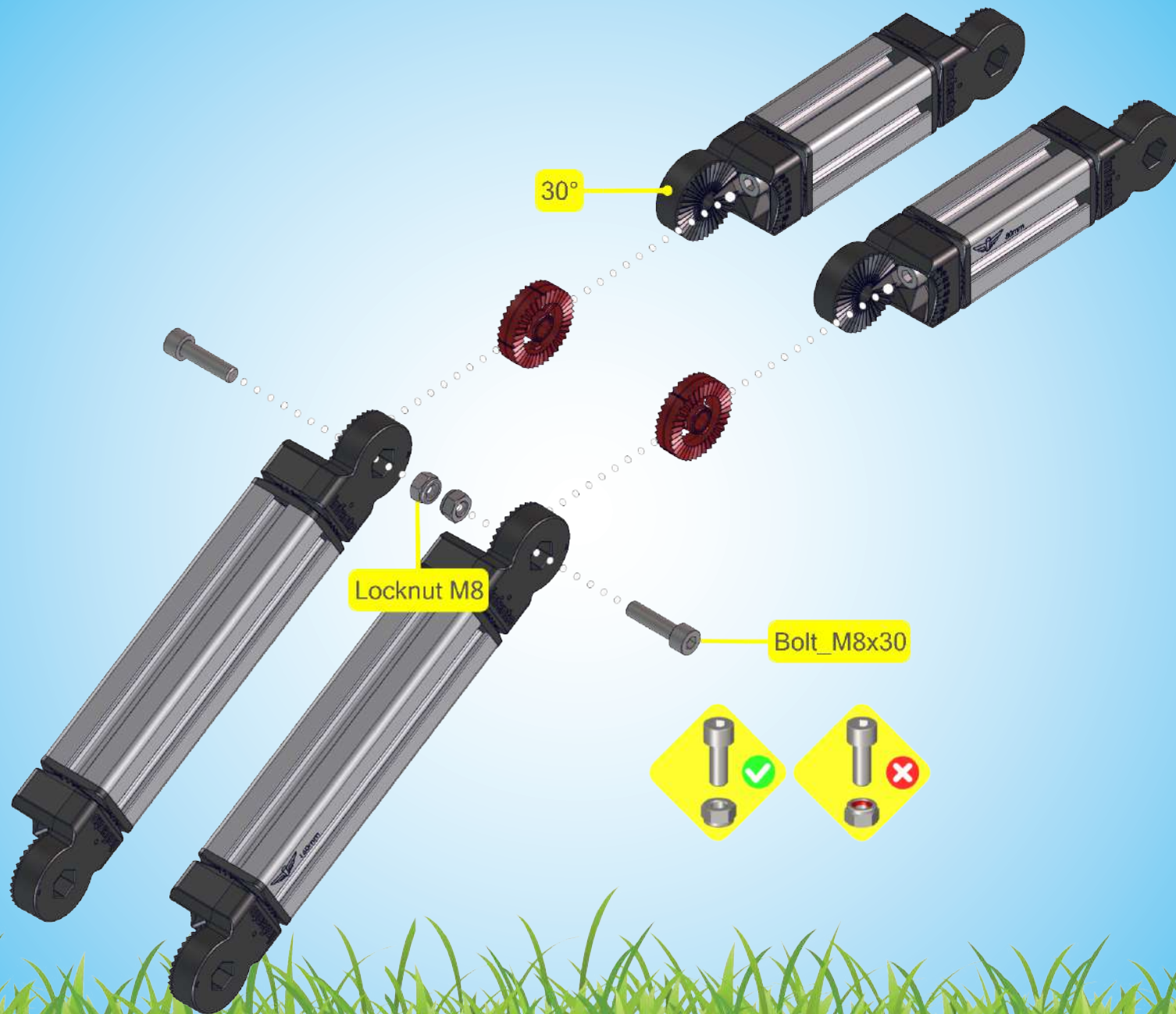



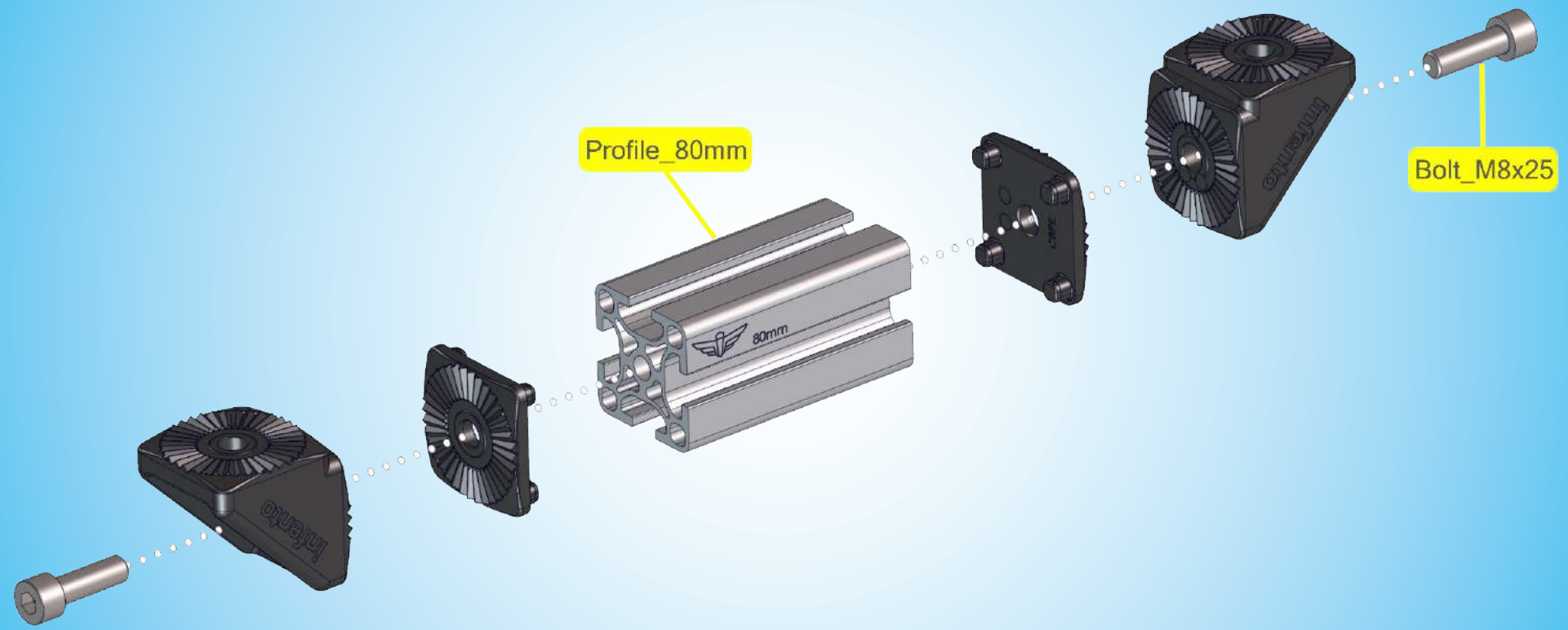

Bolt\_M8x25

Profile\_80mm

B.2

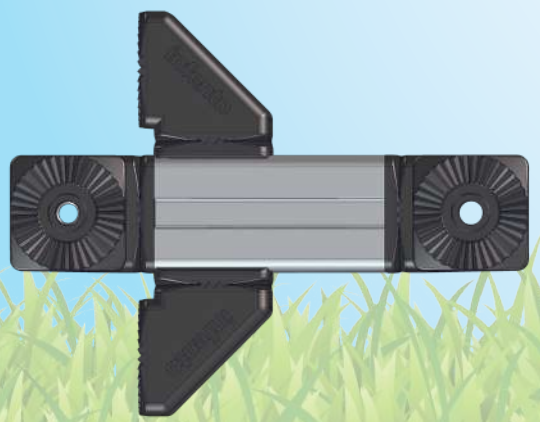



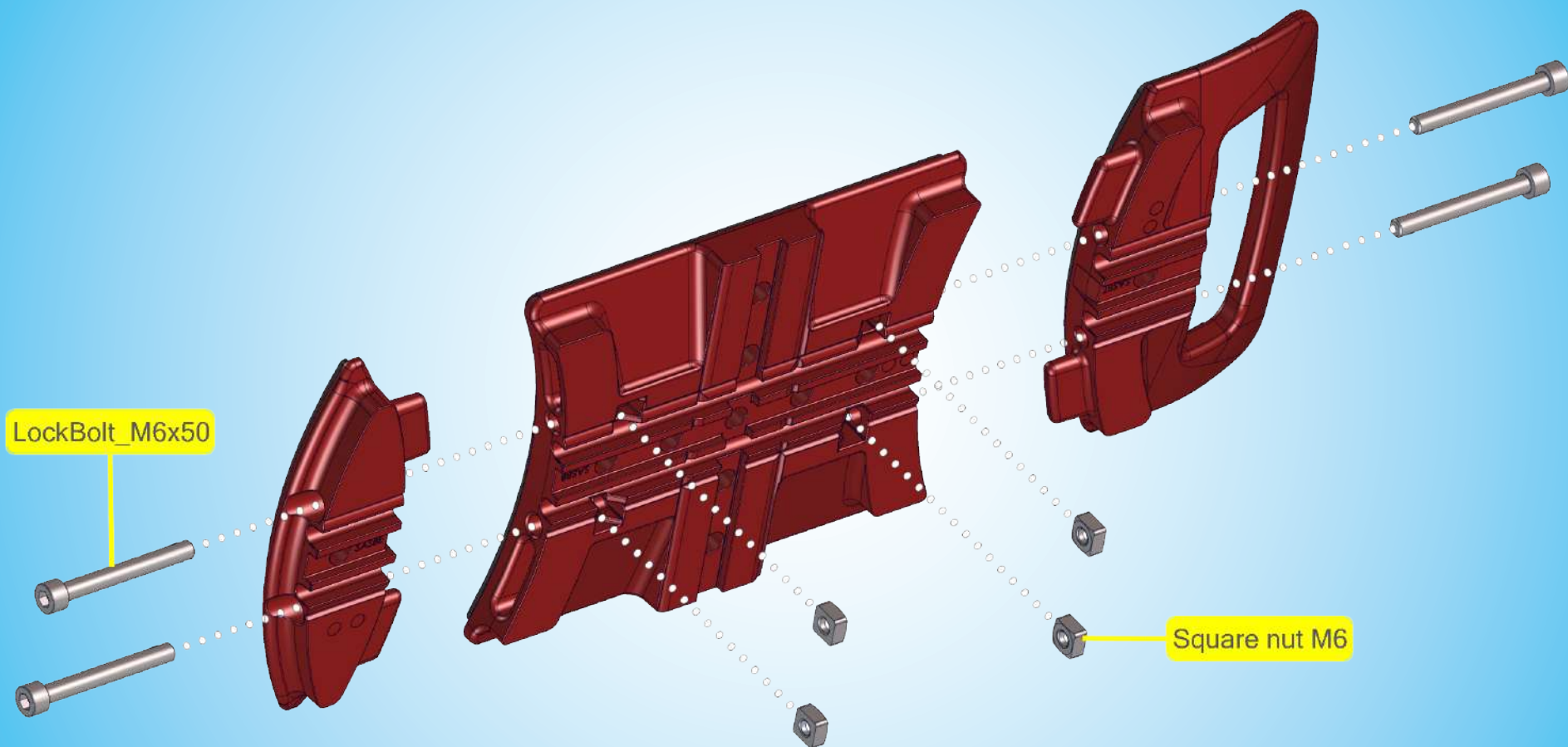

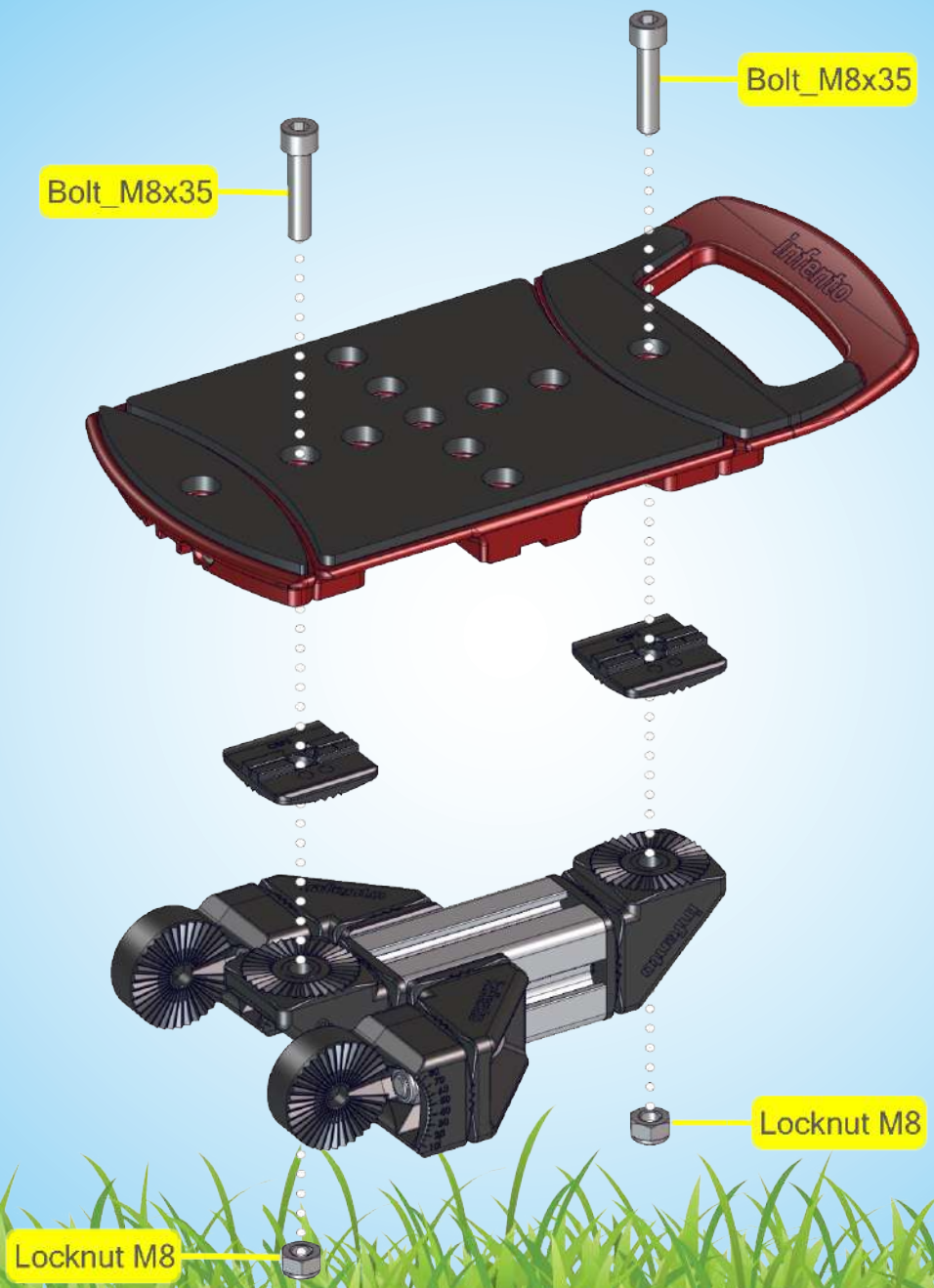

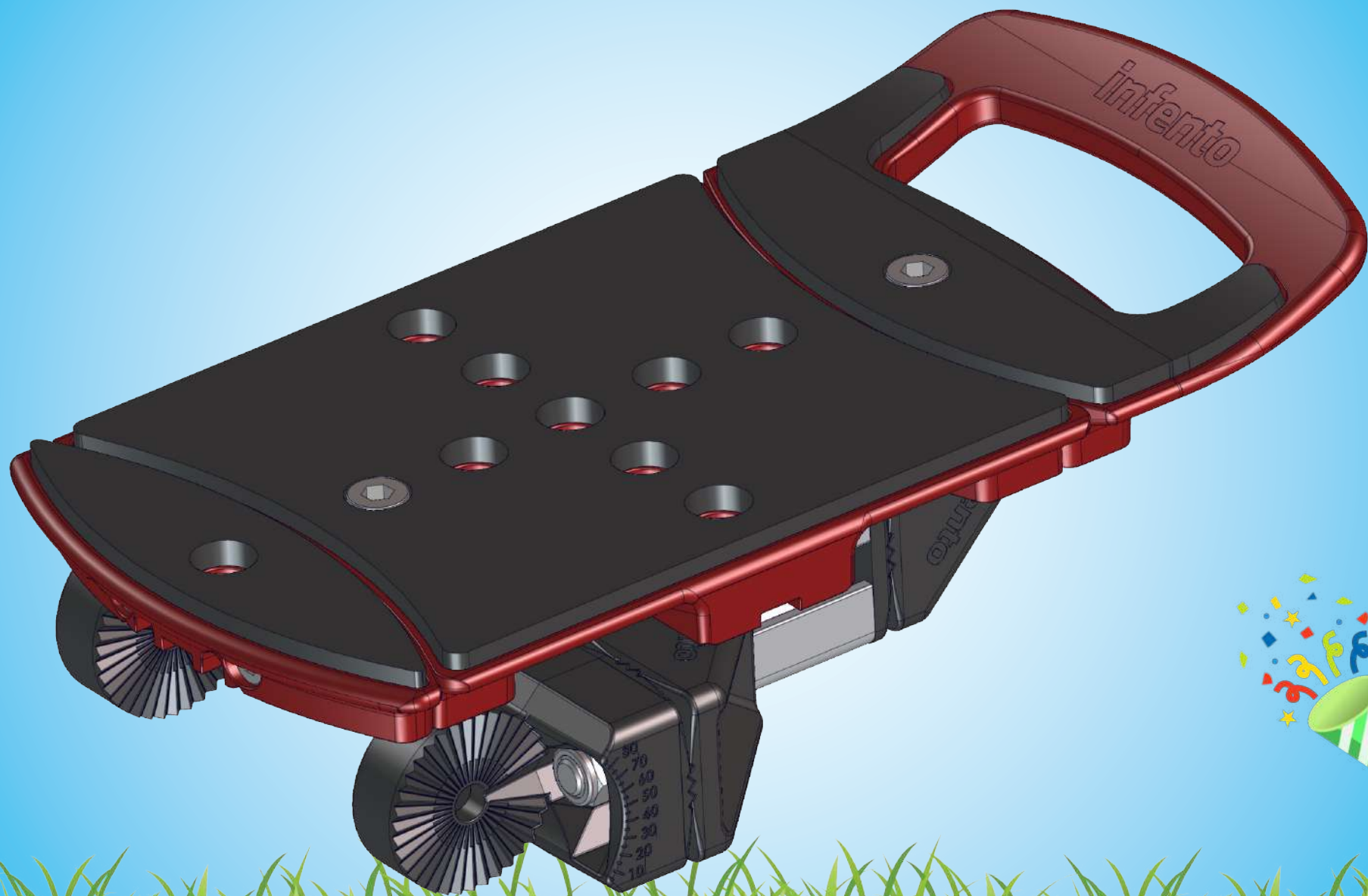



Bolt\_M8x25

Profile\_320mm

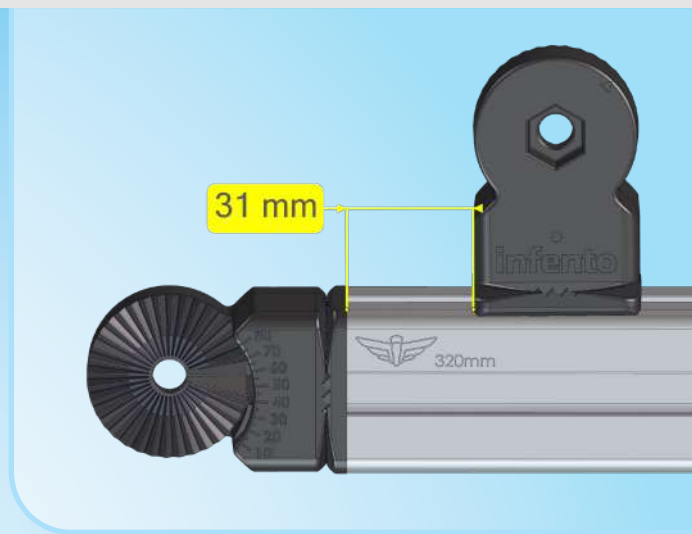

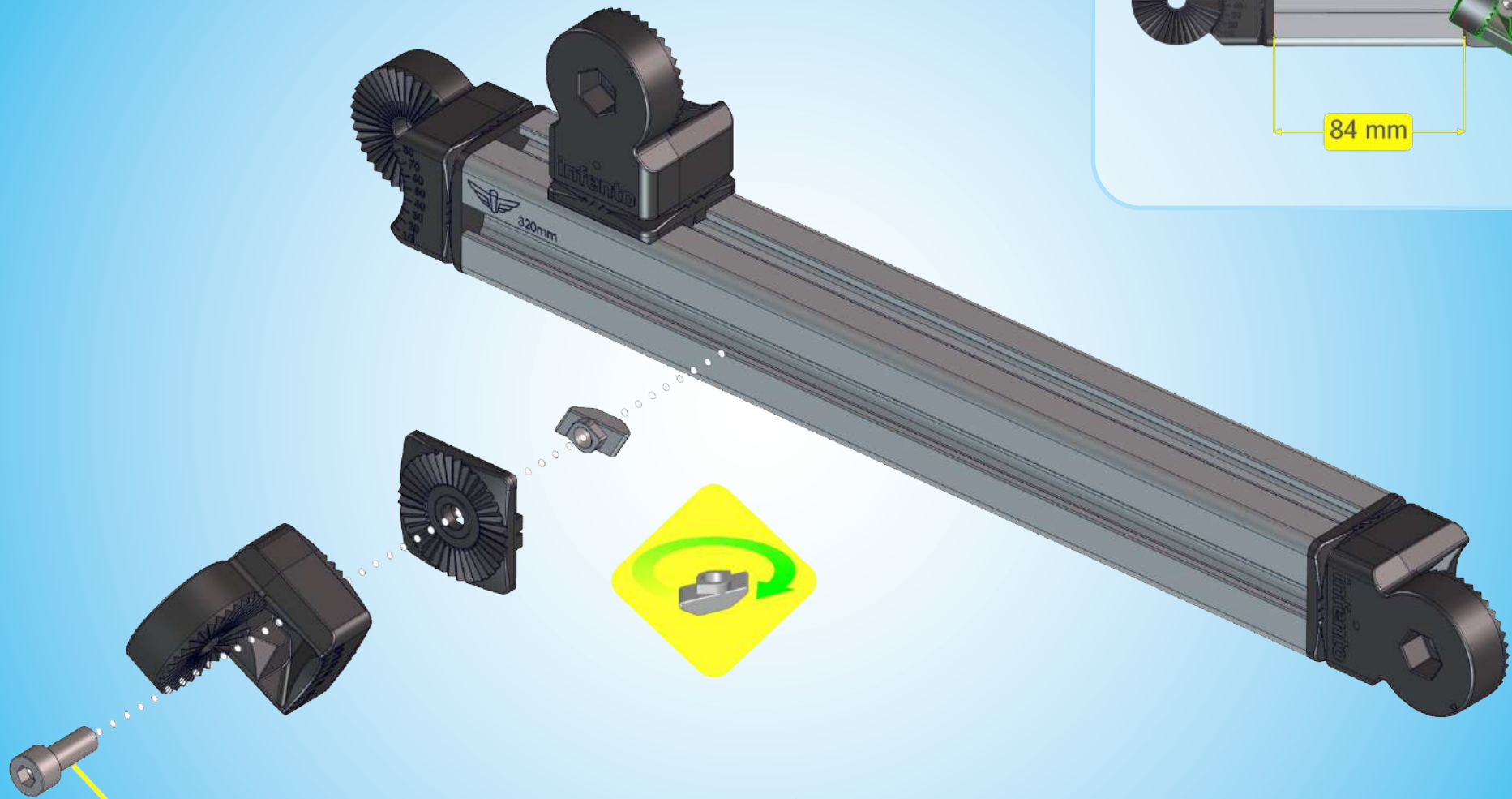

Bolt\_M8x20

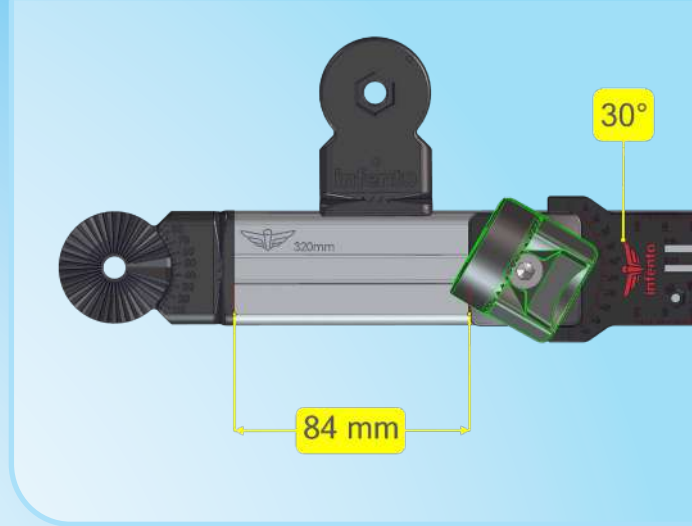

84 mm

30°

Bolt\_M8x12 Countersunk

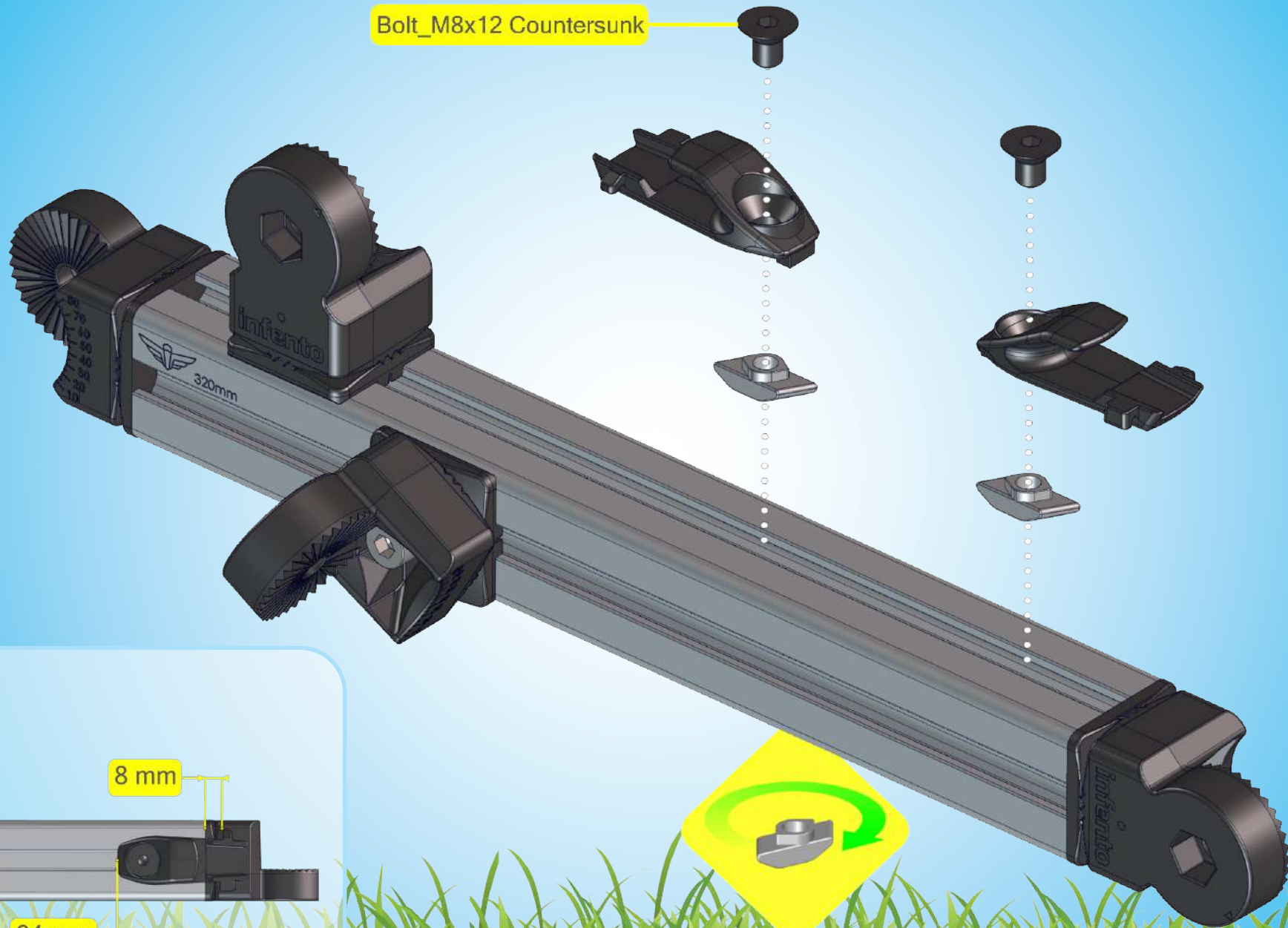

8 mm

64 mm

2x

Axle\_125mm

Bolt\_M8x25

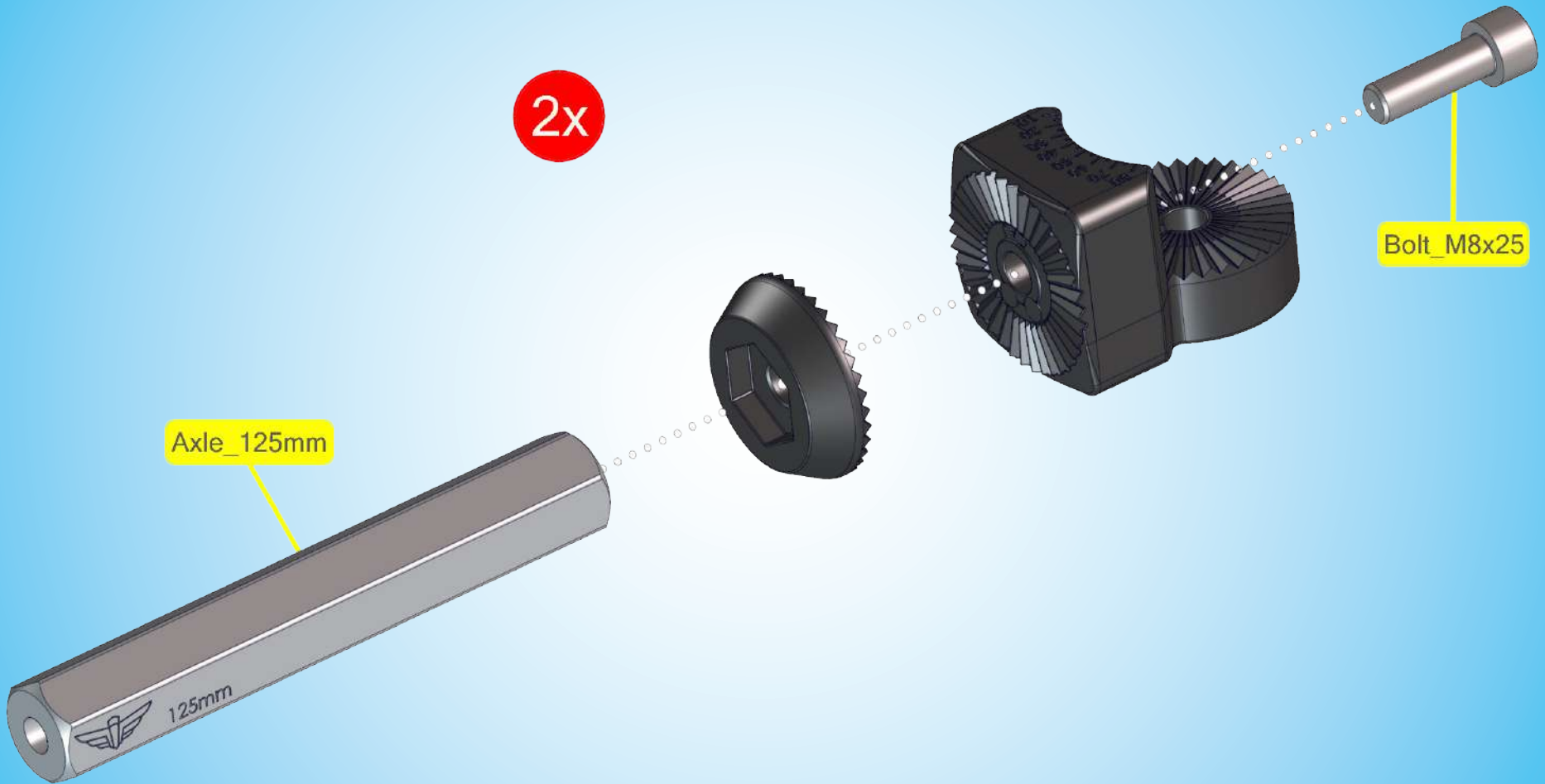

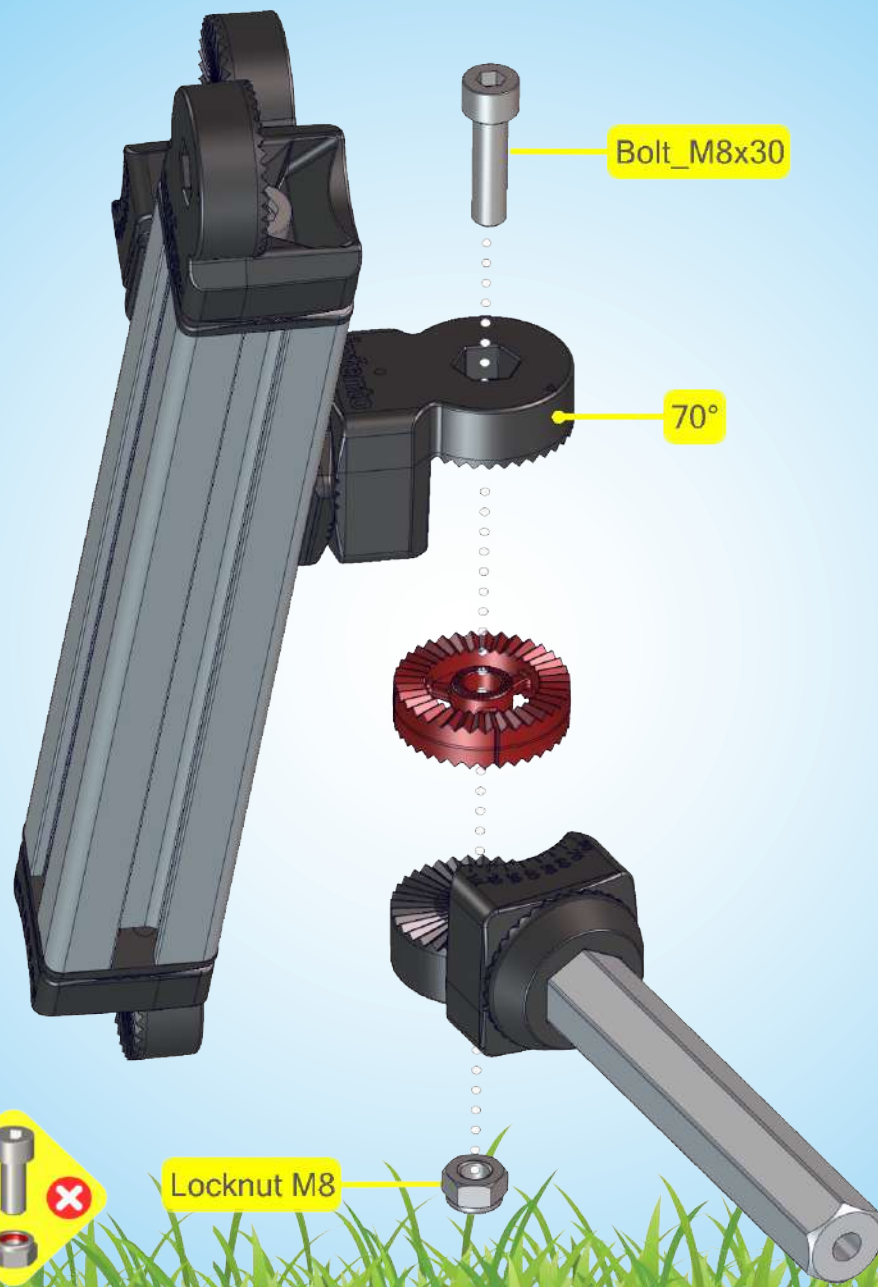

Locknut M8







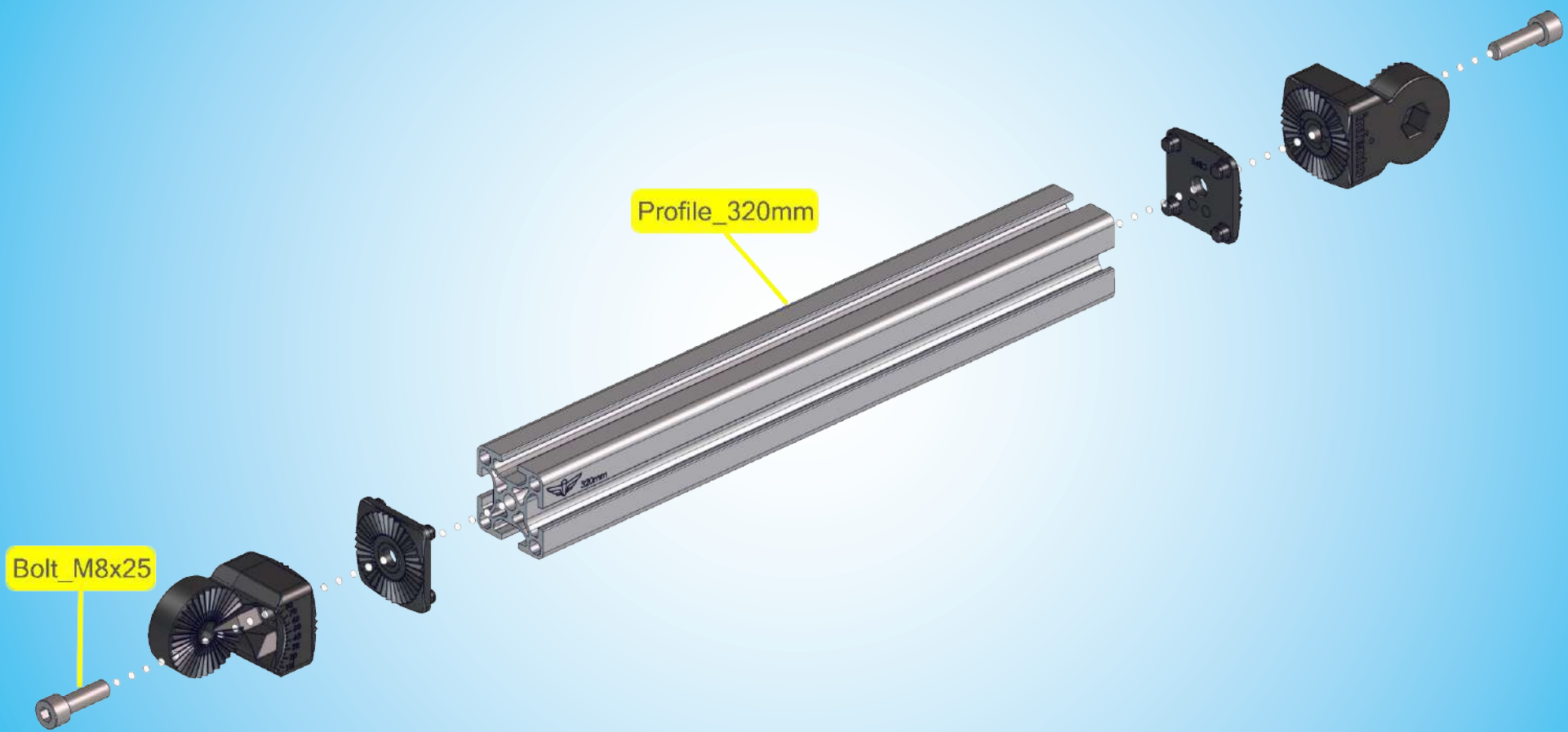

Bolt\_M8x20

31 mm







Bolt\_M8x12 Countersunk

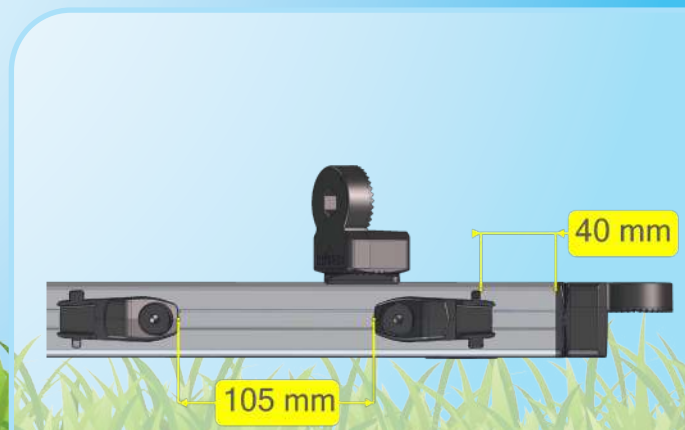

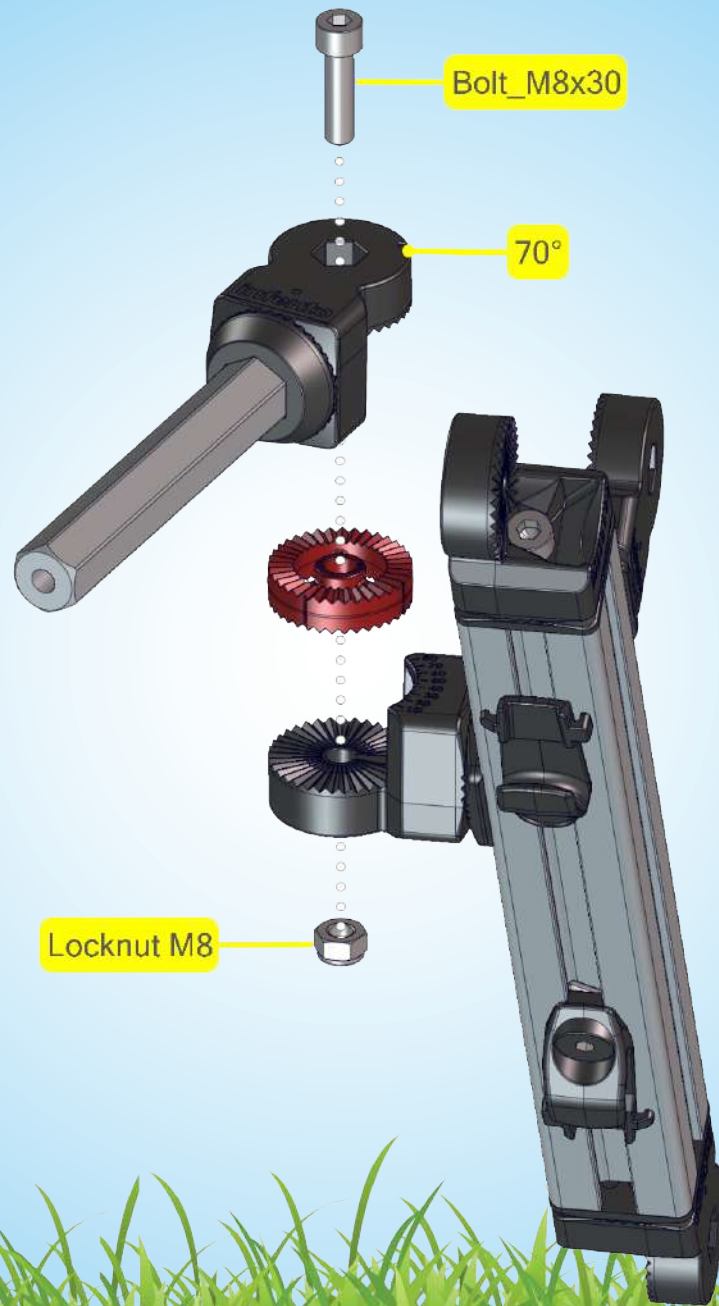







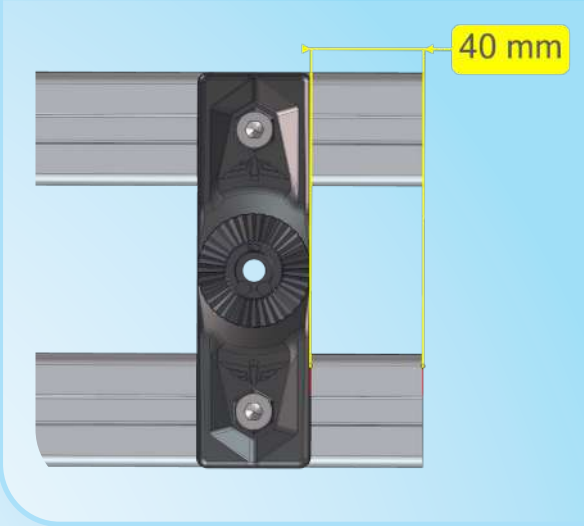
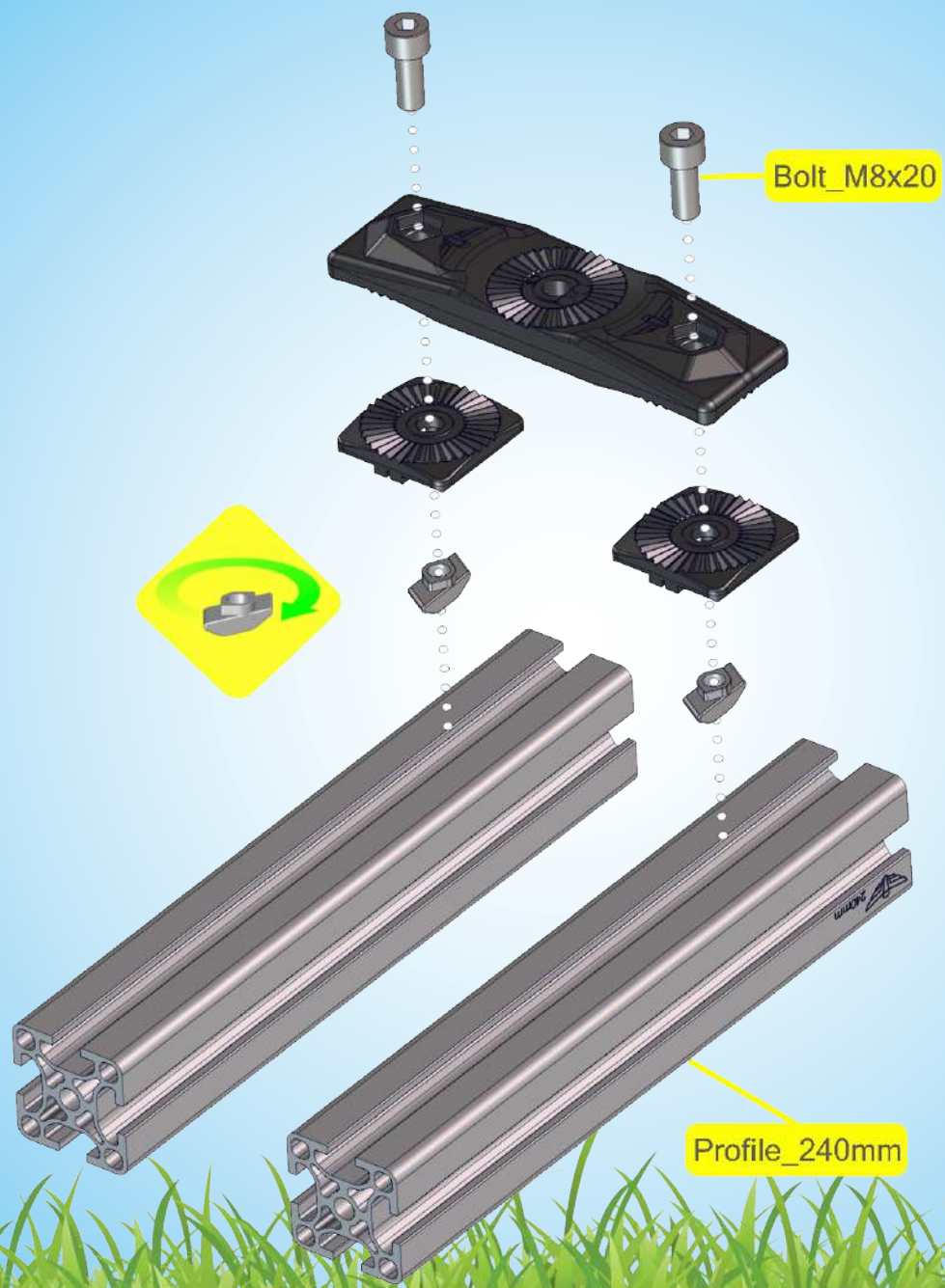

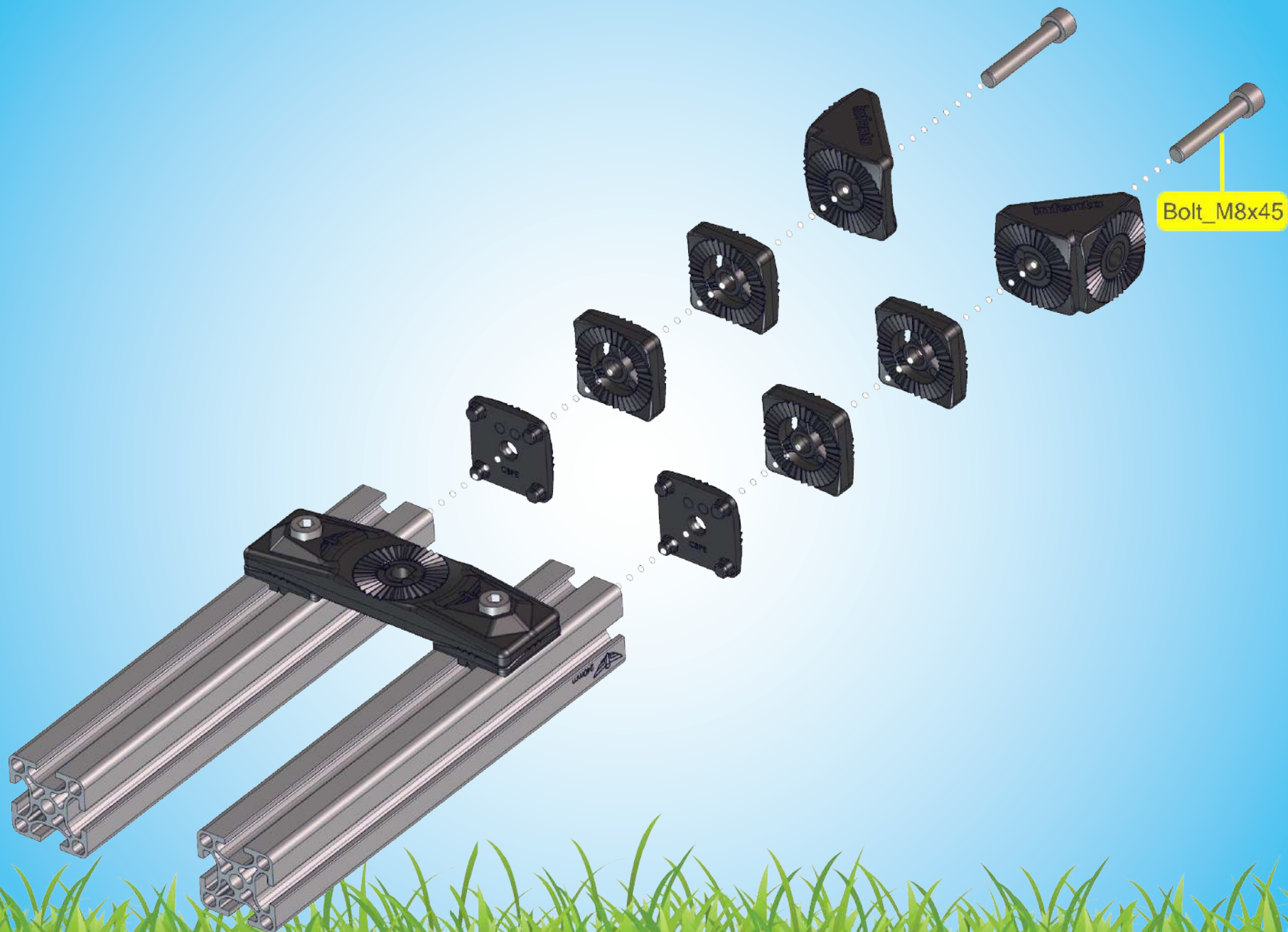

Bolt\_M8x45

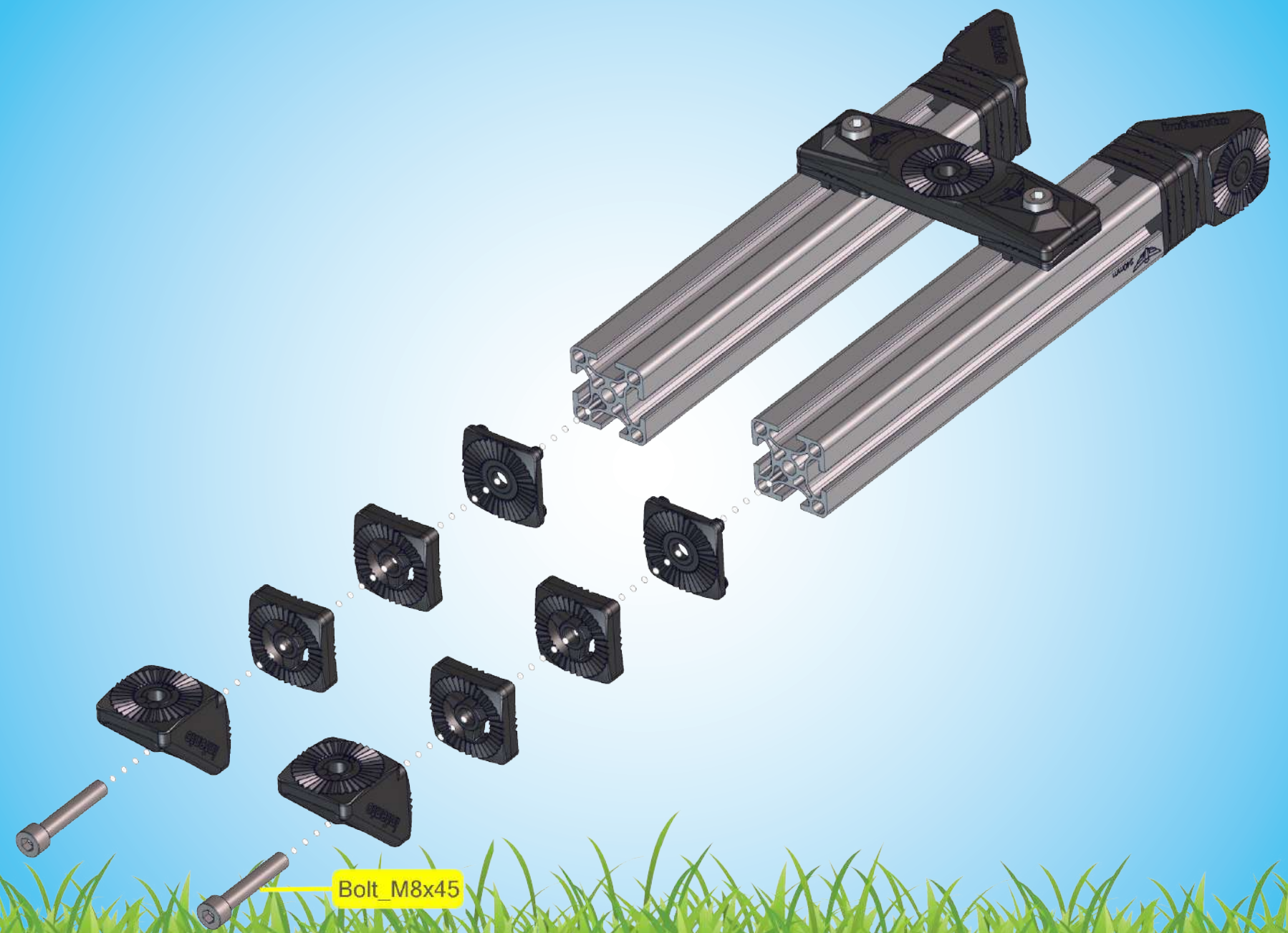

Bolt\_M8x45

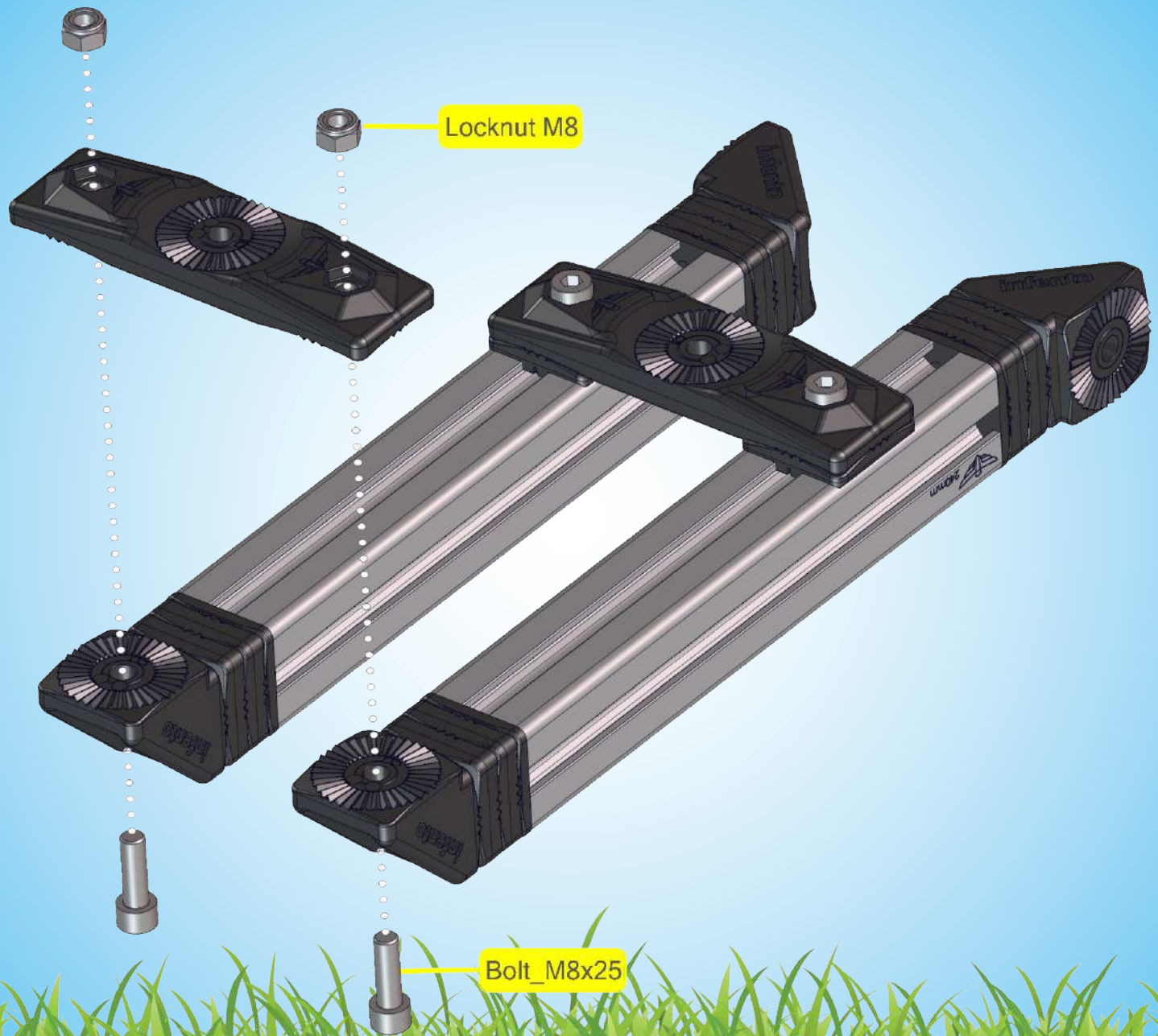

Locknut M8

Bolt\_M8x25

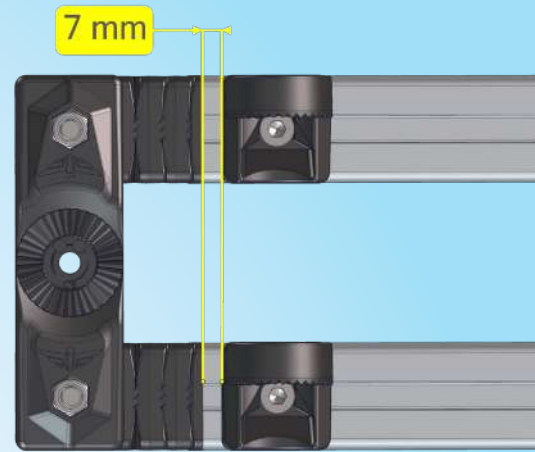
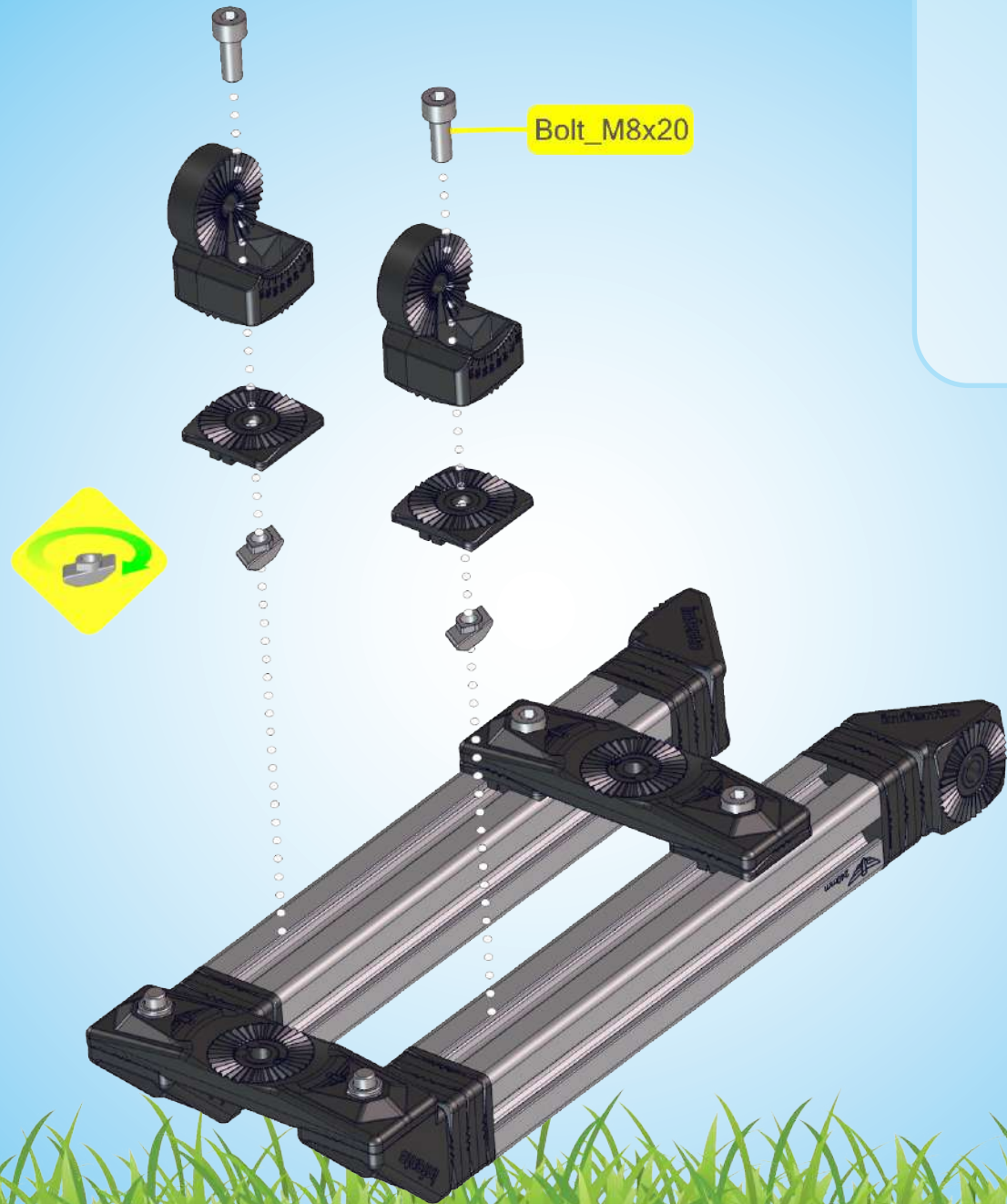

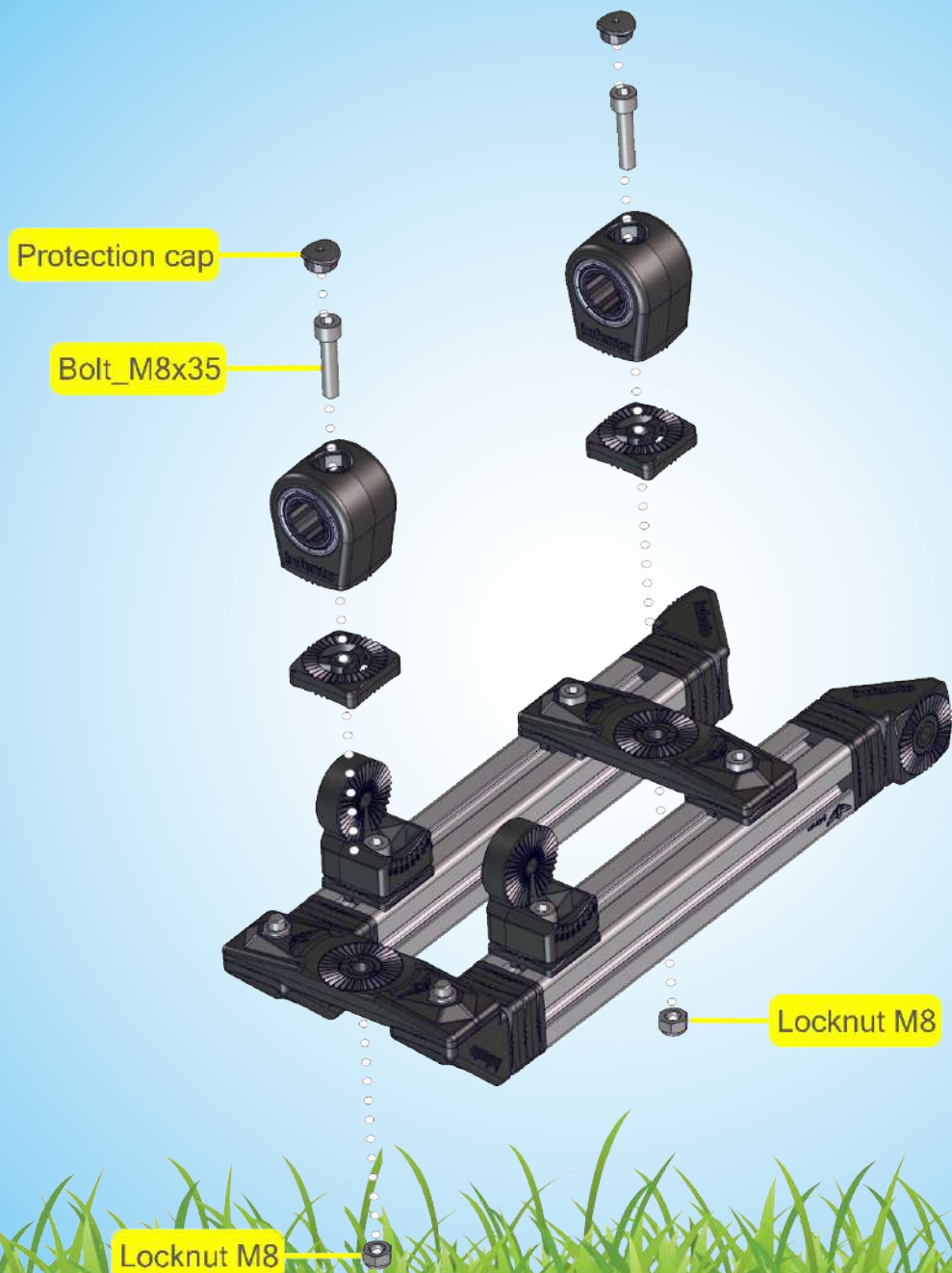

Bolt M6x12

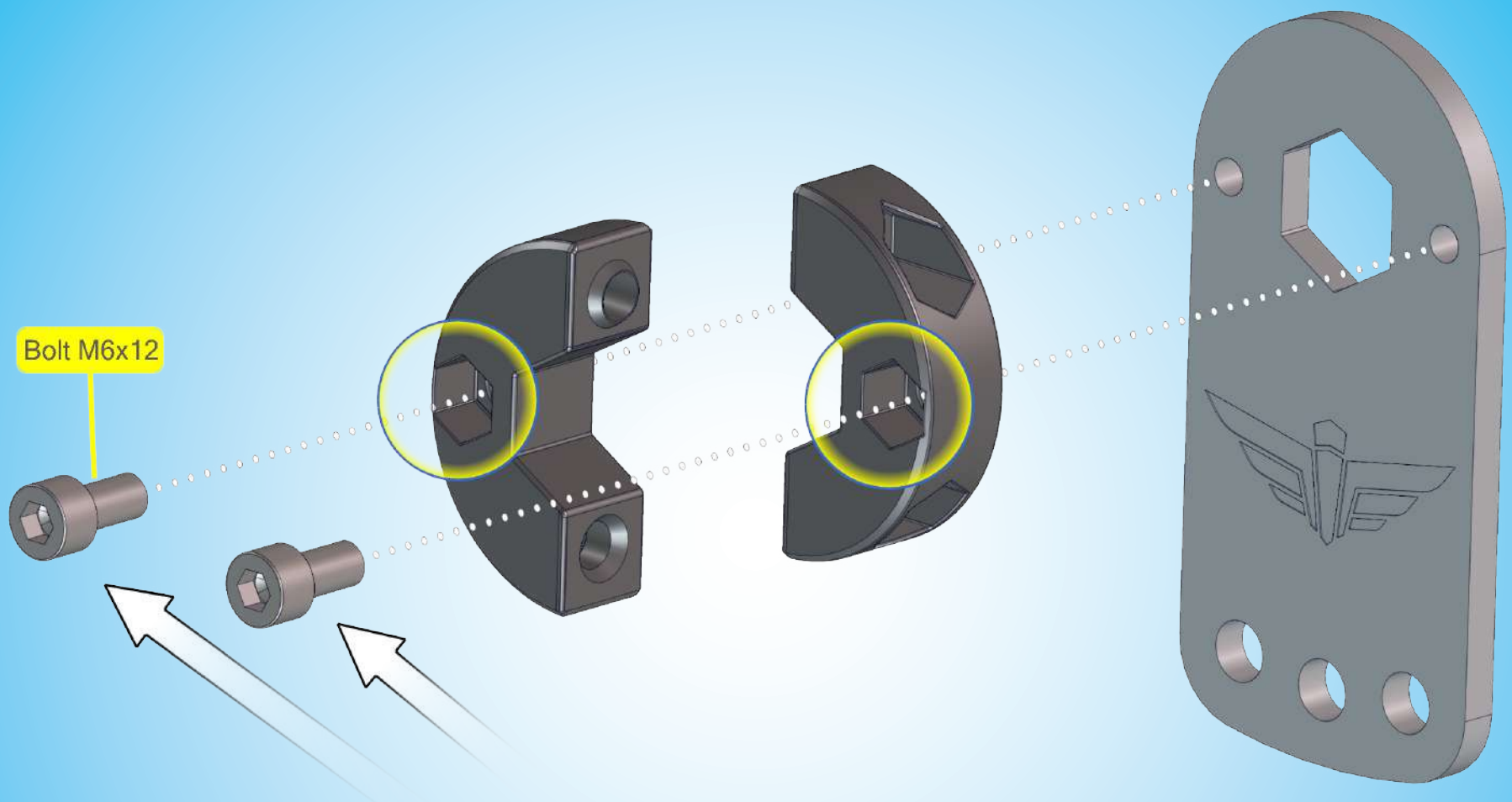

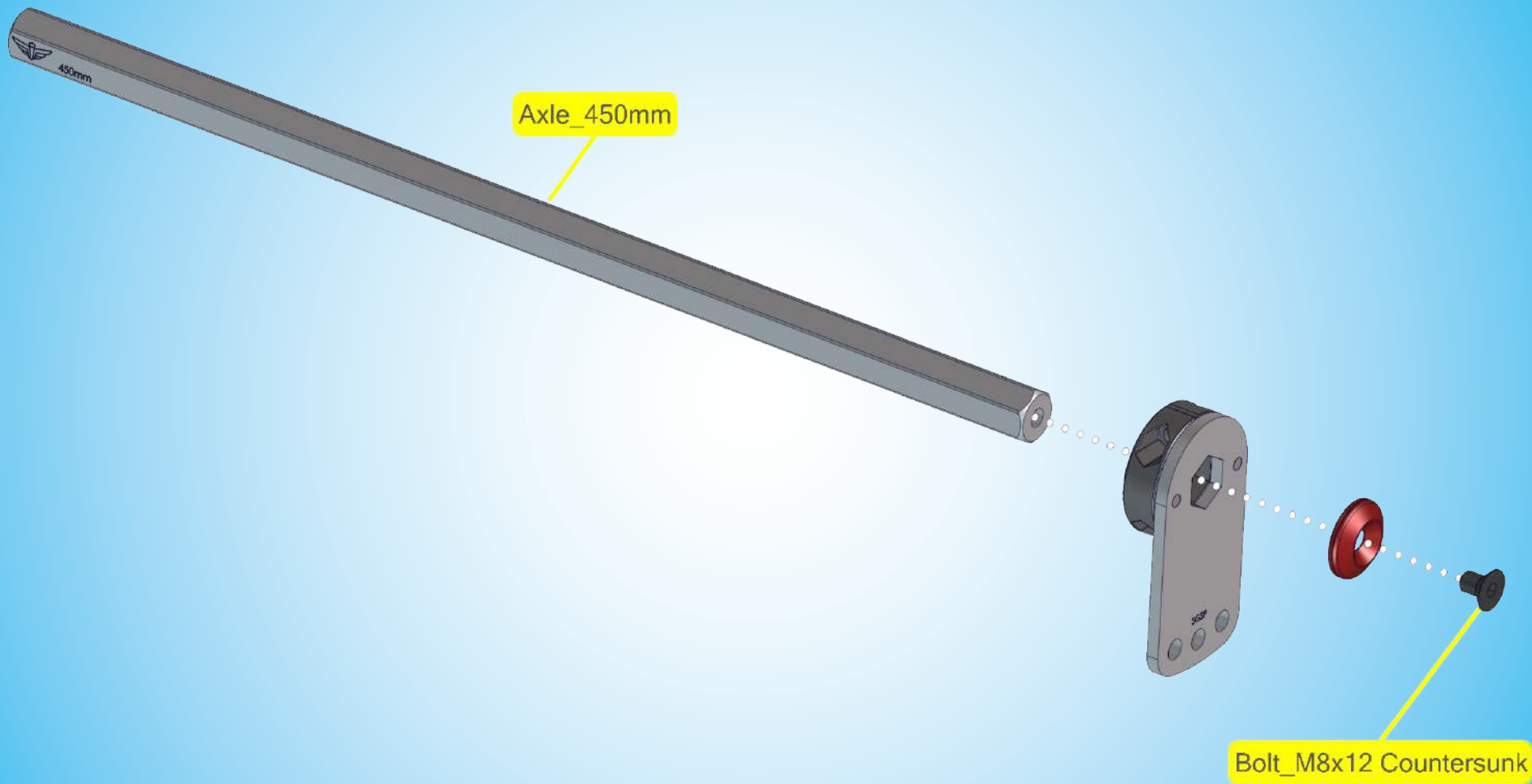

E.9

Locknut M6

Bolt\_M6x20

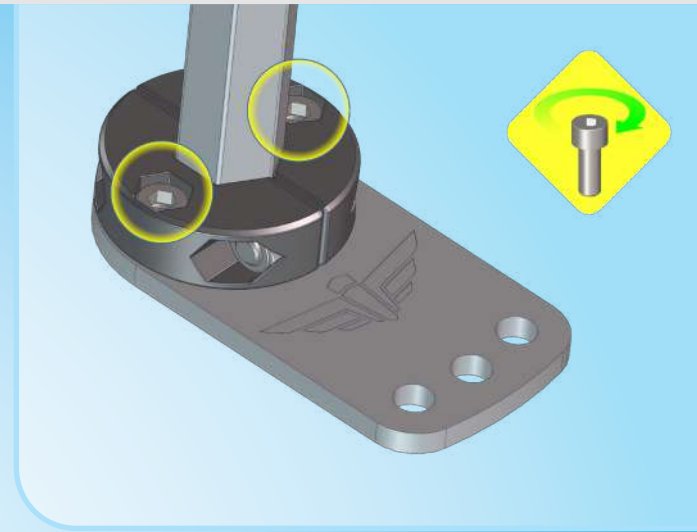

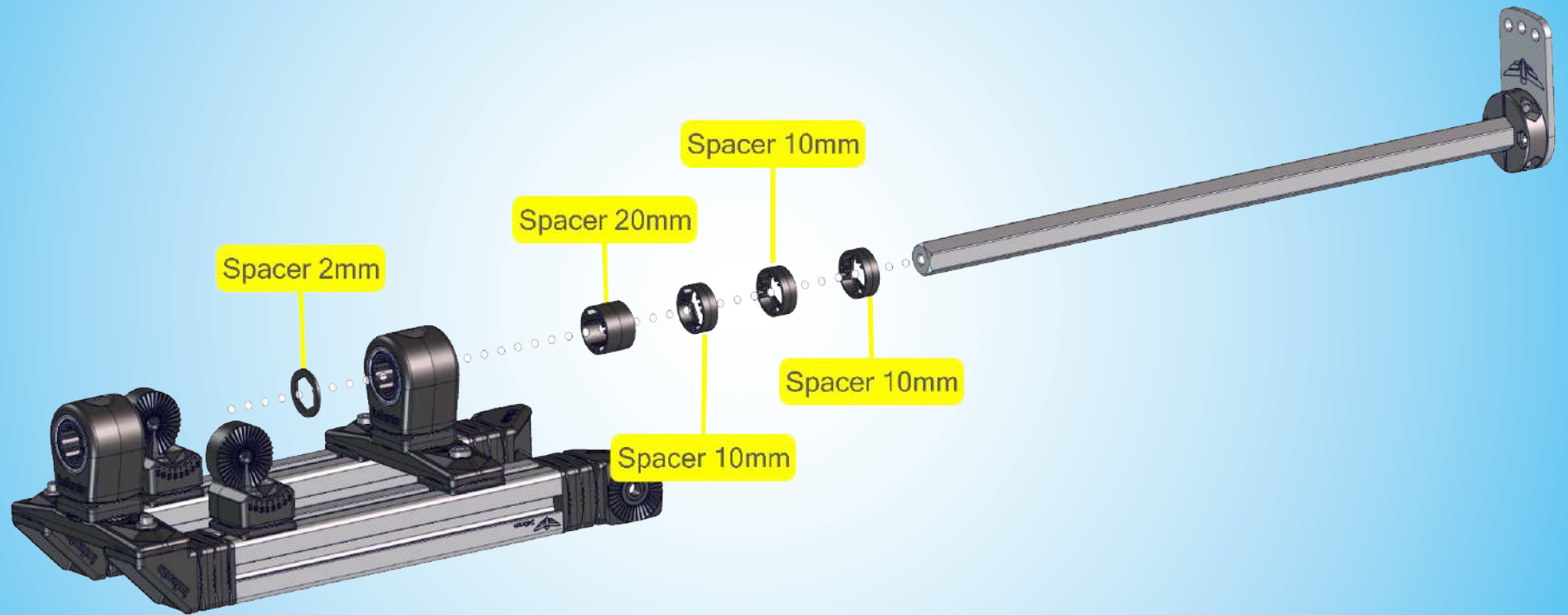

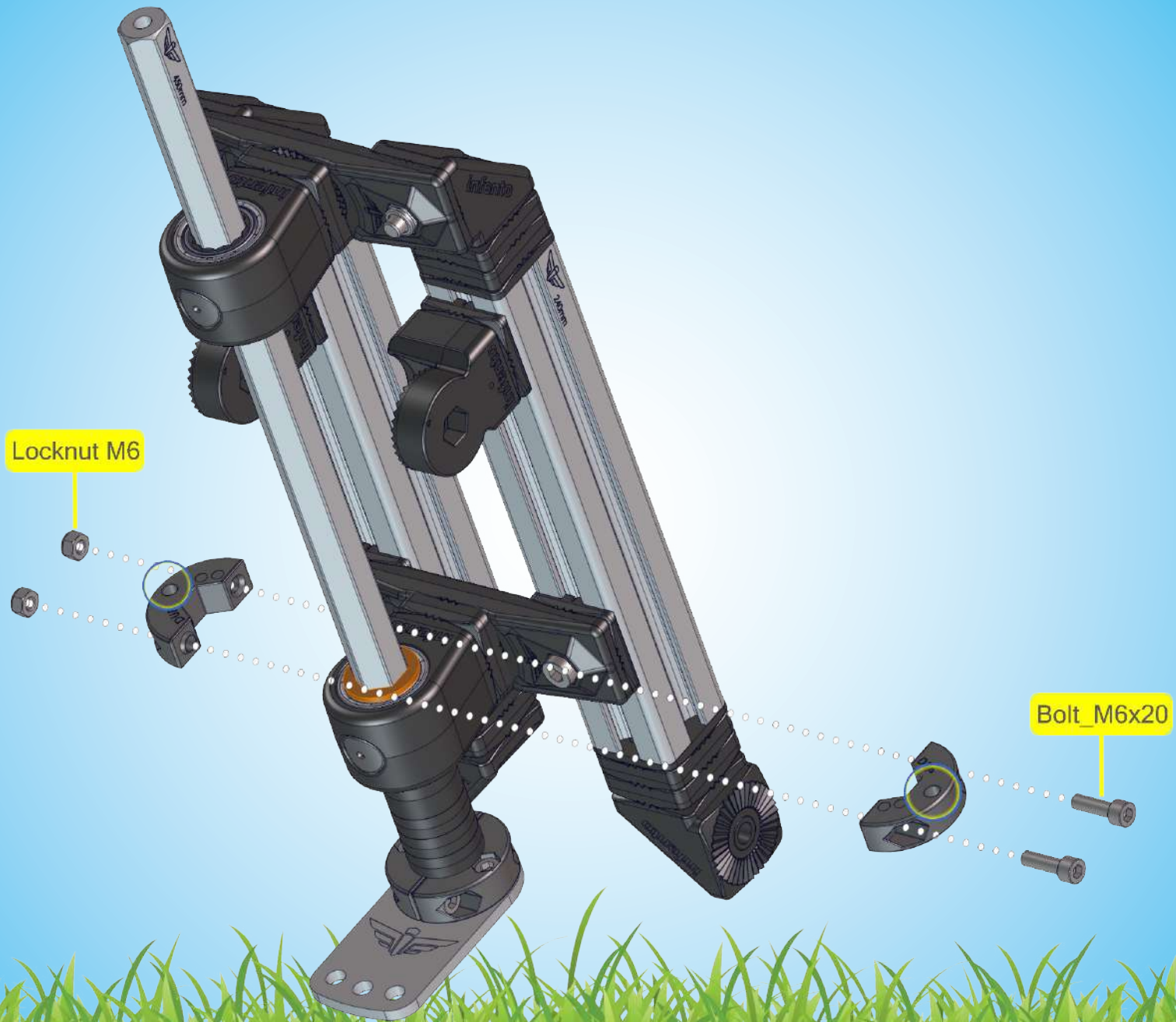

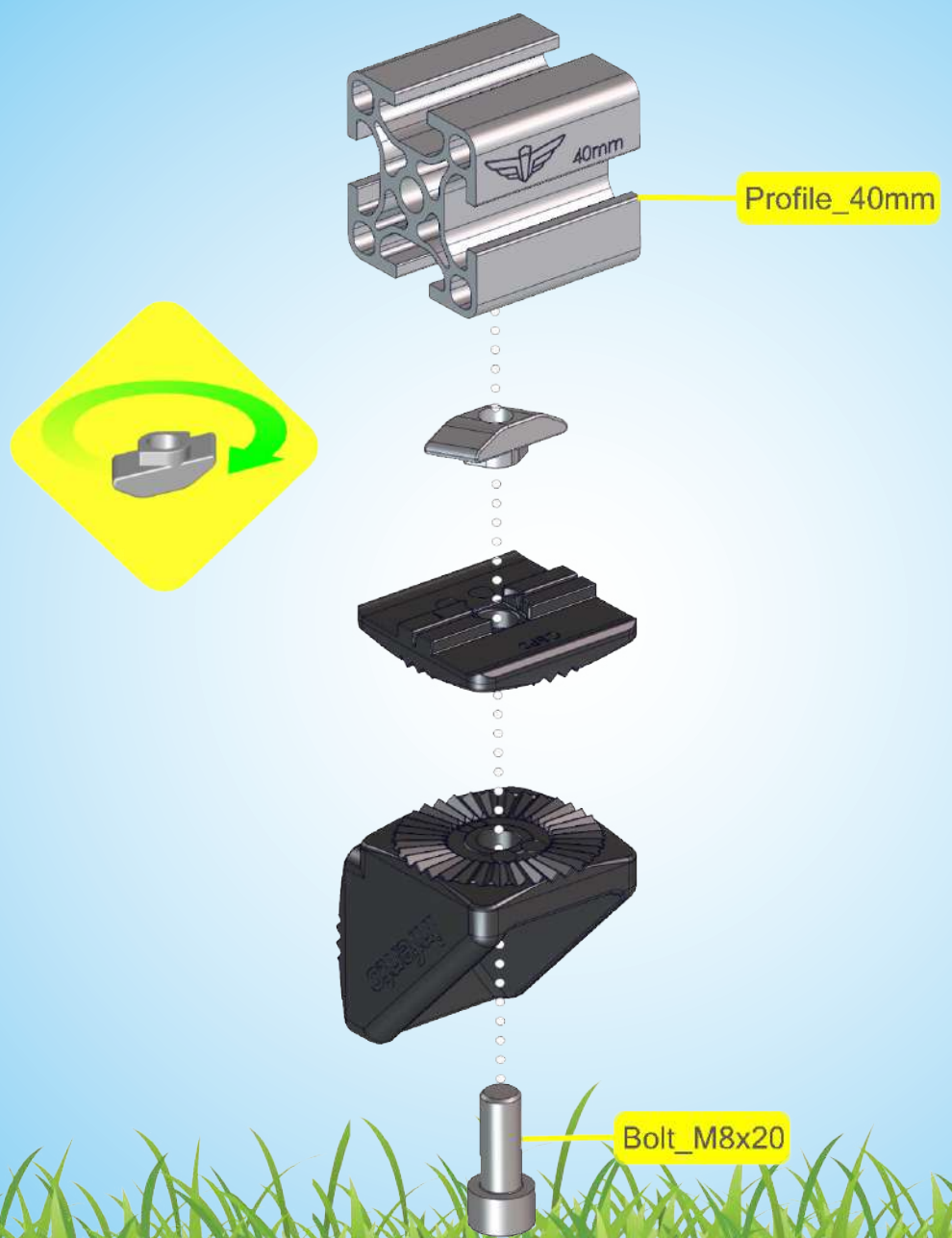

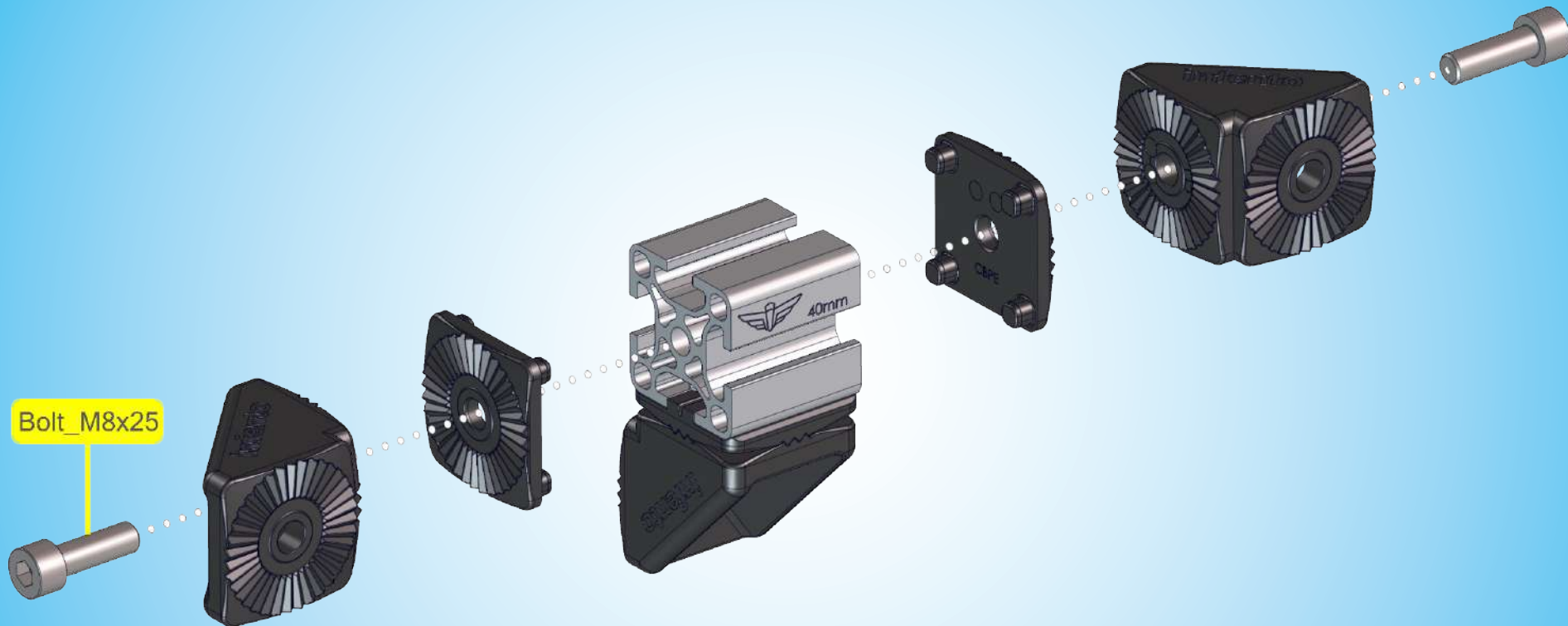



Bolt\_M8x25

Locknut M8

Bolt\_M8x25

Locknut M8



Bolt\_M8x12 Countersunk

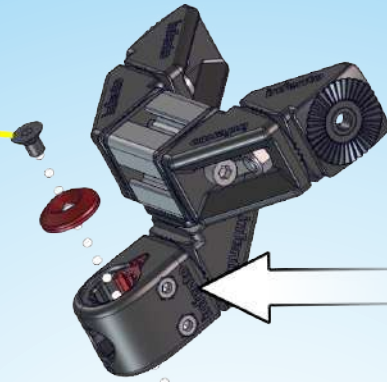

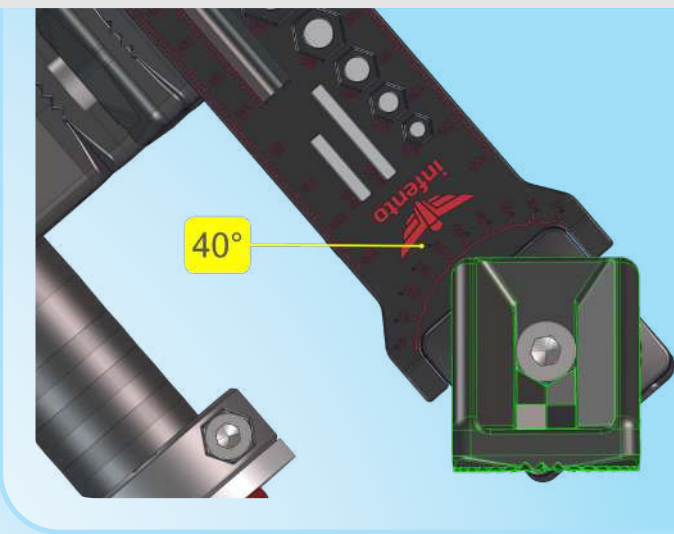
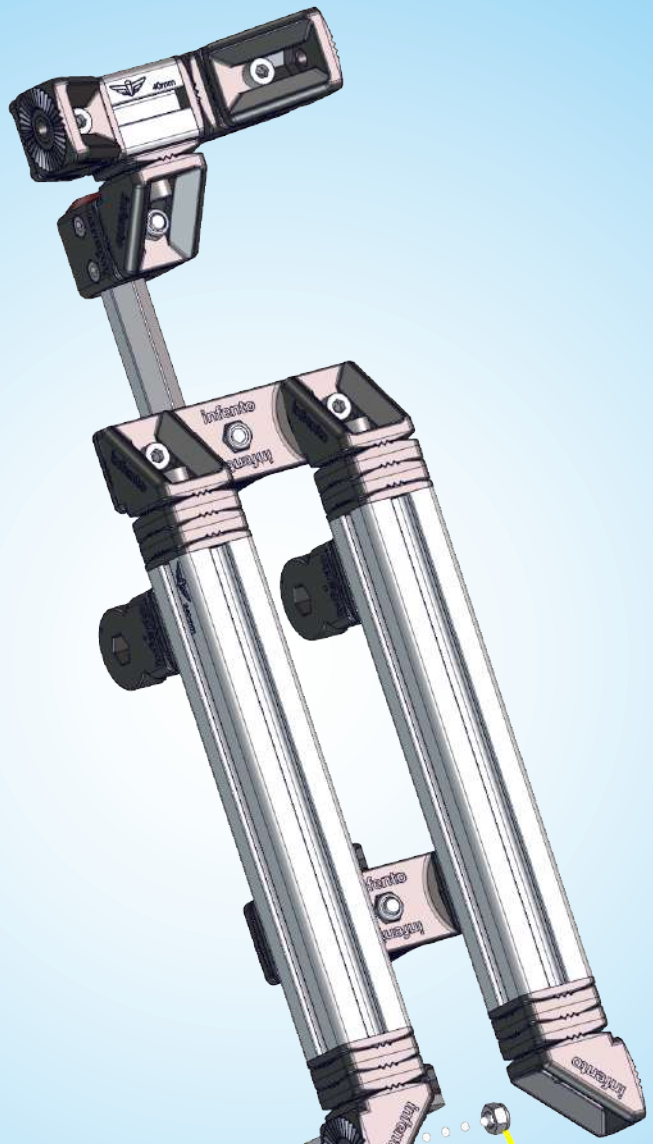

Bolt\_M8x35



Locknut M8



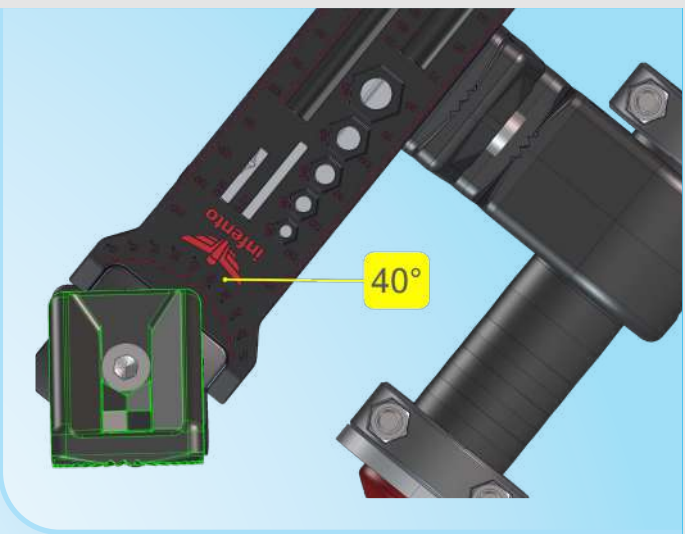

Locknut M8

Bolt\_M8x35





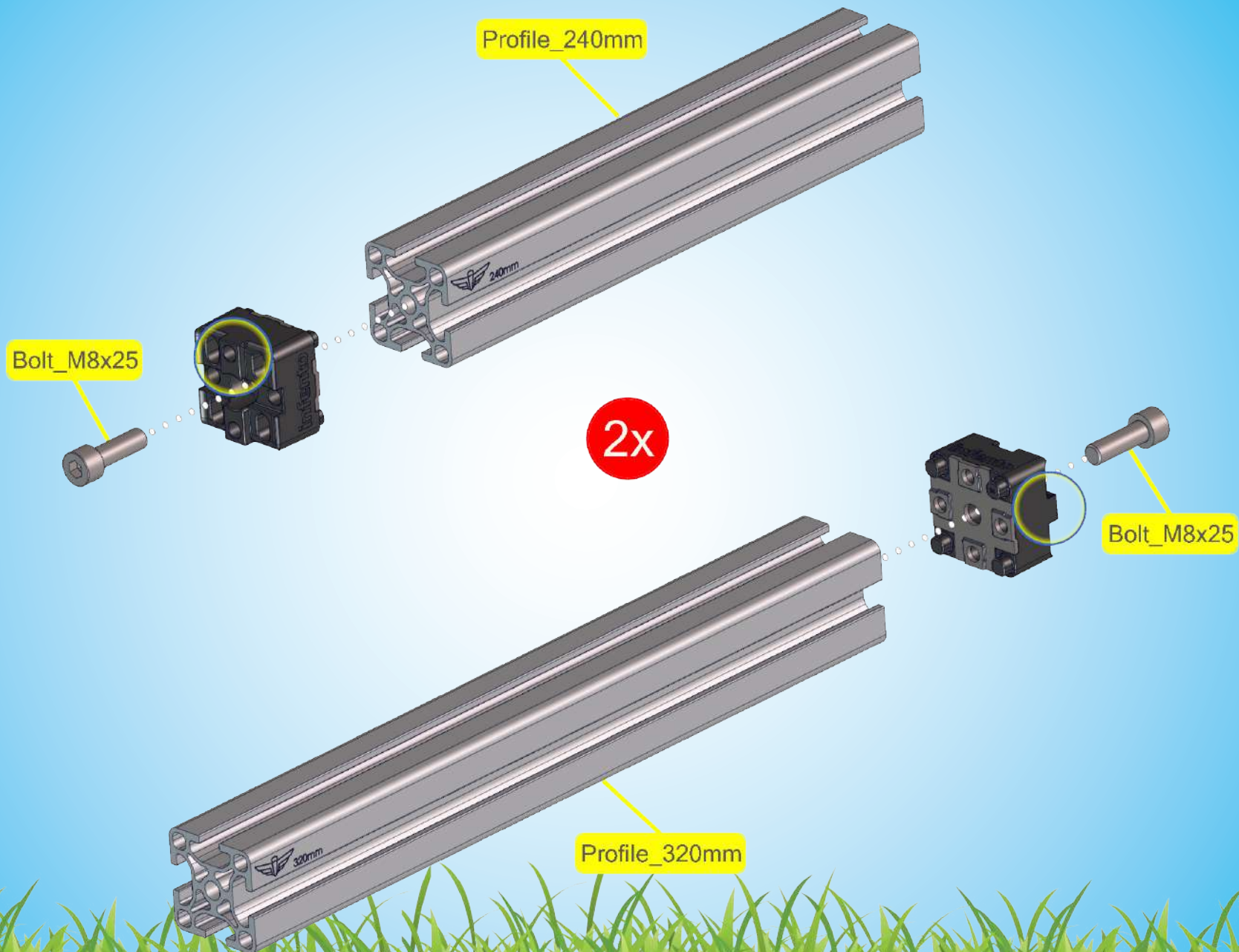

2x

Square nut M6

LockBolt\_M6x50

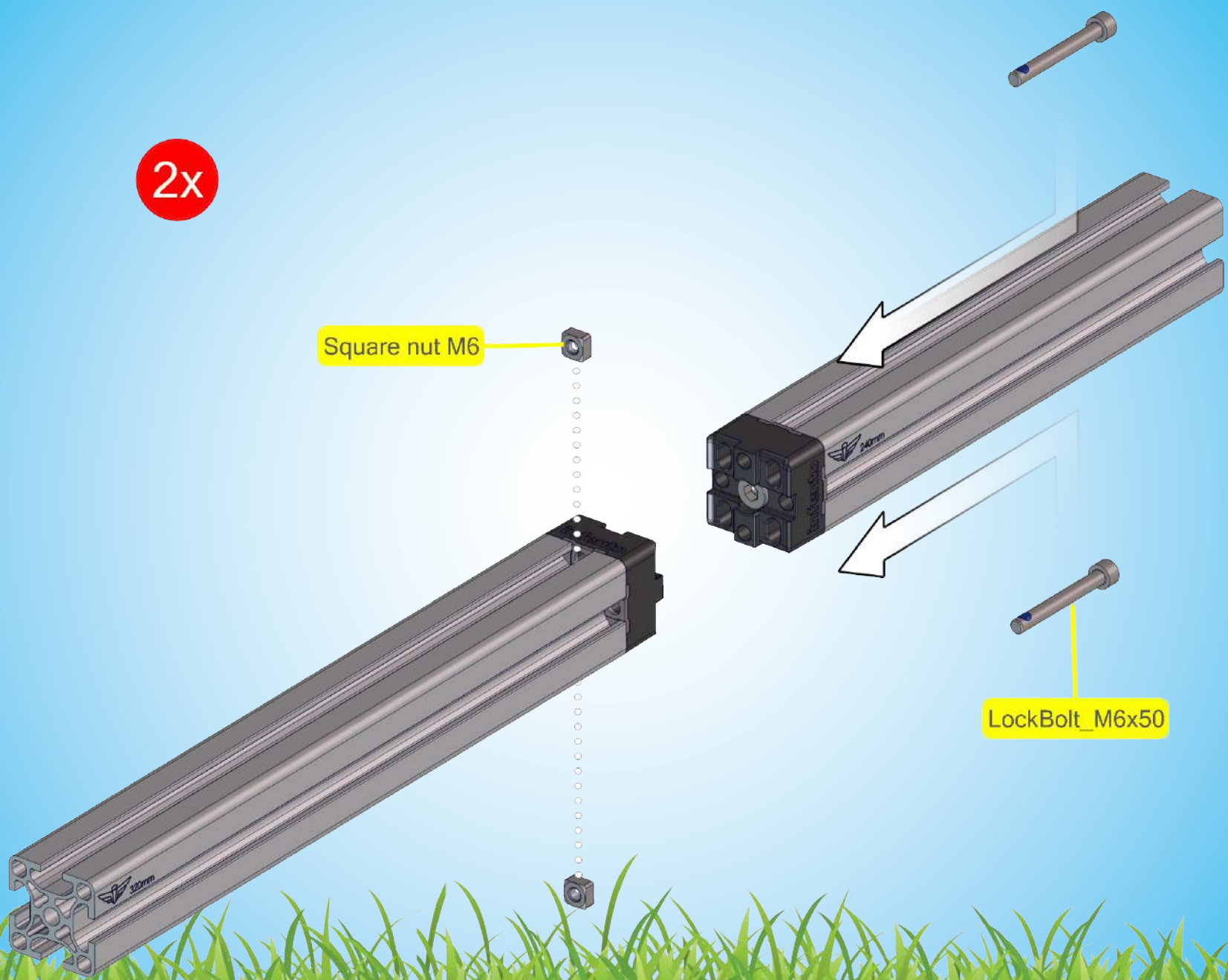

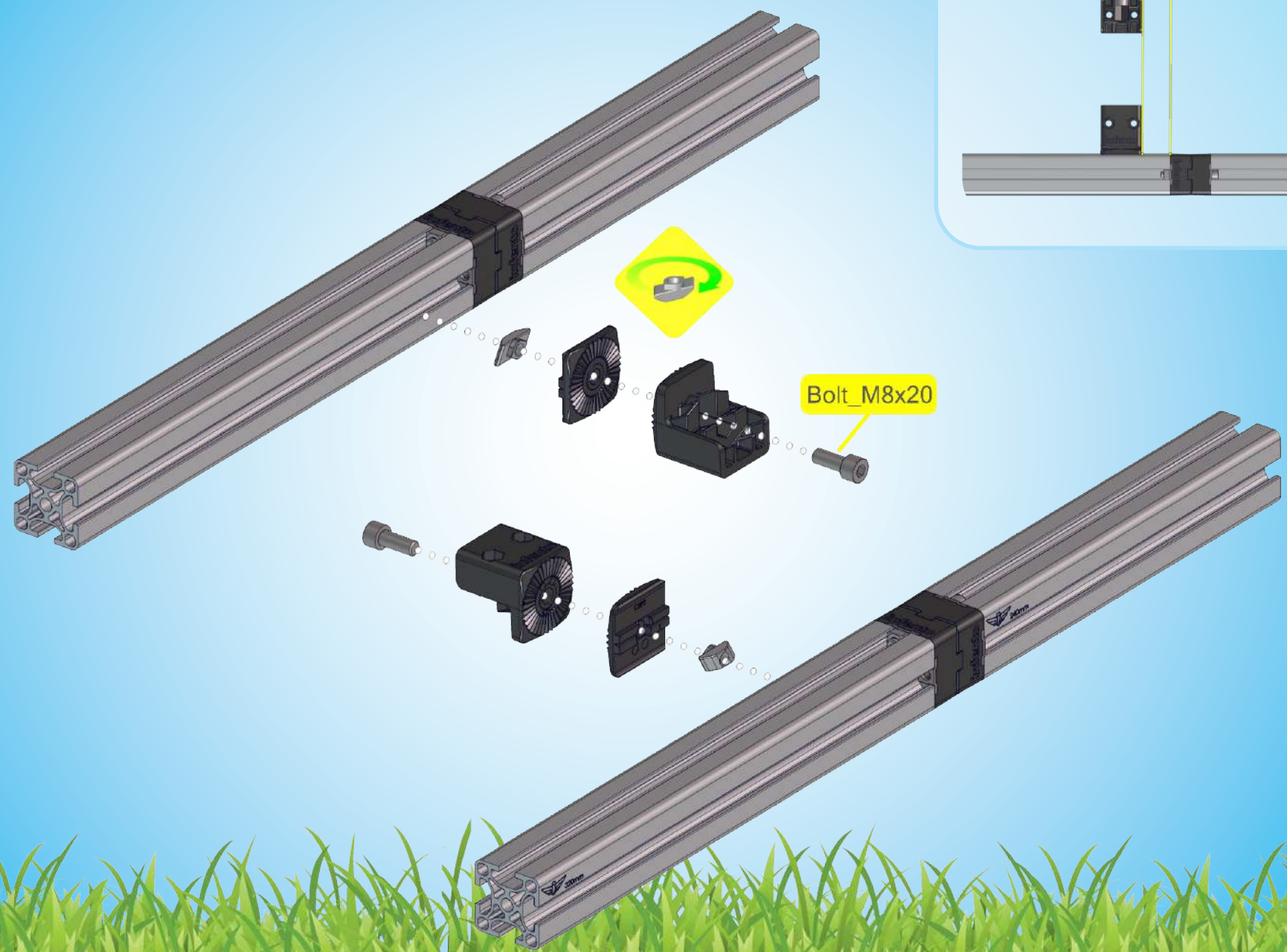
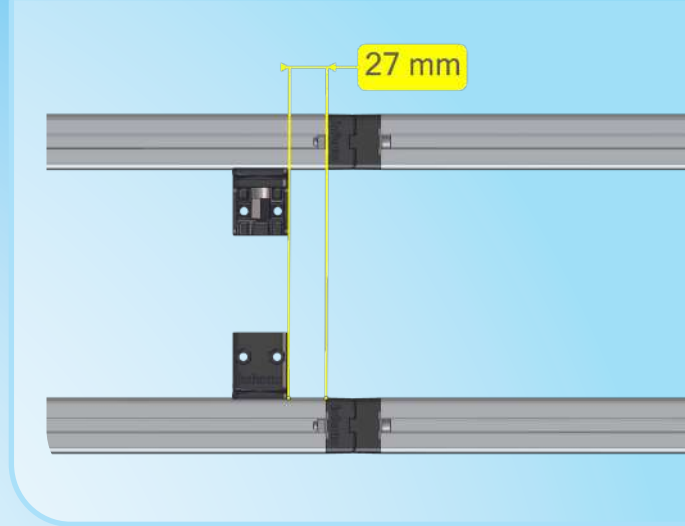



Bolt\_M6x35

Locknut M6



Bolt\_M8x20

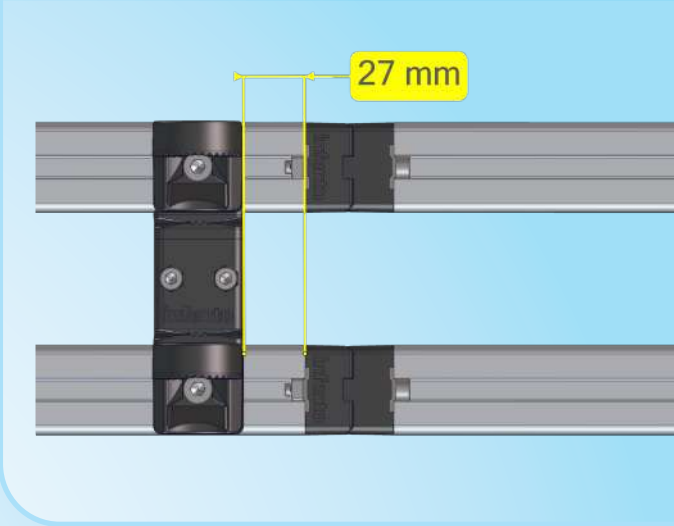

27 mm



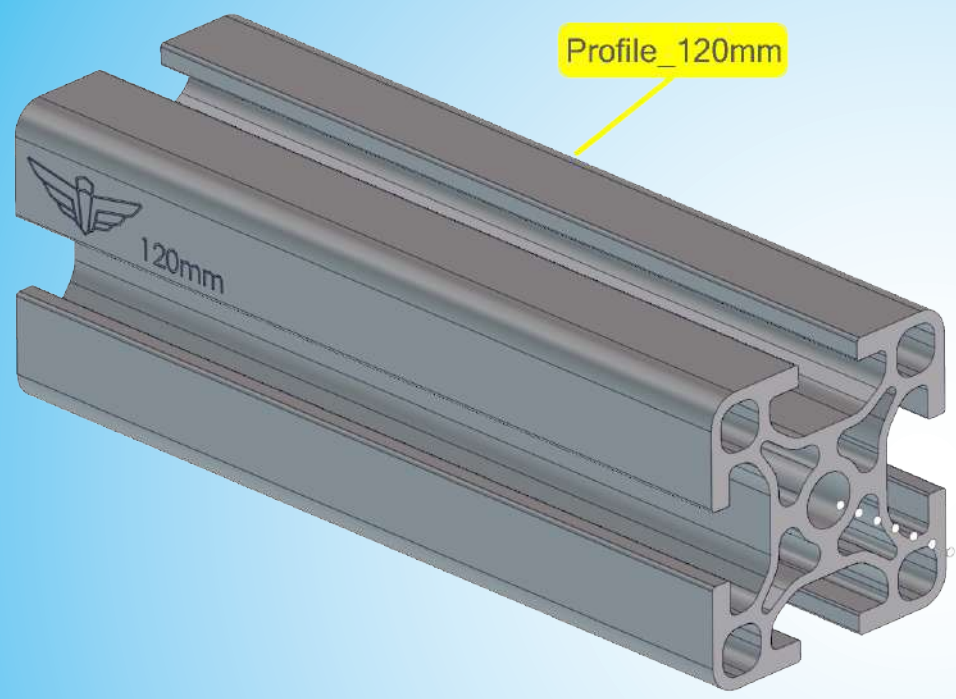

2x

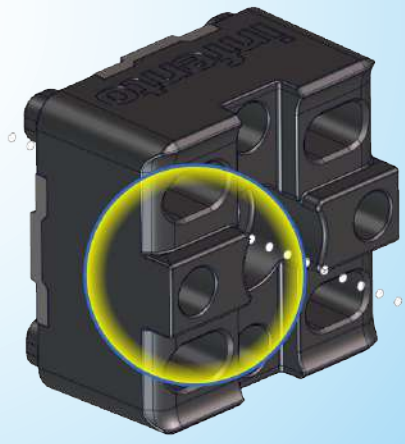

Bolt\_M8x25

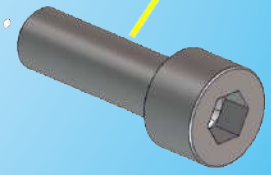

F.7

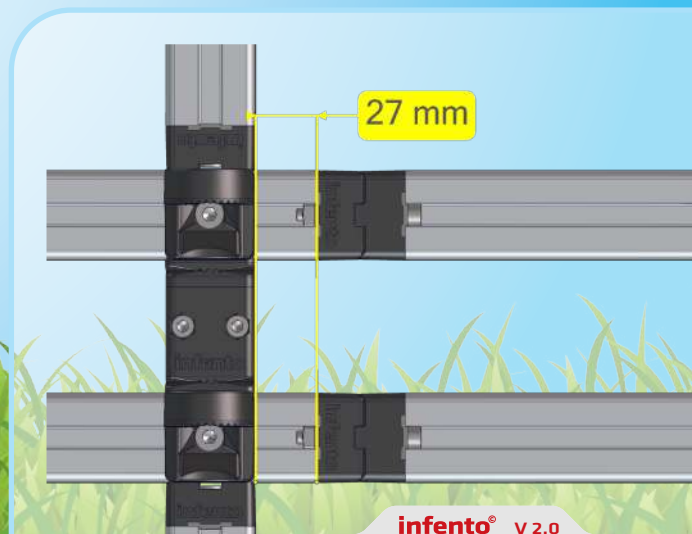
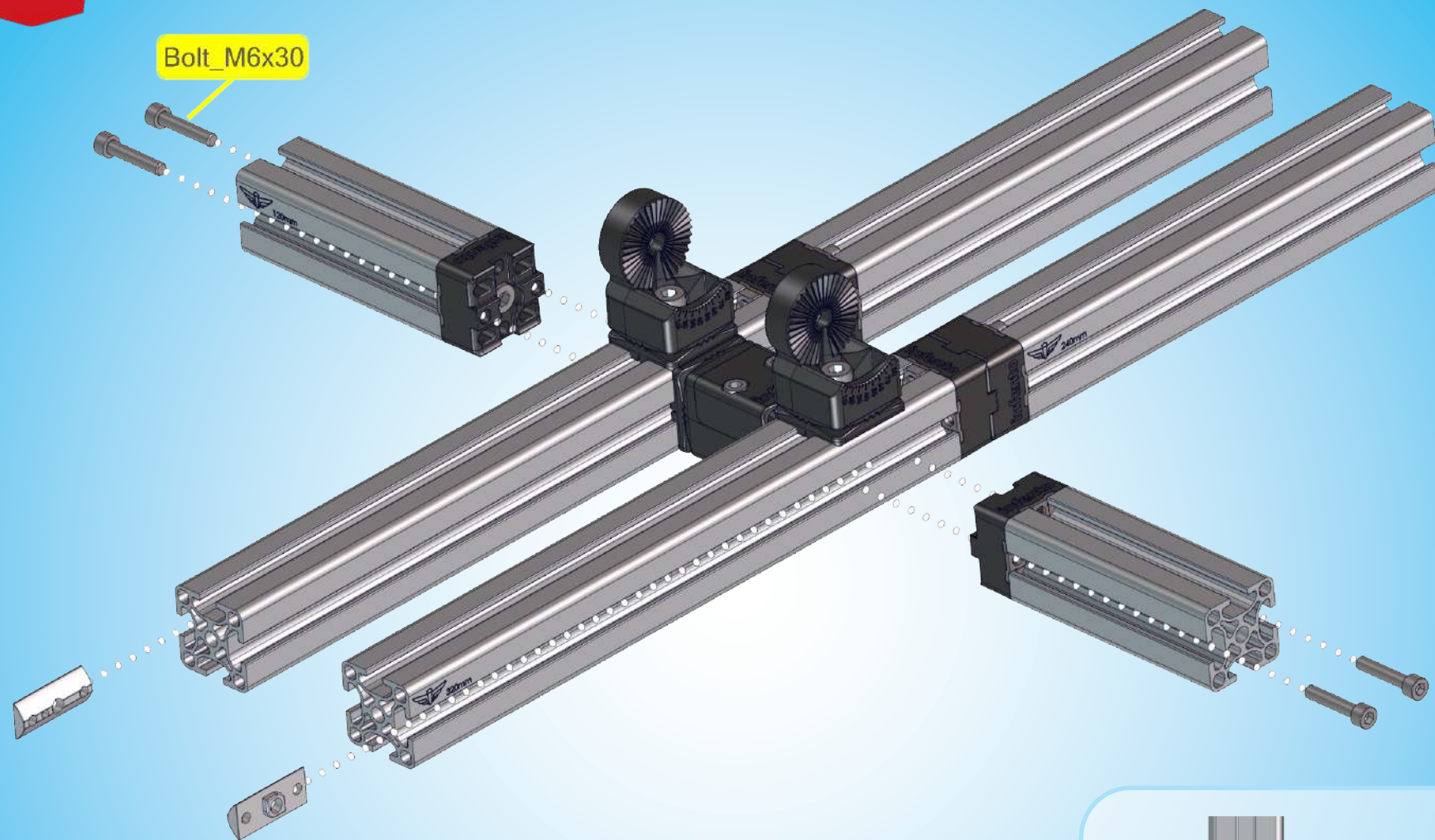

Bolt\_M8x12 Countersunk



Bolt\_M8x12 Countersunk

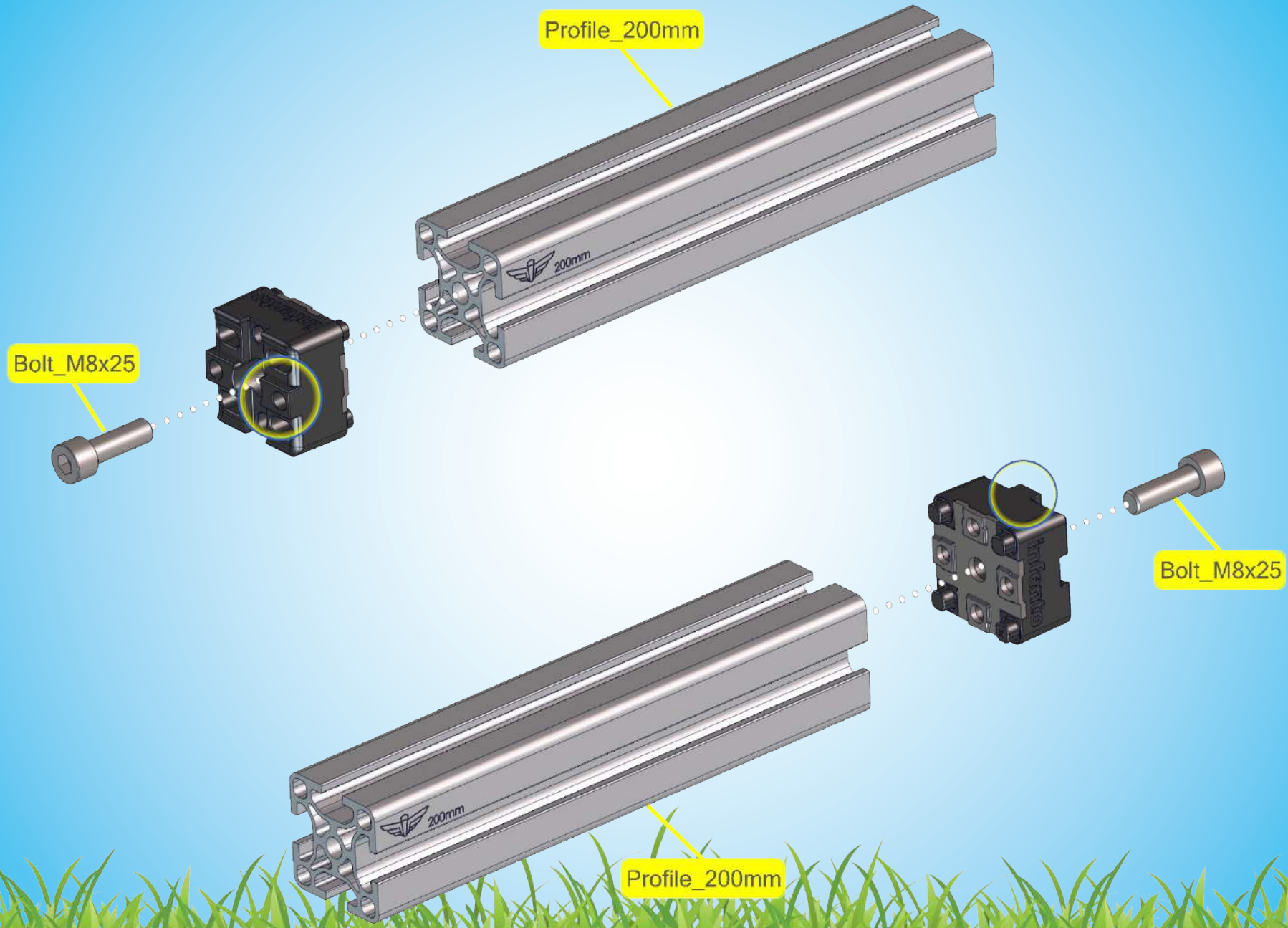

LockBolt\_M6x50

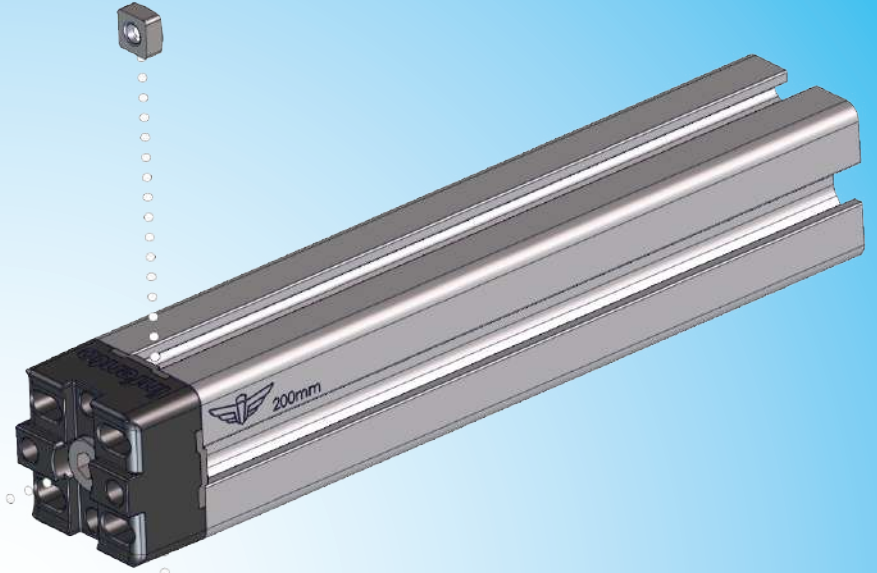
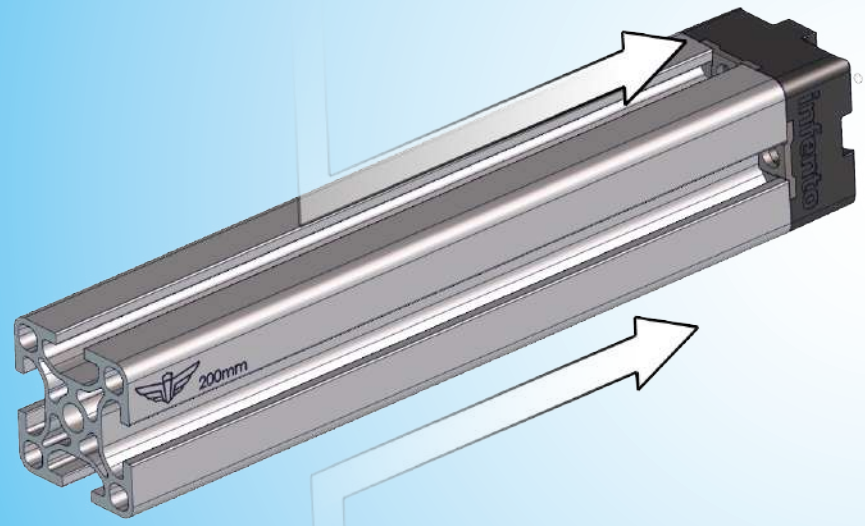
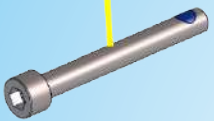

Square nut M6



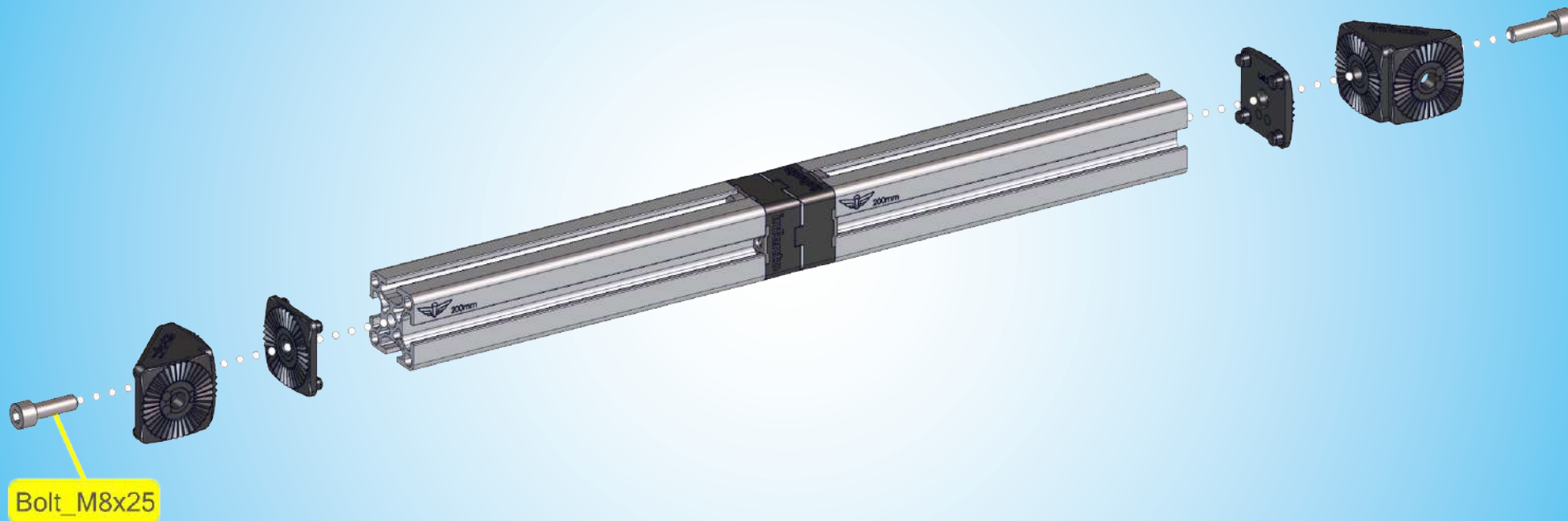

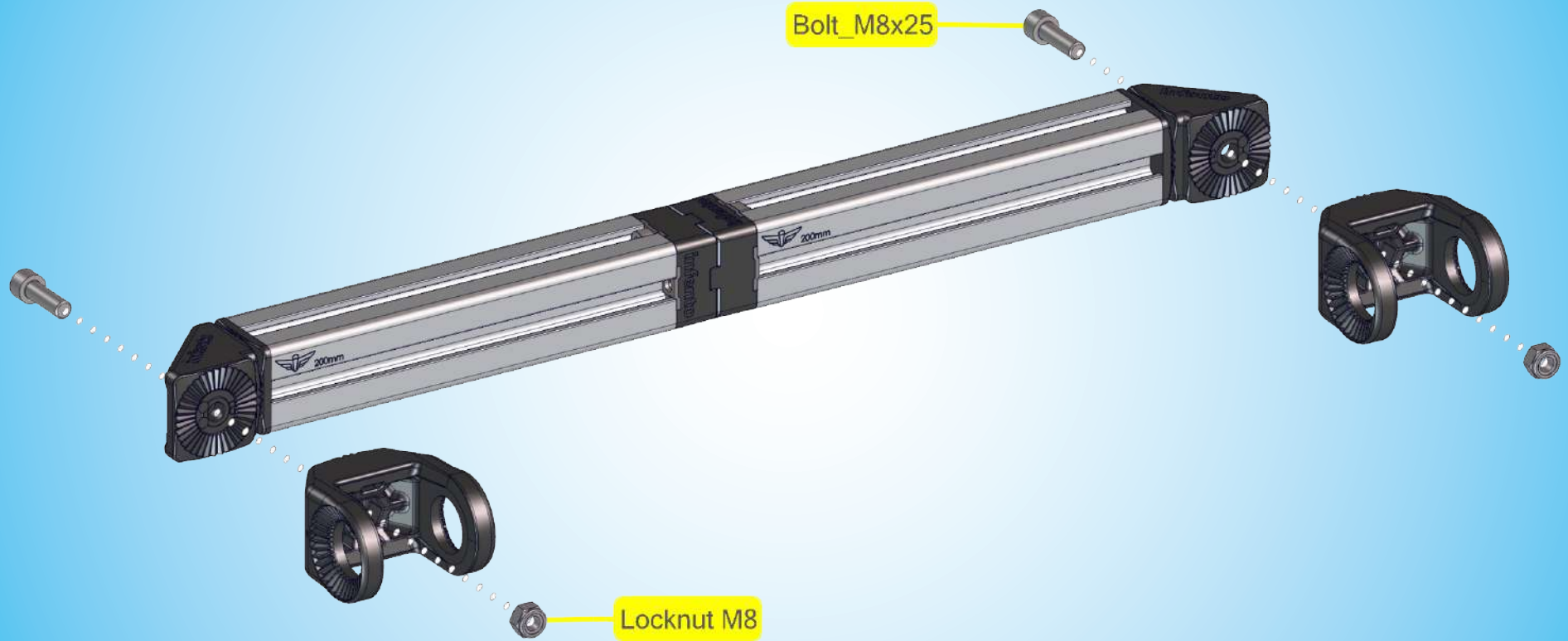

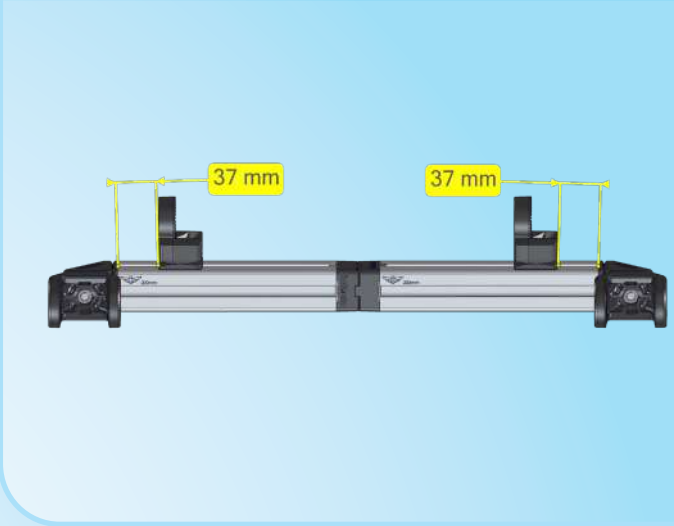
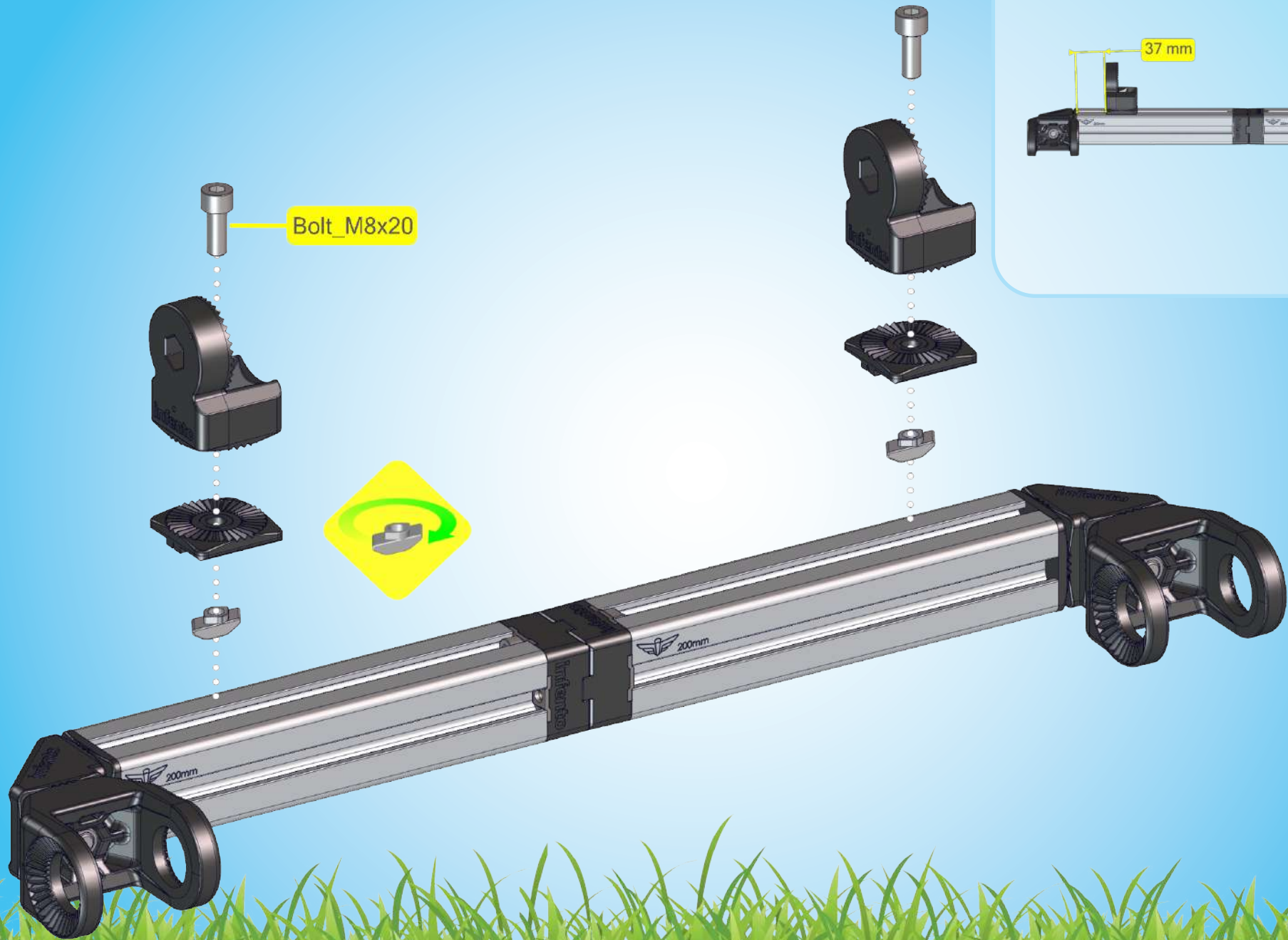

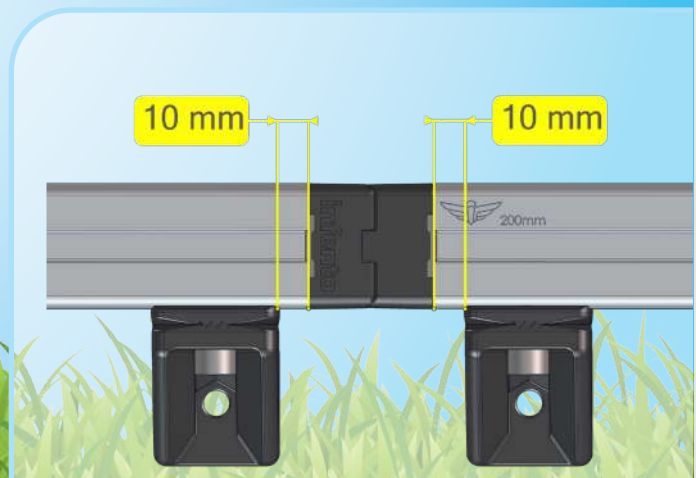
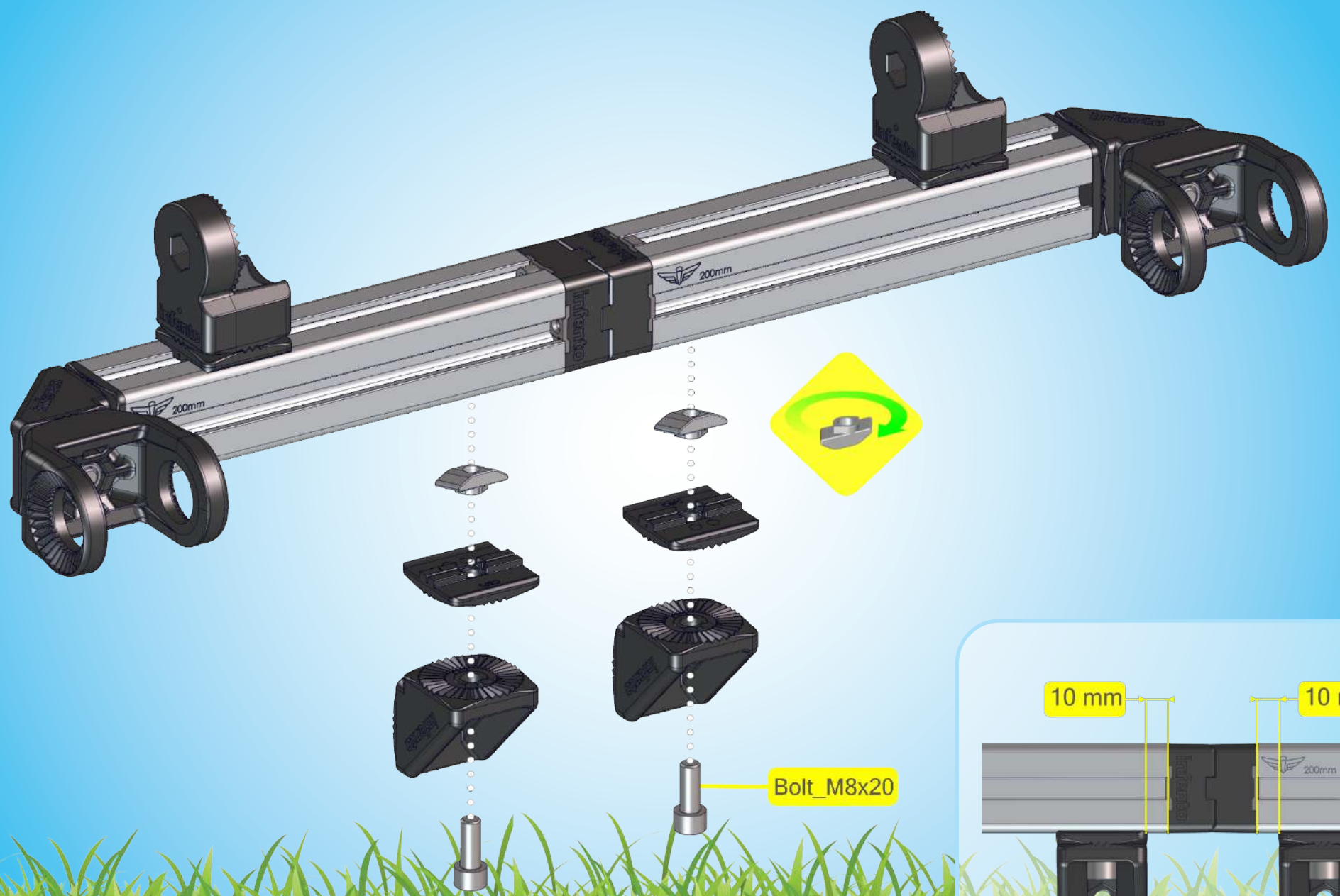

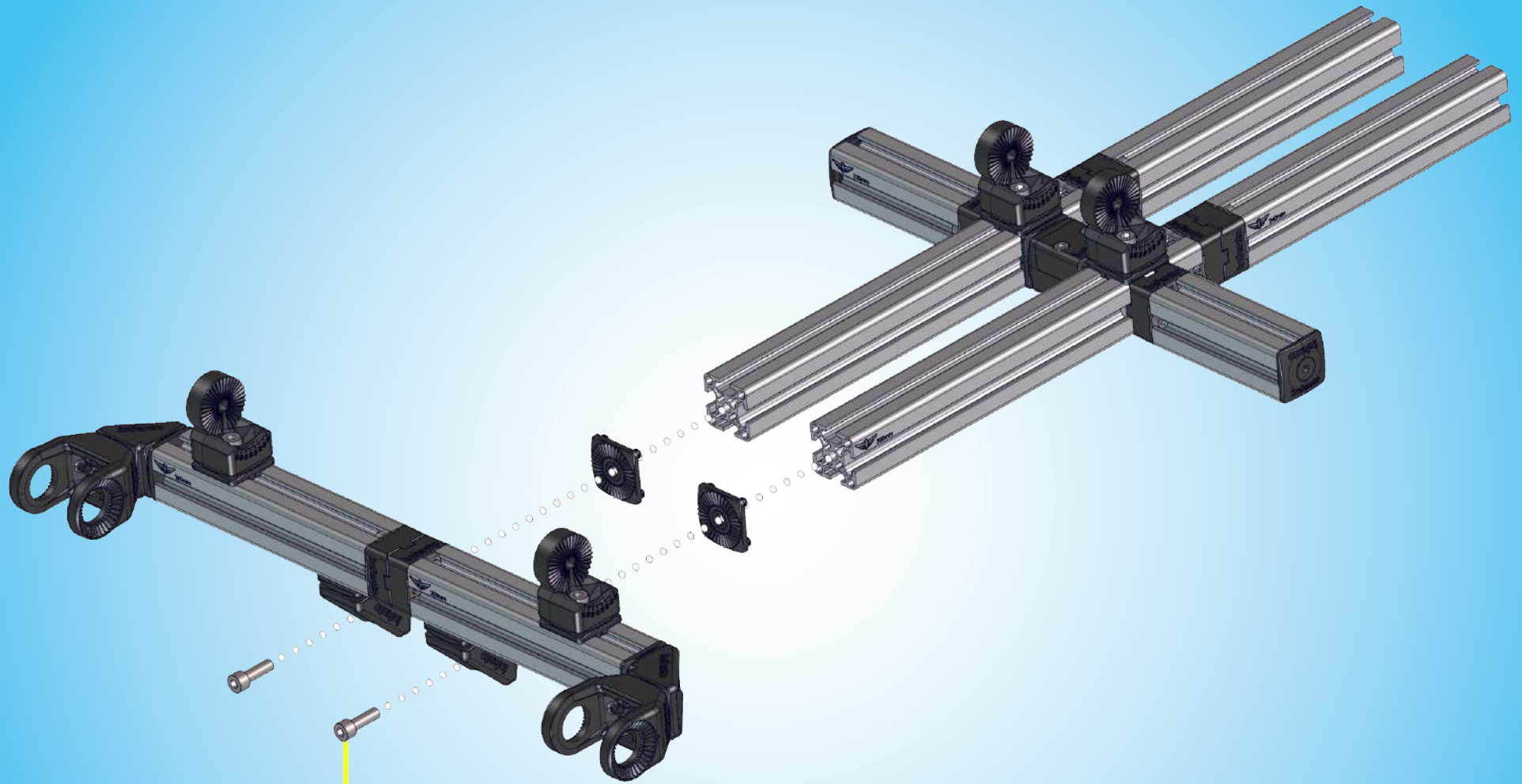

Bolt\_M8x25

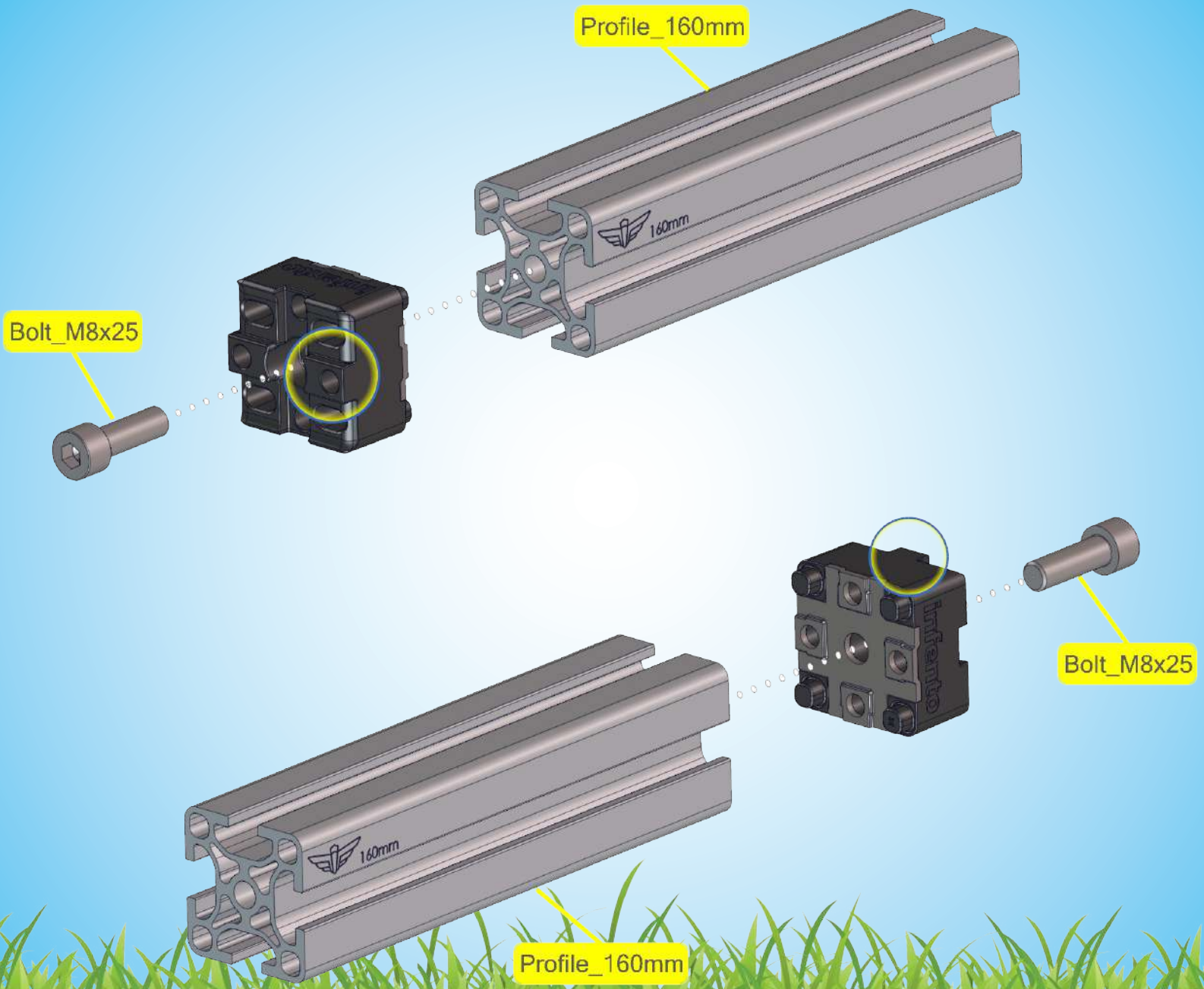

LockBolt\_M6x50

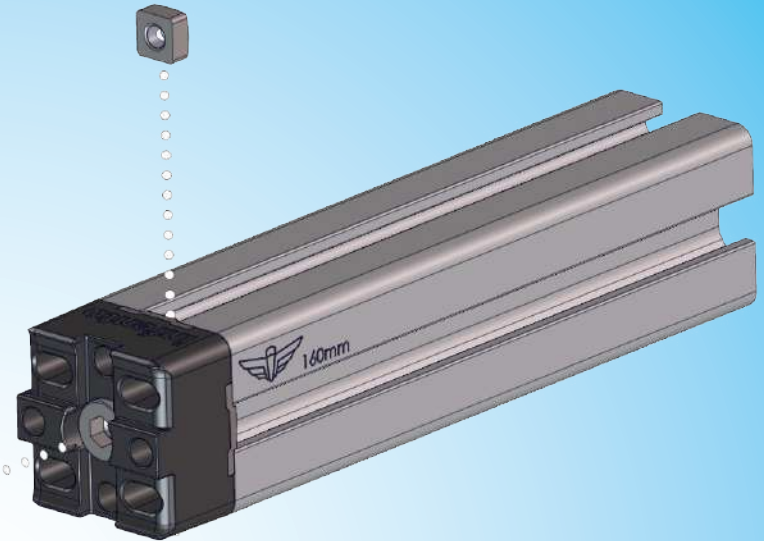
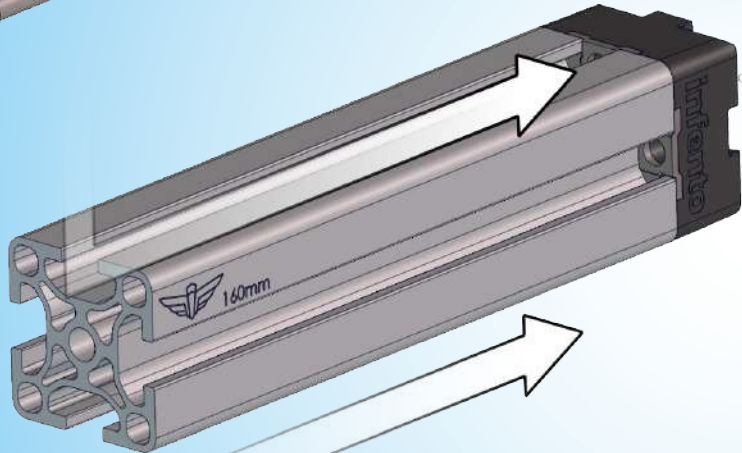
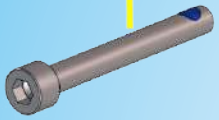

Square nut M6



Bolt\_M8x25

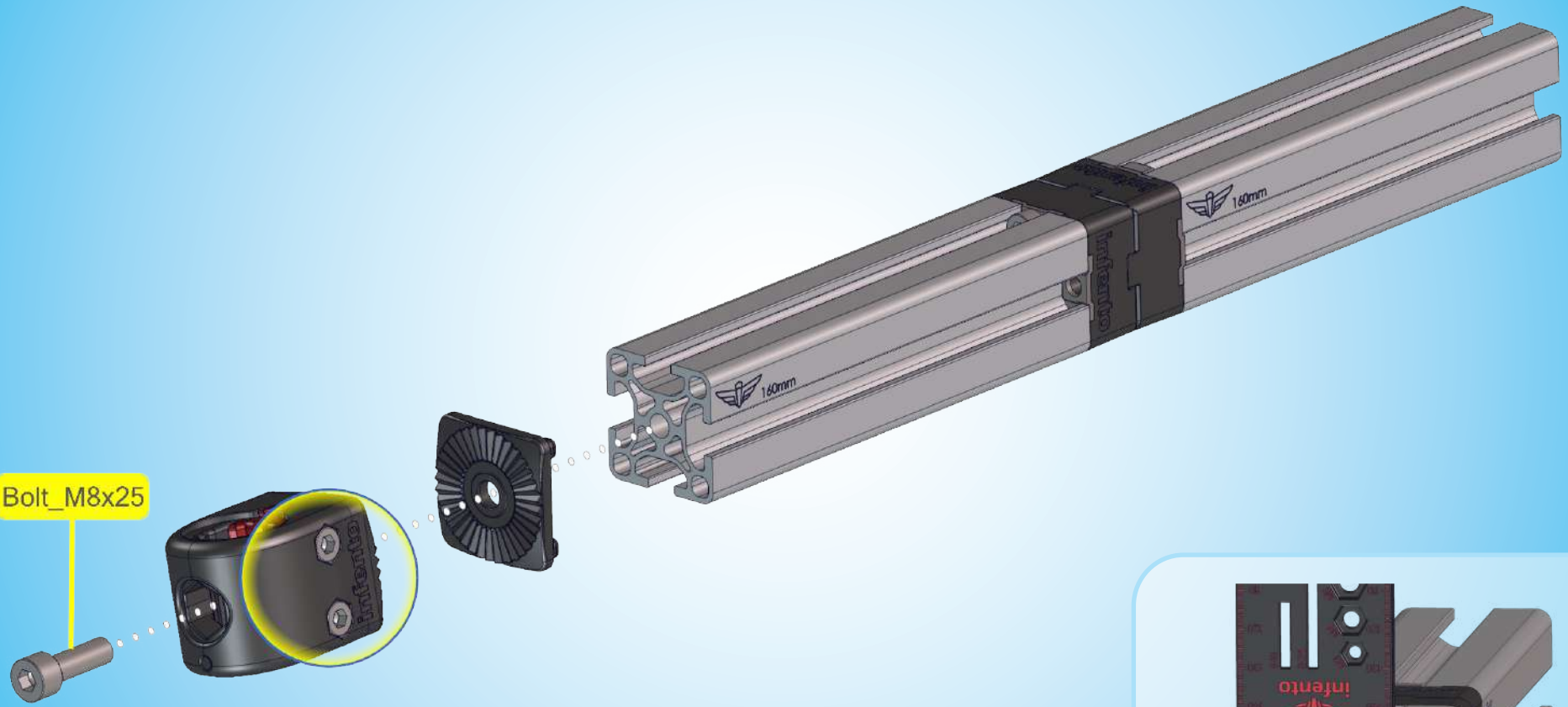



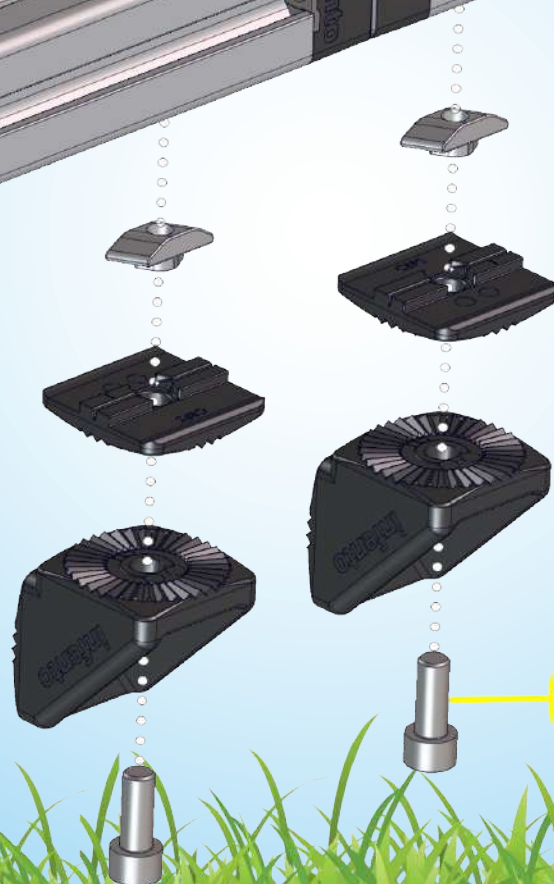
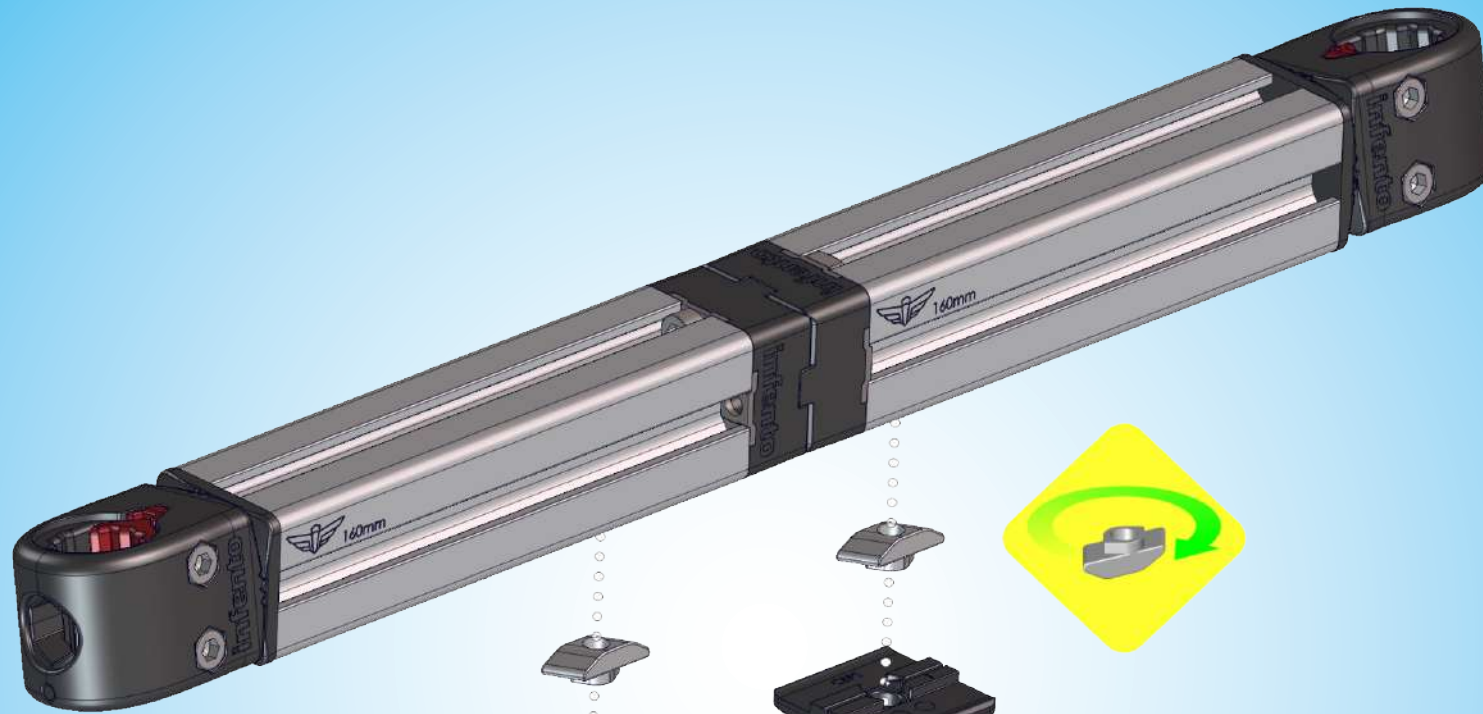

Bolt\_M8x20

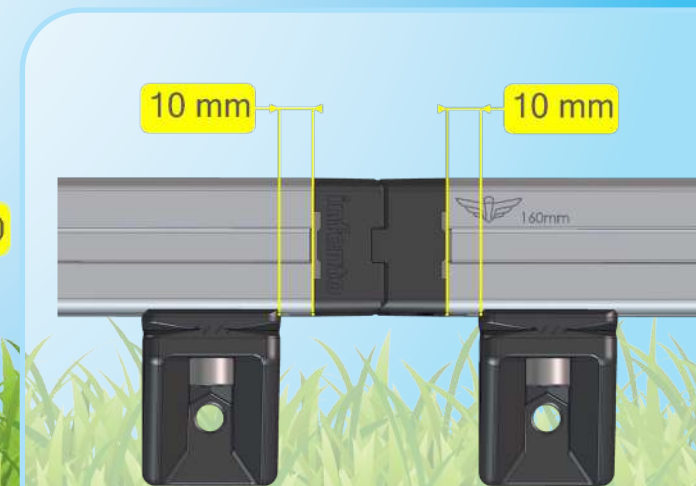

10 mm

10 mm

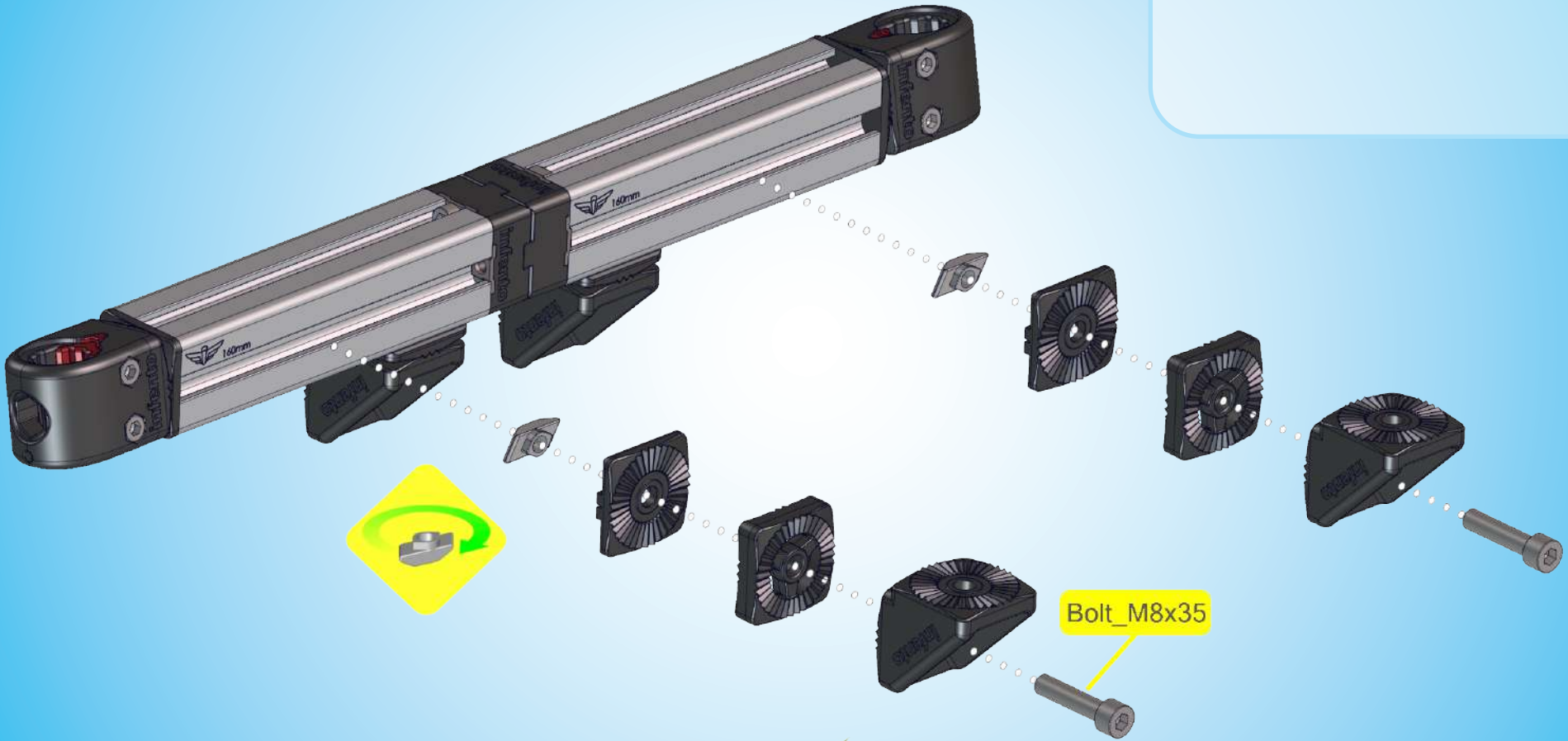
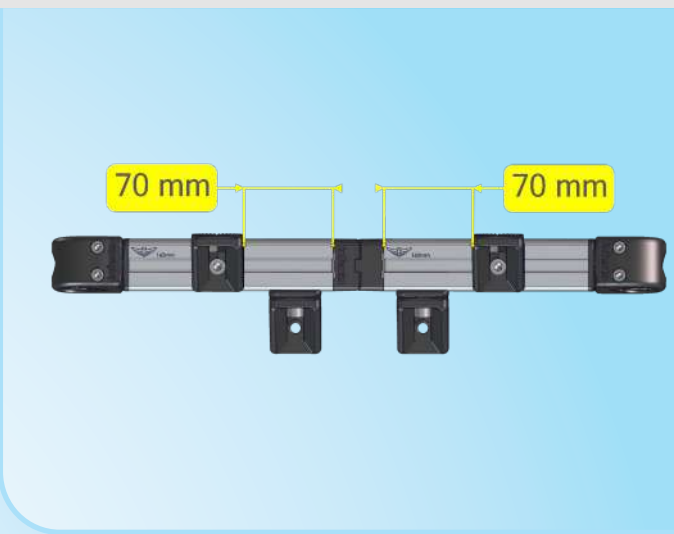



Bolt\_M8x25



2x

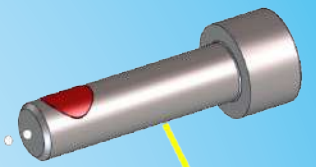
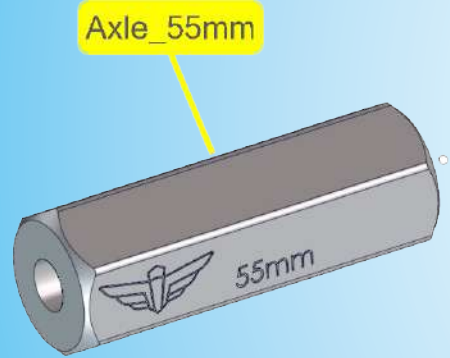

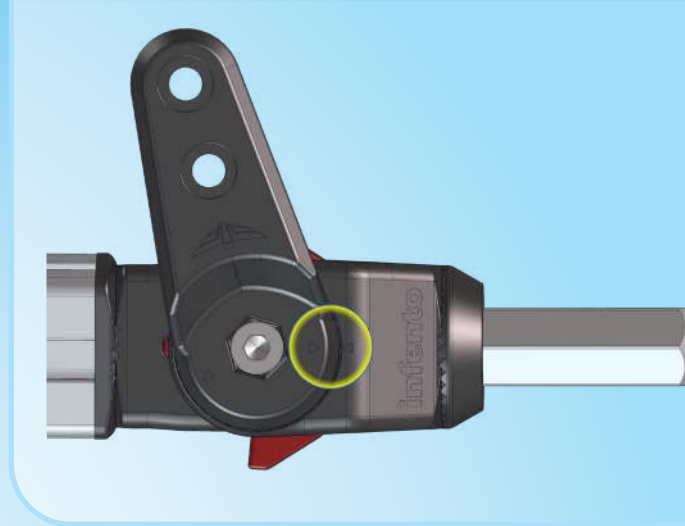
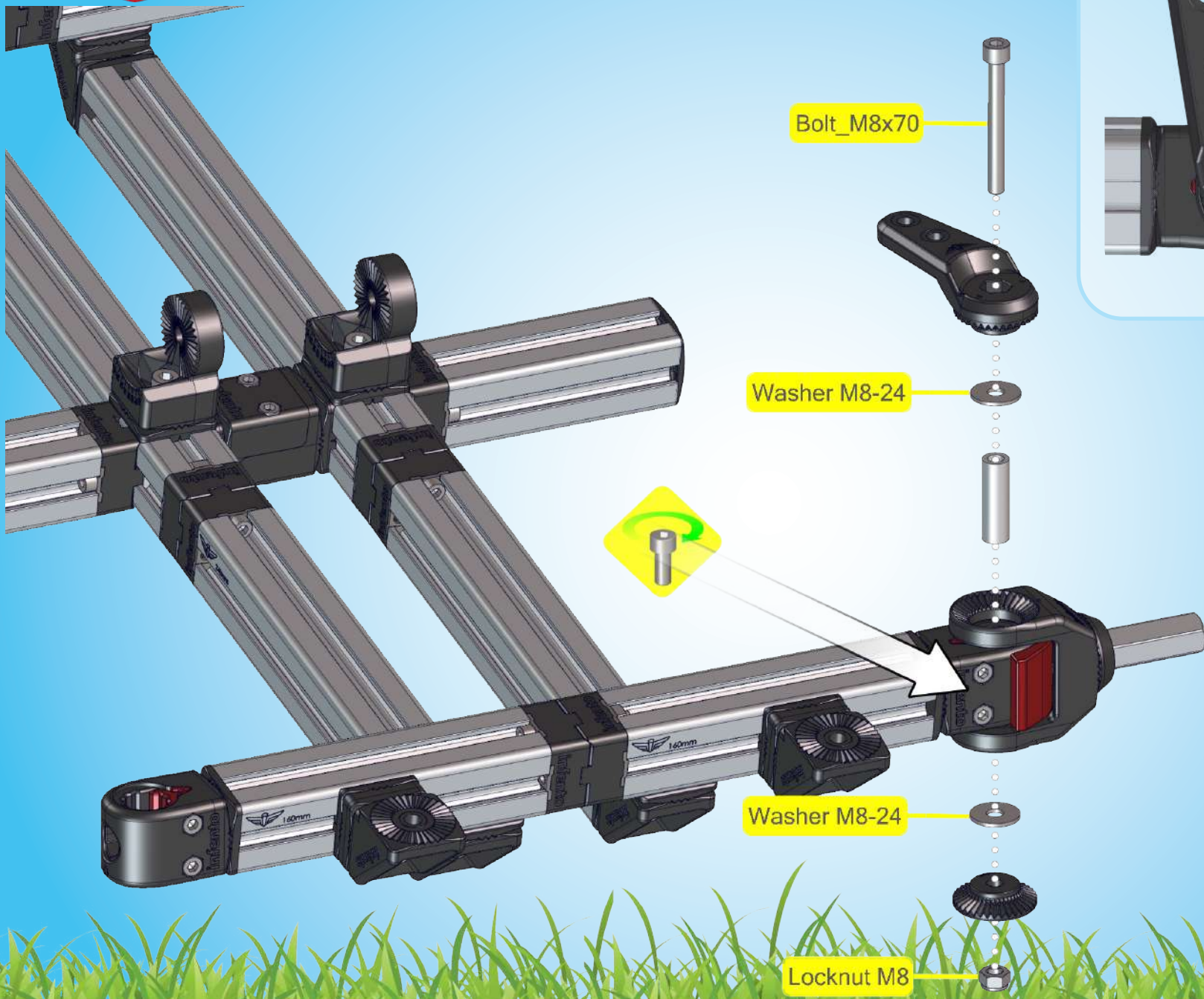

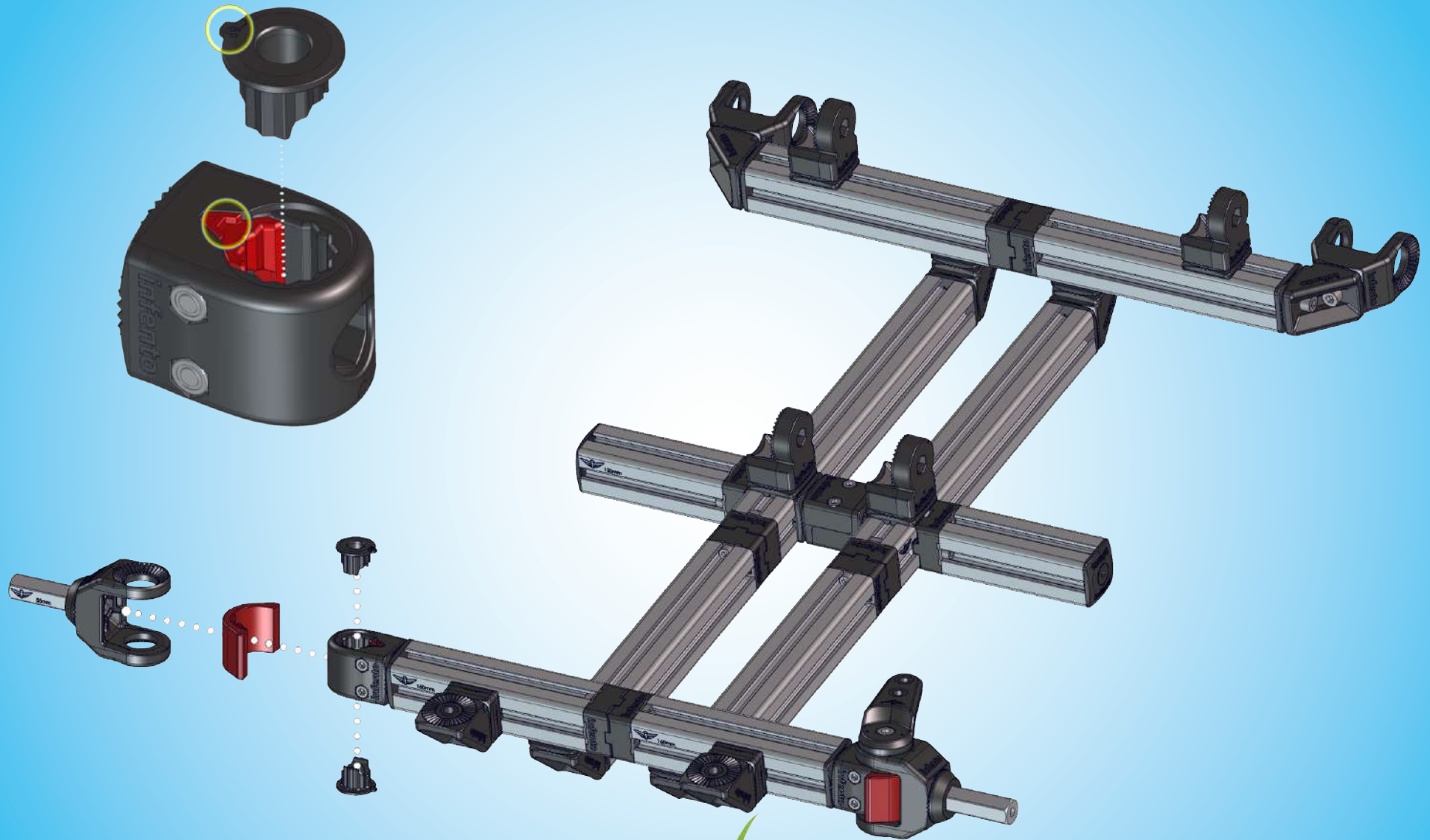

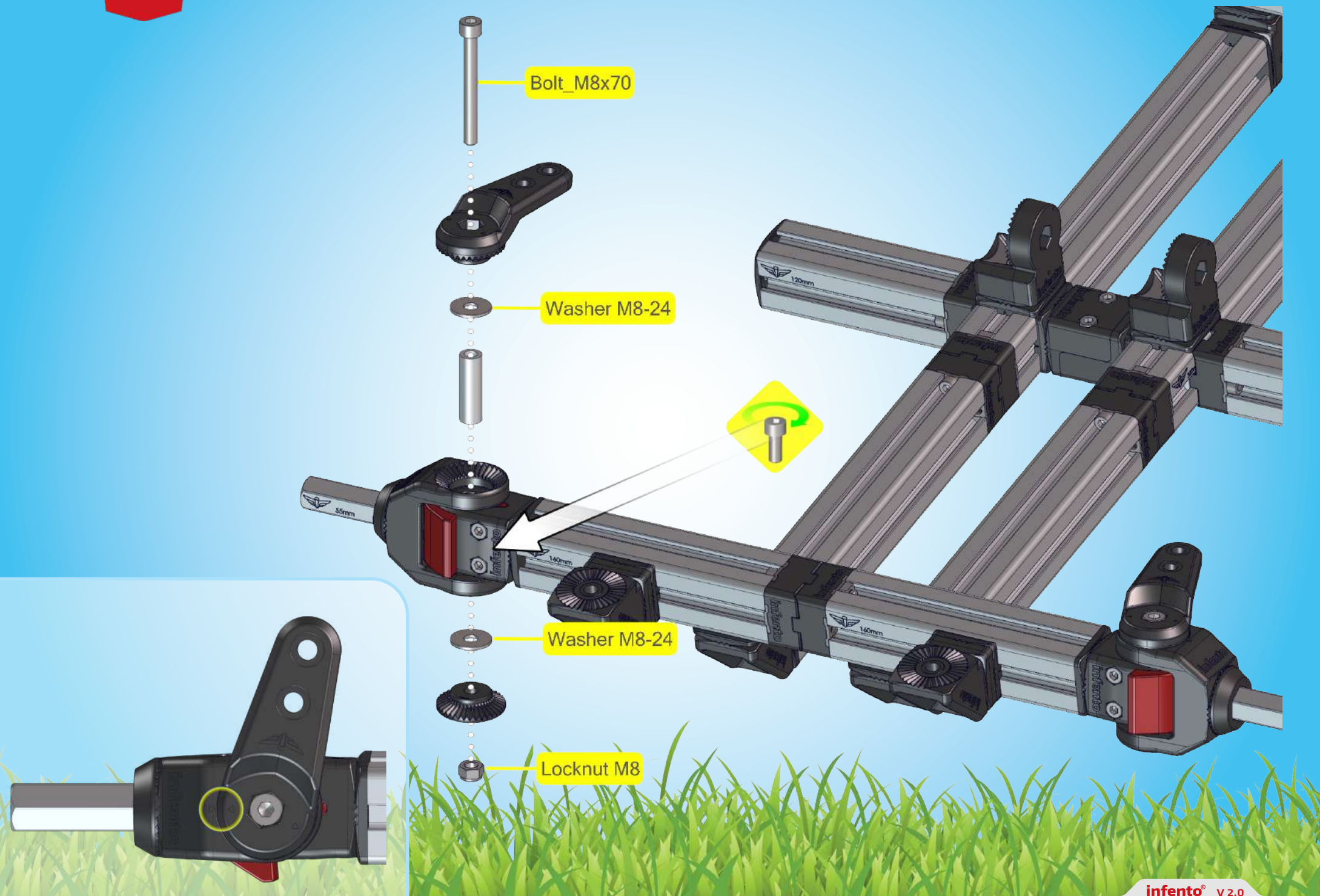

2x

LockBolt\_M6x50

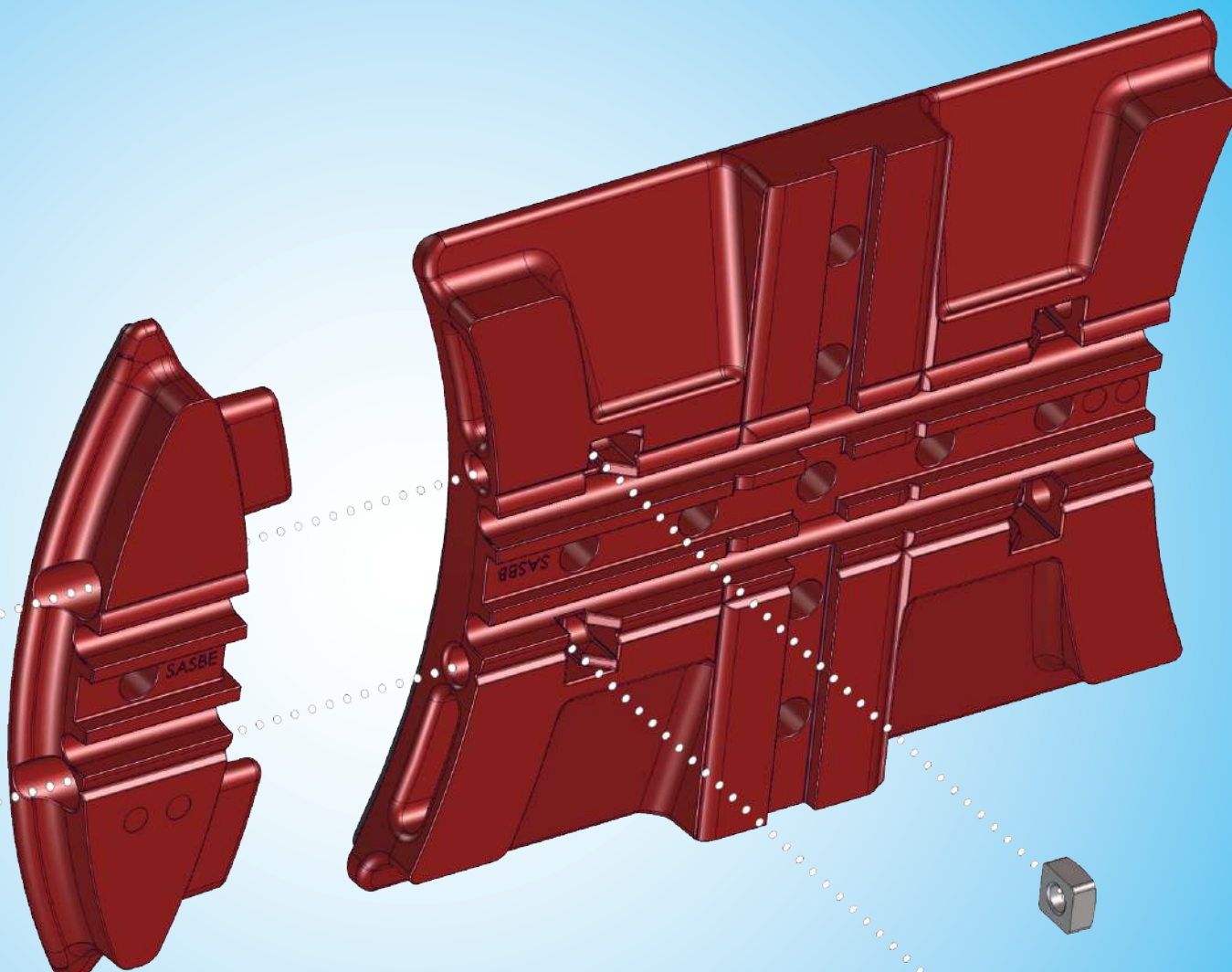
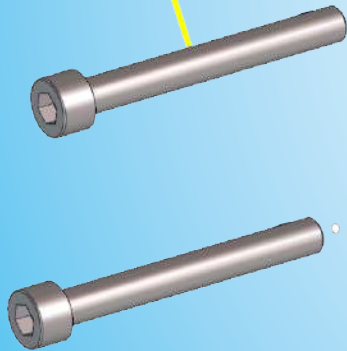

Square nut M6



Bolt\_M8x20

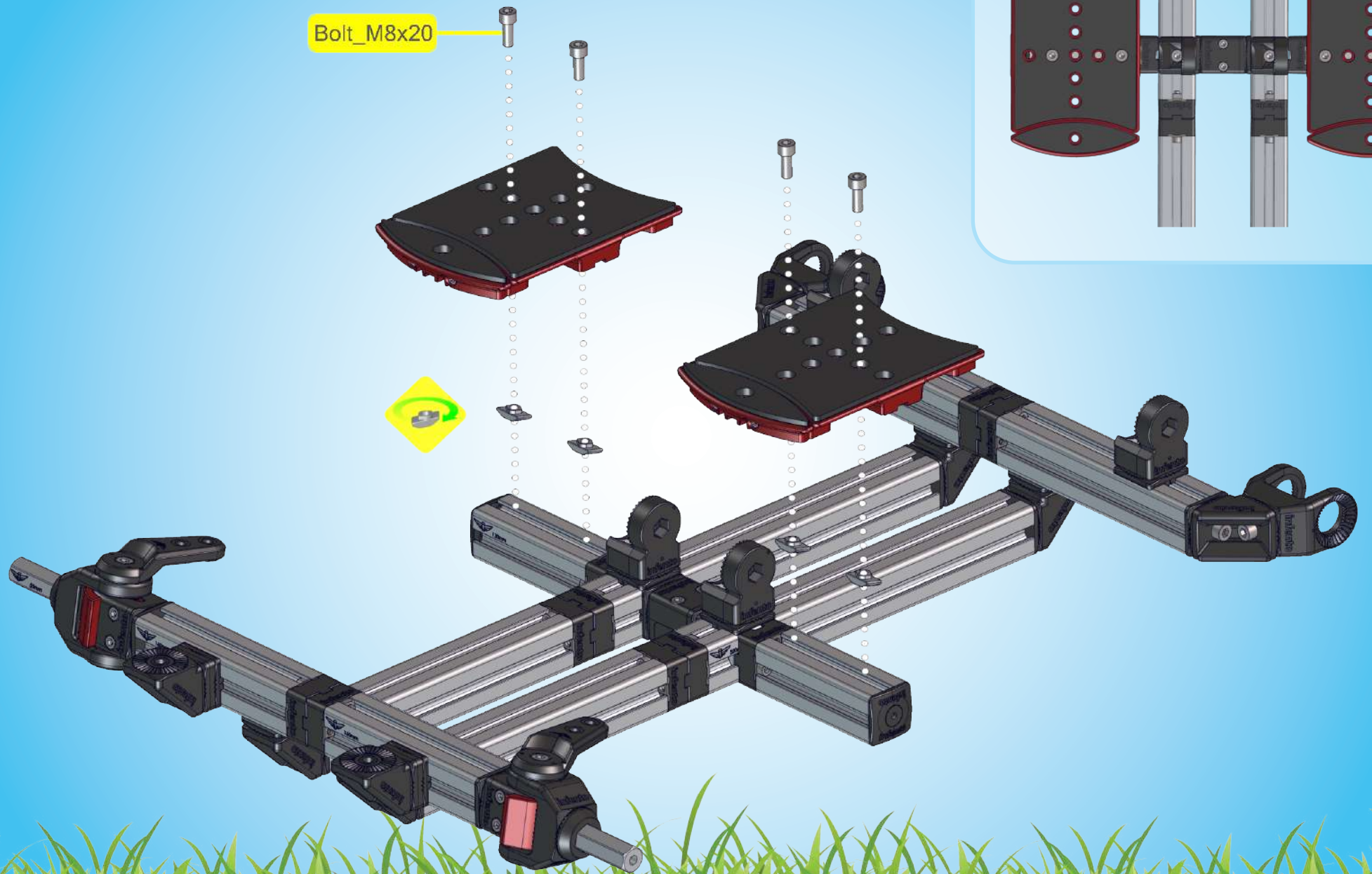

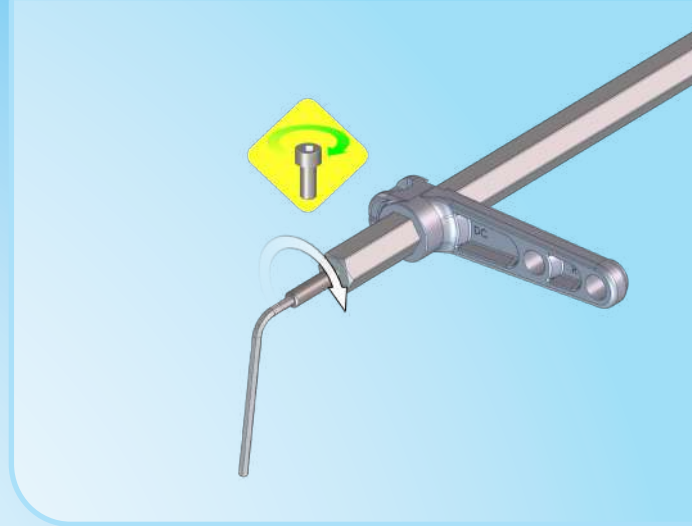

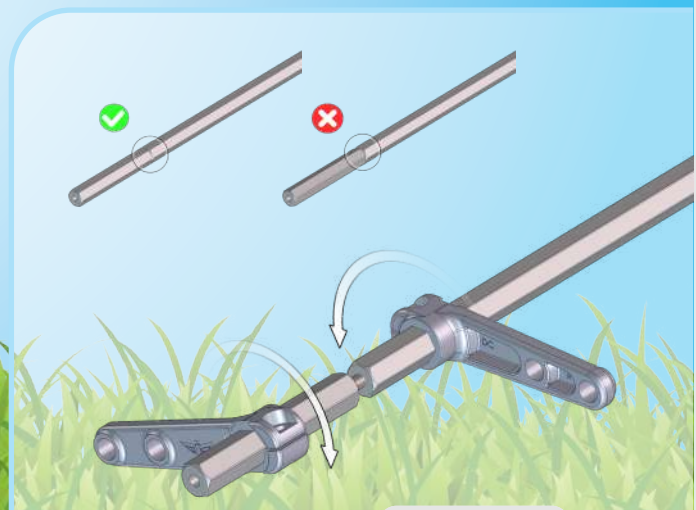

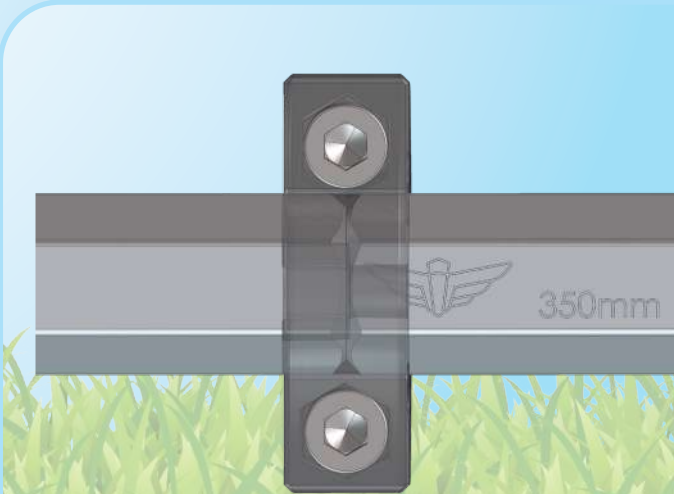
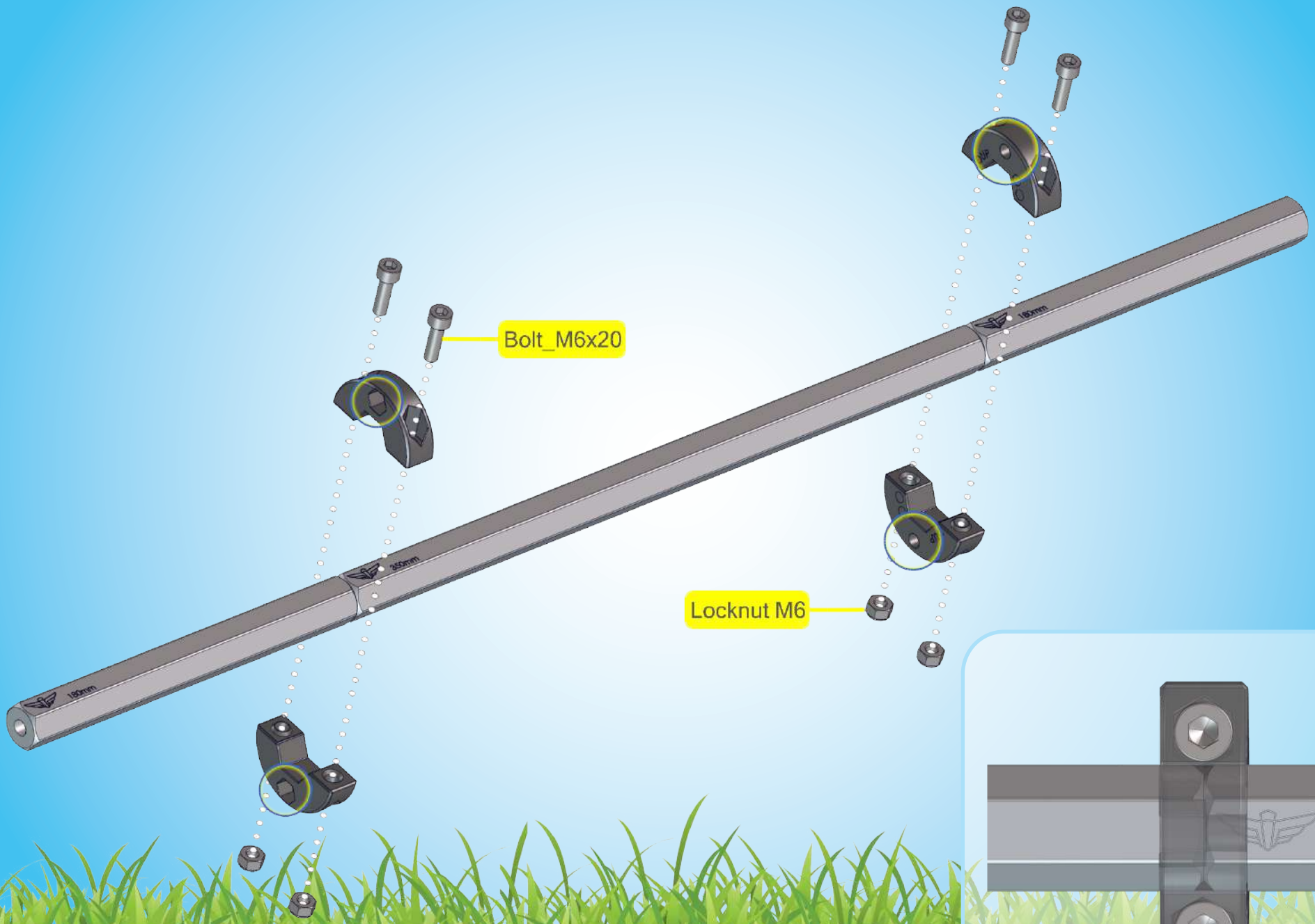



Locknut M8

Bolt\_M8x35

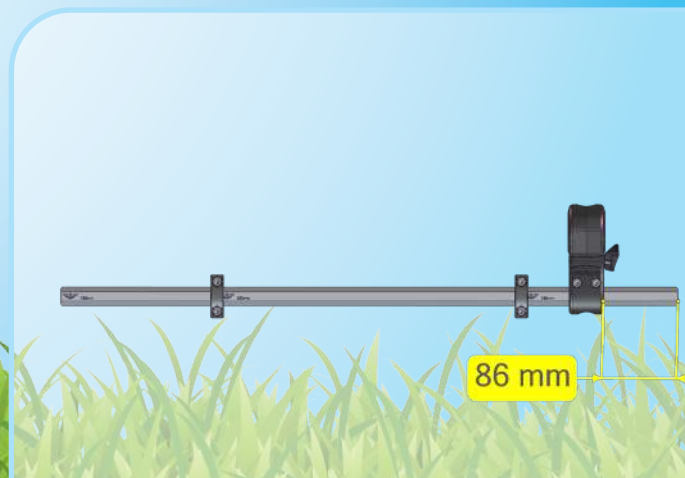

86 mm



Bolt\_M8x35

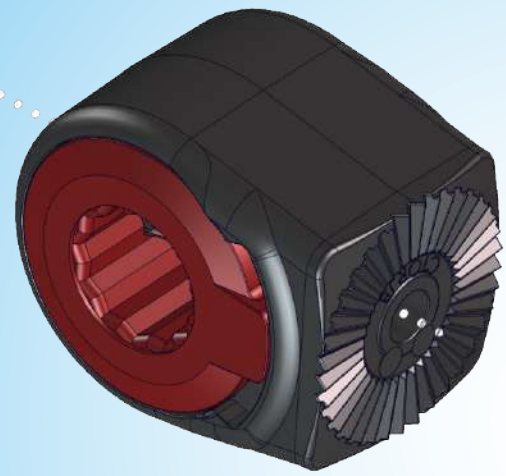

Locknut M8

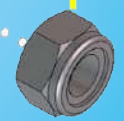

F.36

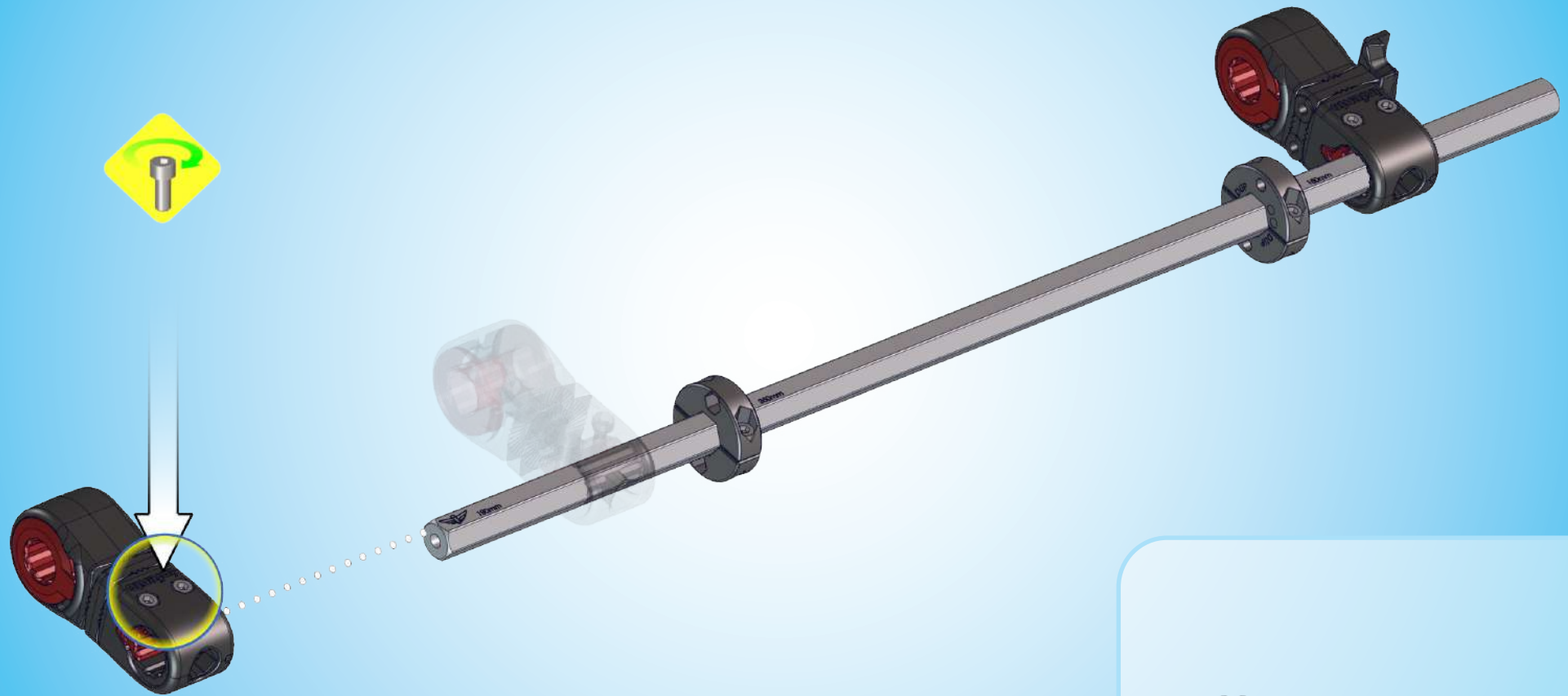

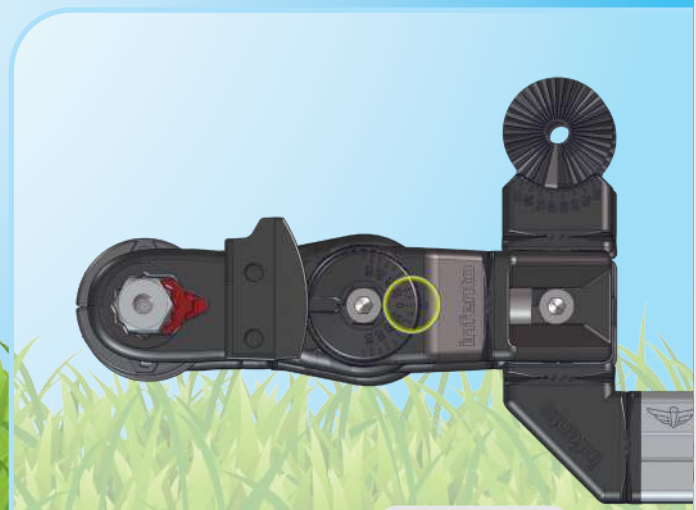
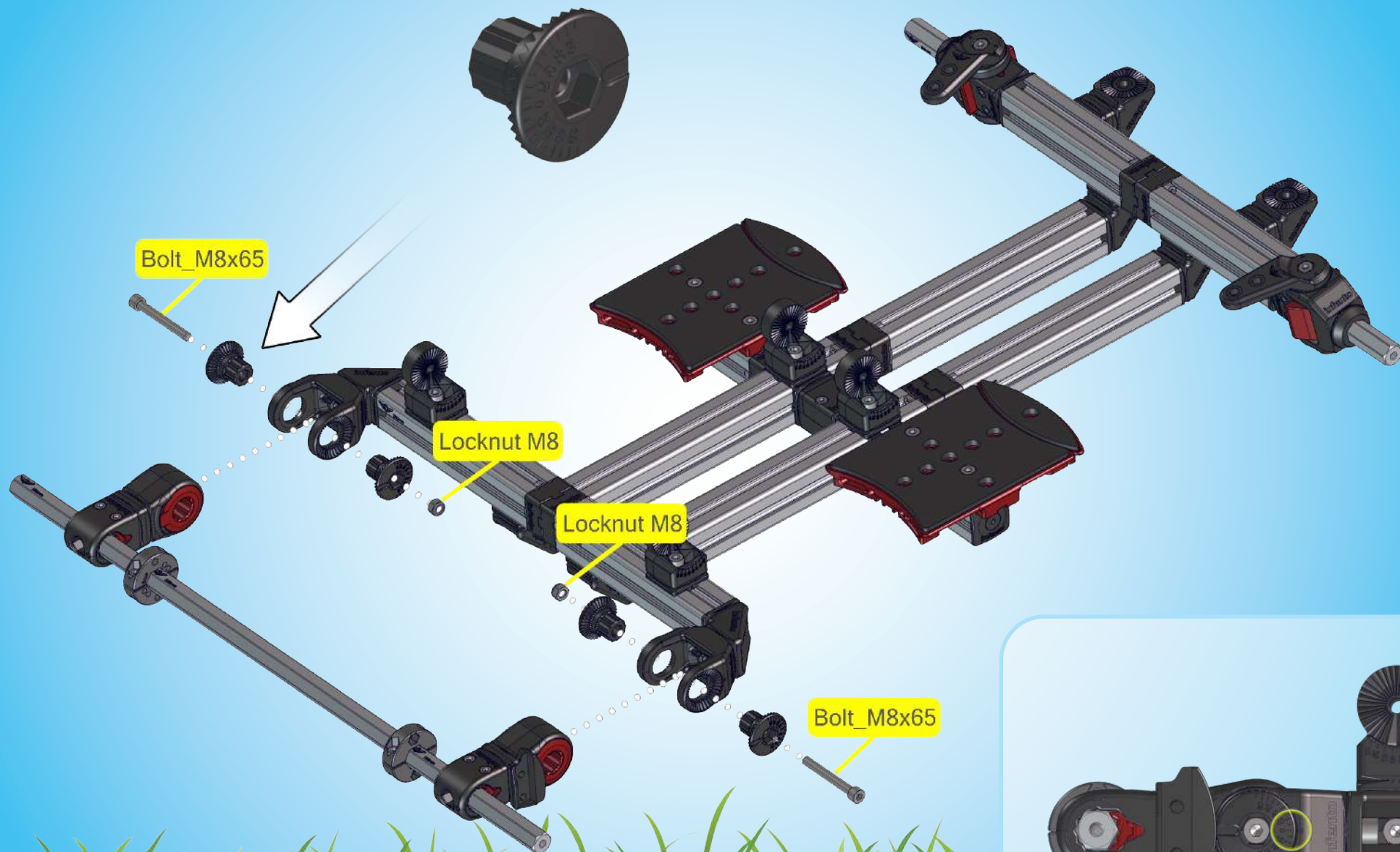



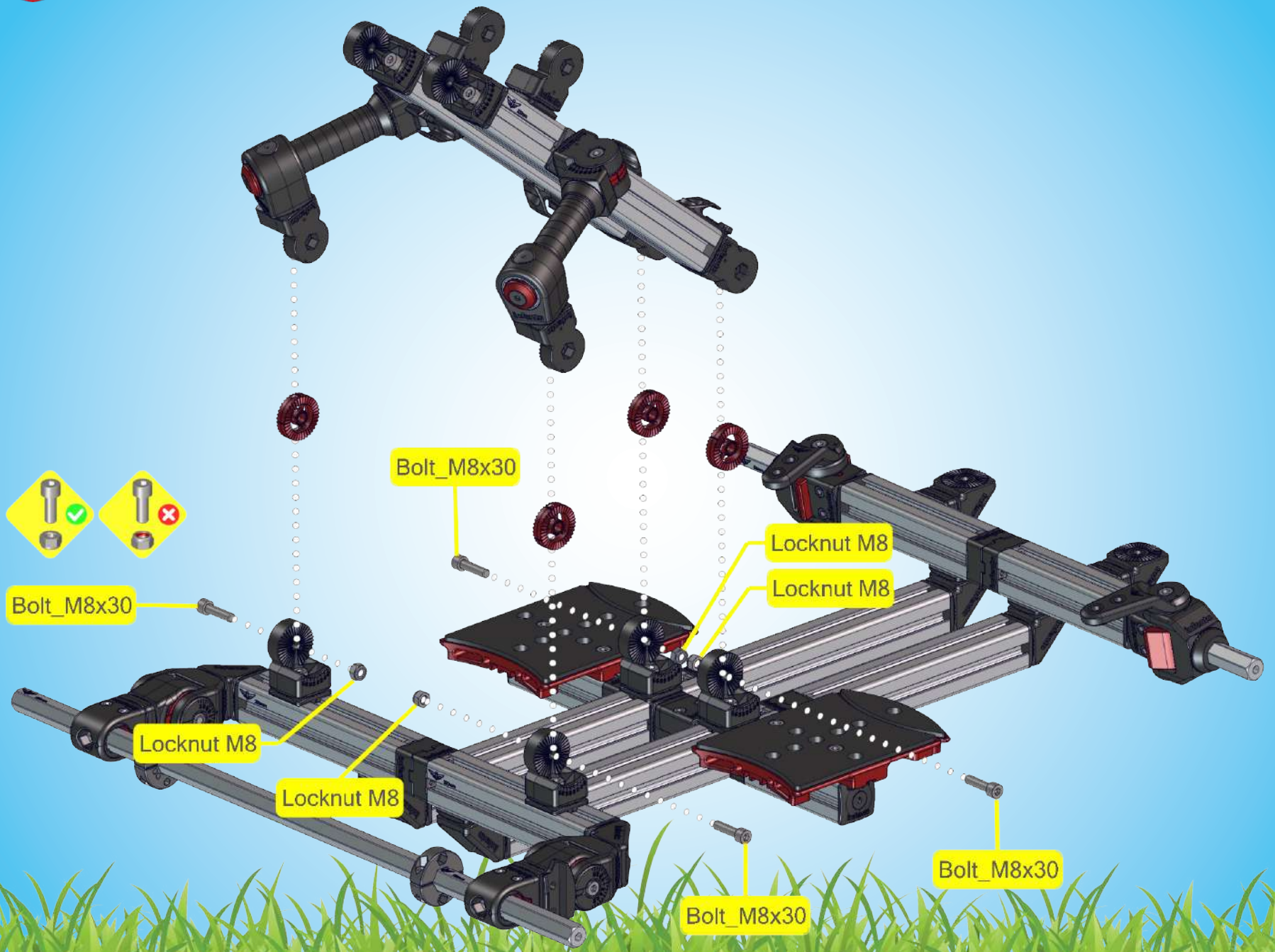

Bolt\_M8x12 Countersunk



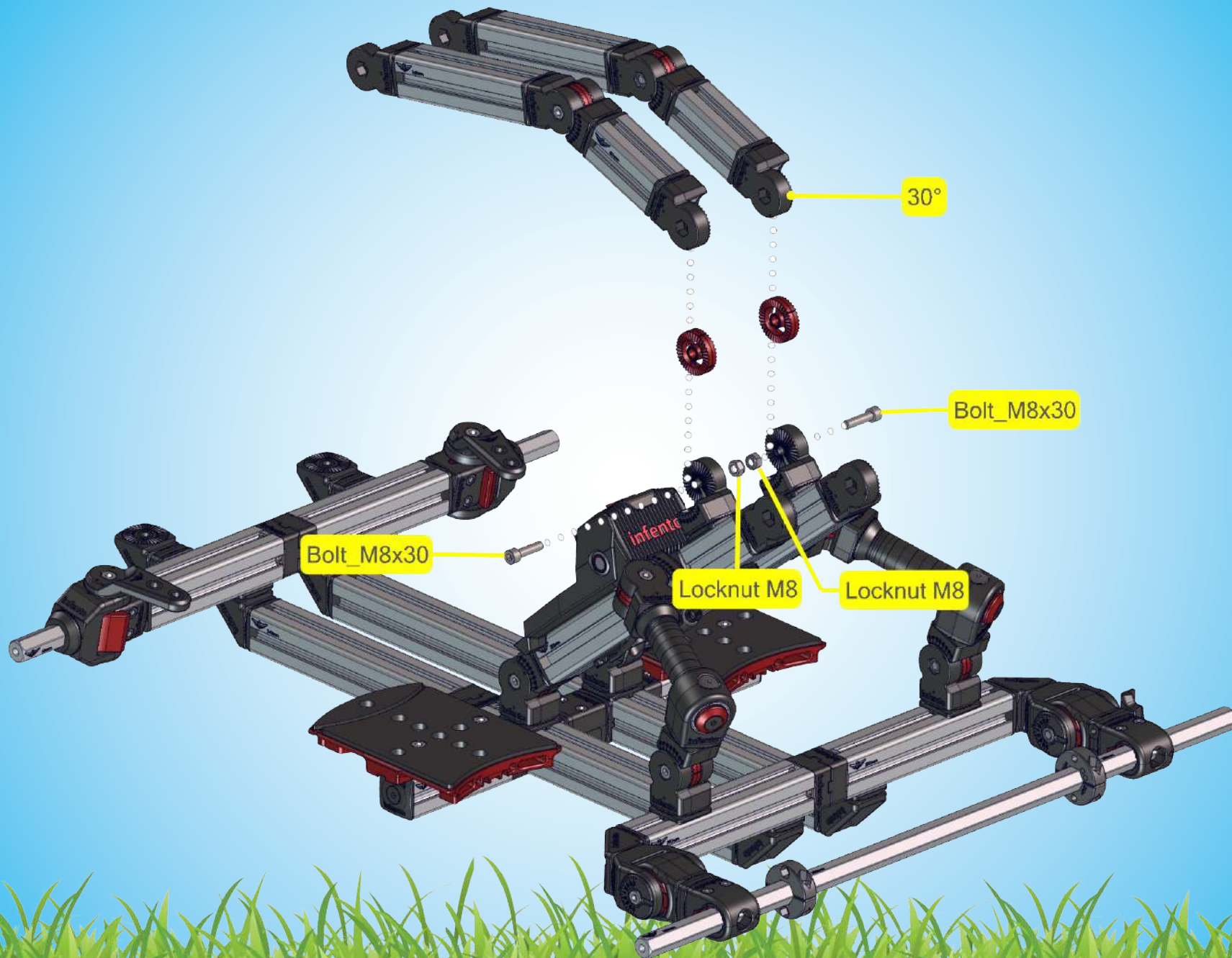





Bolt\_M8x60

Locknut M8





1

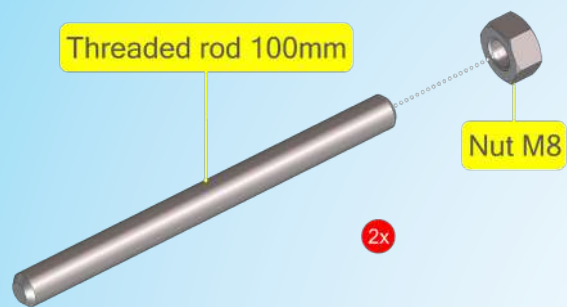

2

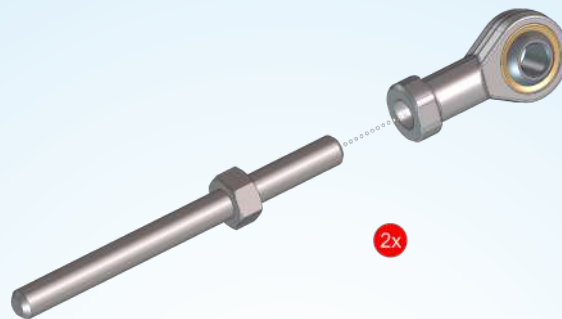

3

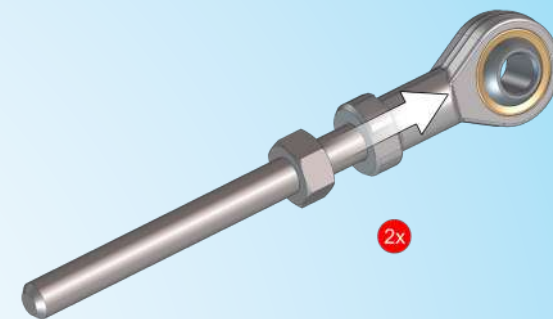

4

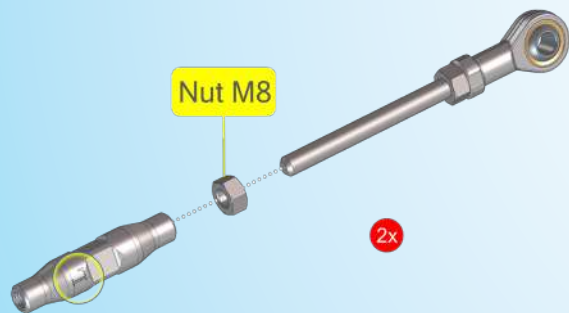

5

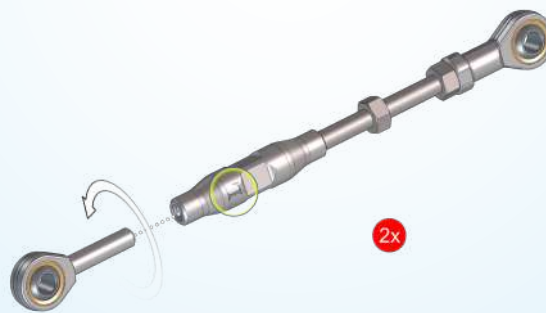

6

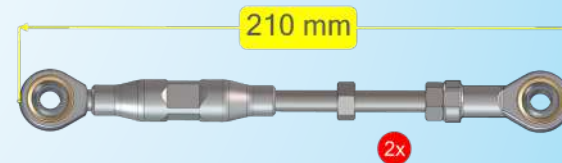

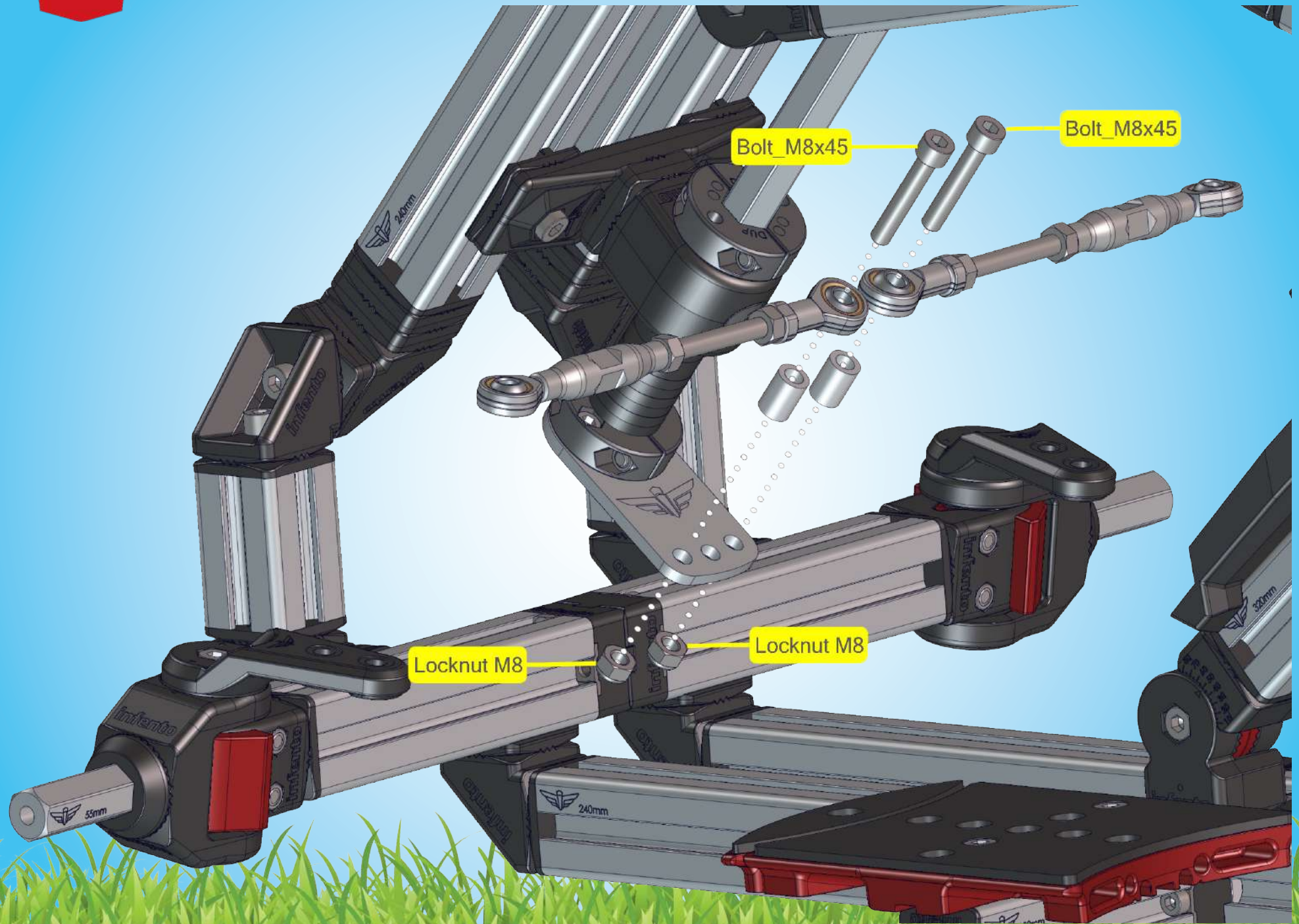

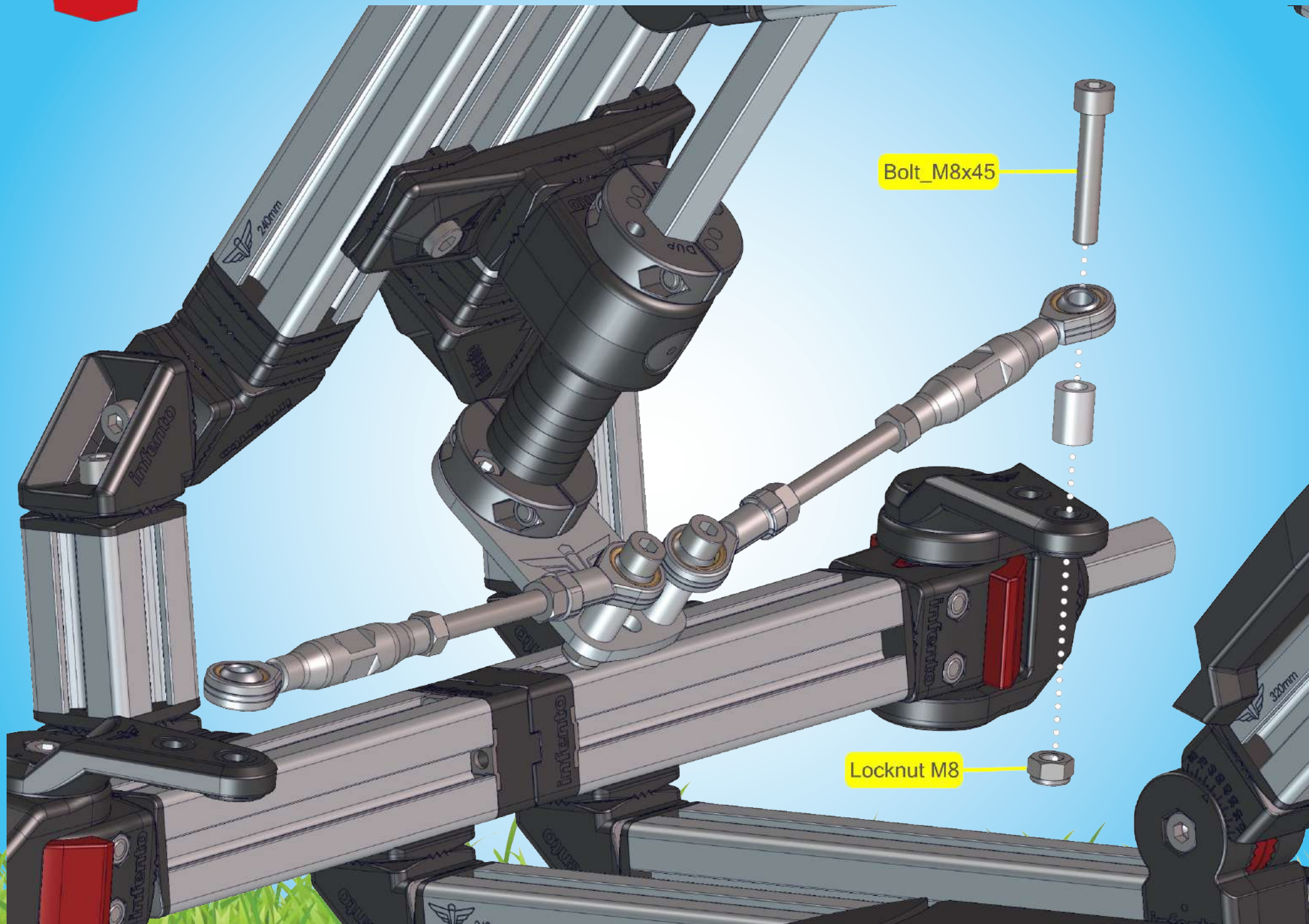

Bolt\_M8x45

Locknut M8

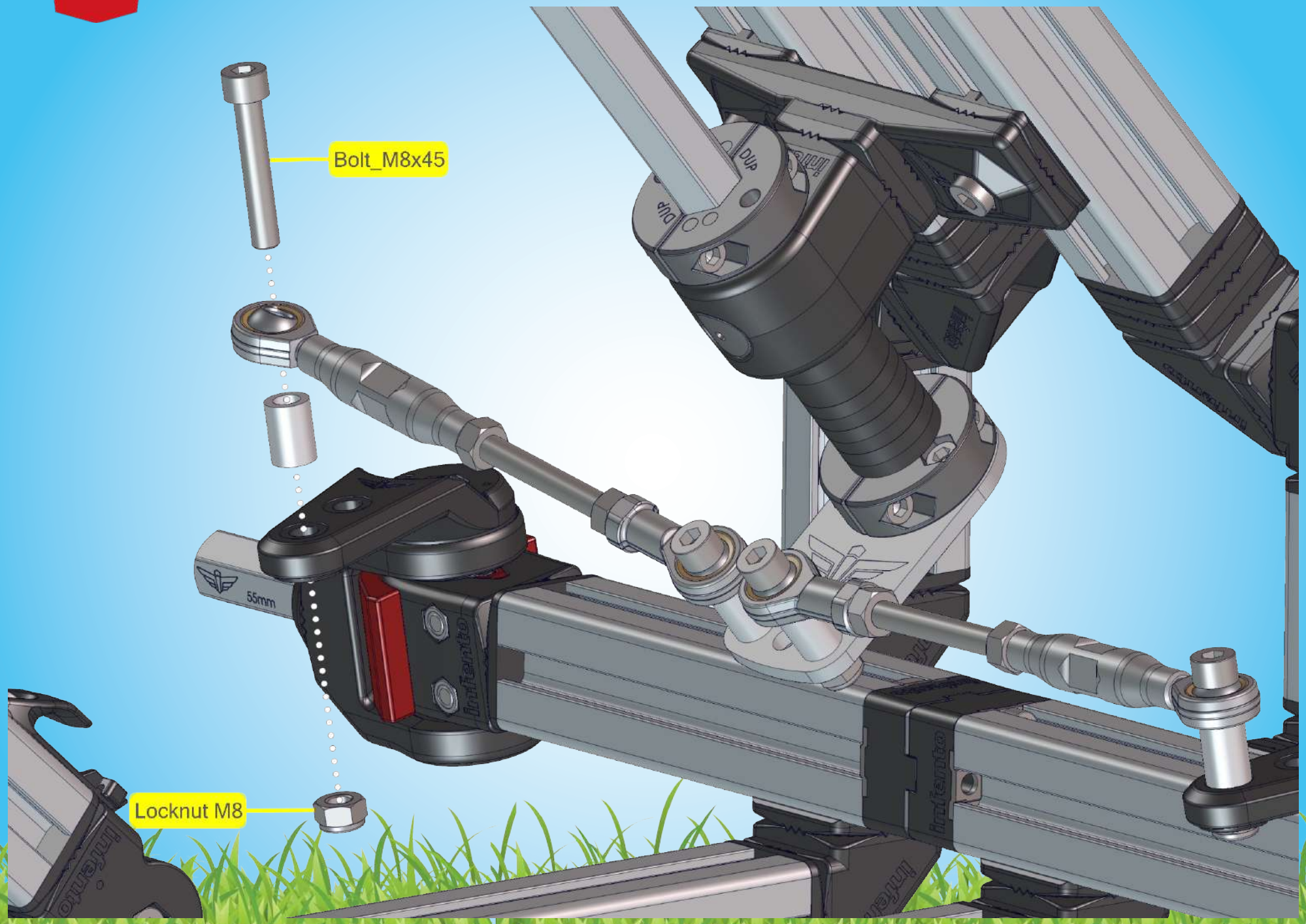

Bolt\_M8x45

Locknut M8

1

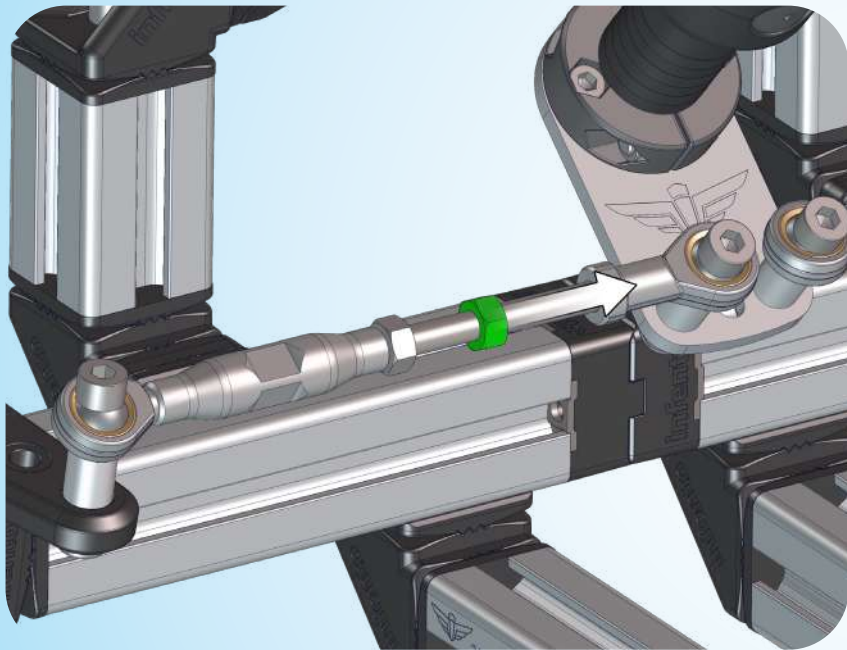

2

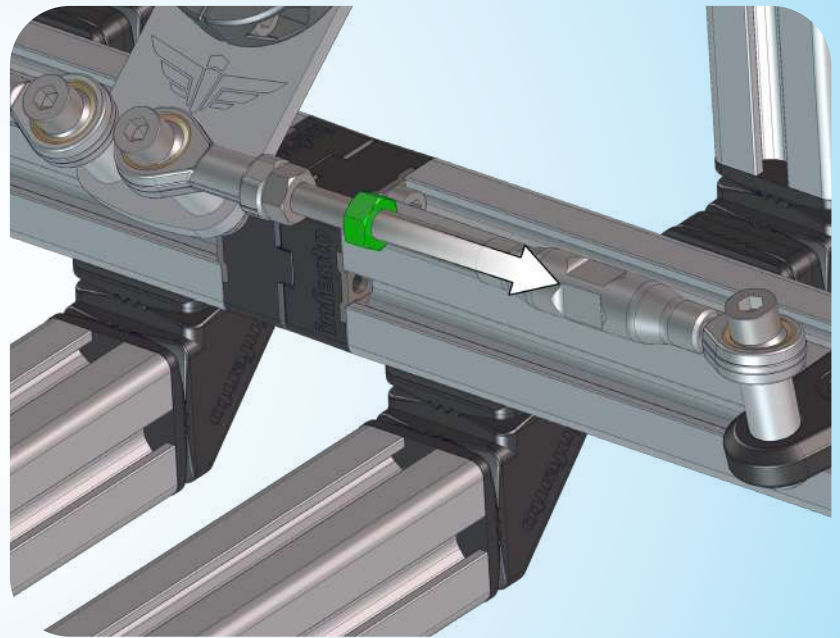

1



2

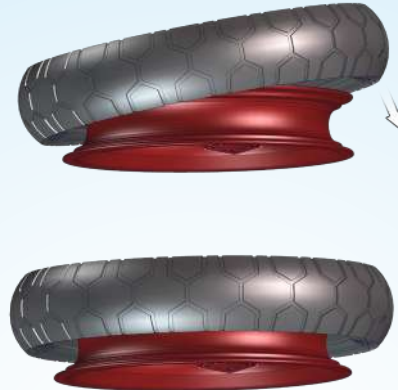

3



4



5



6



1

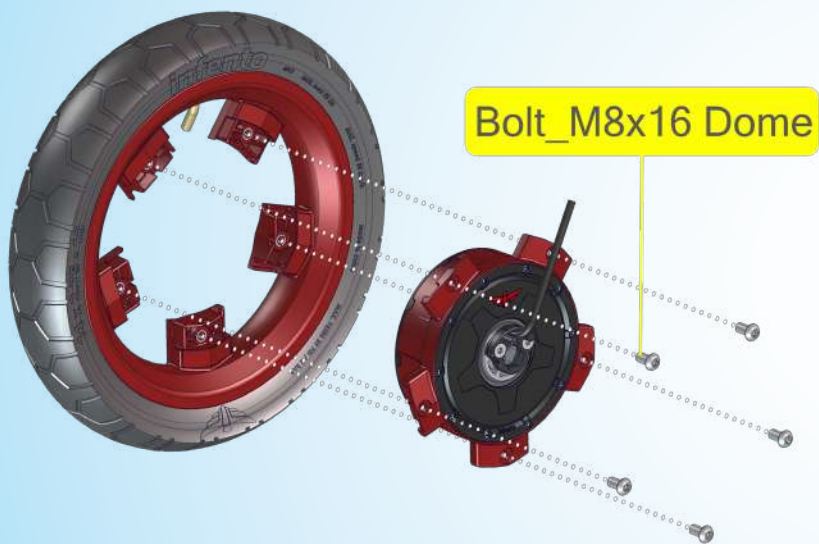

2



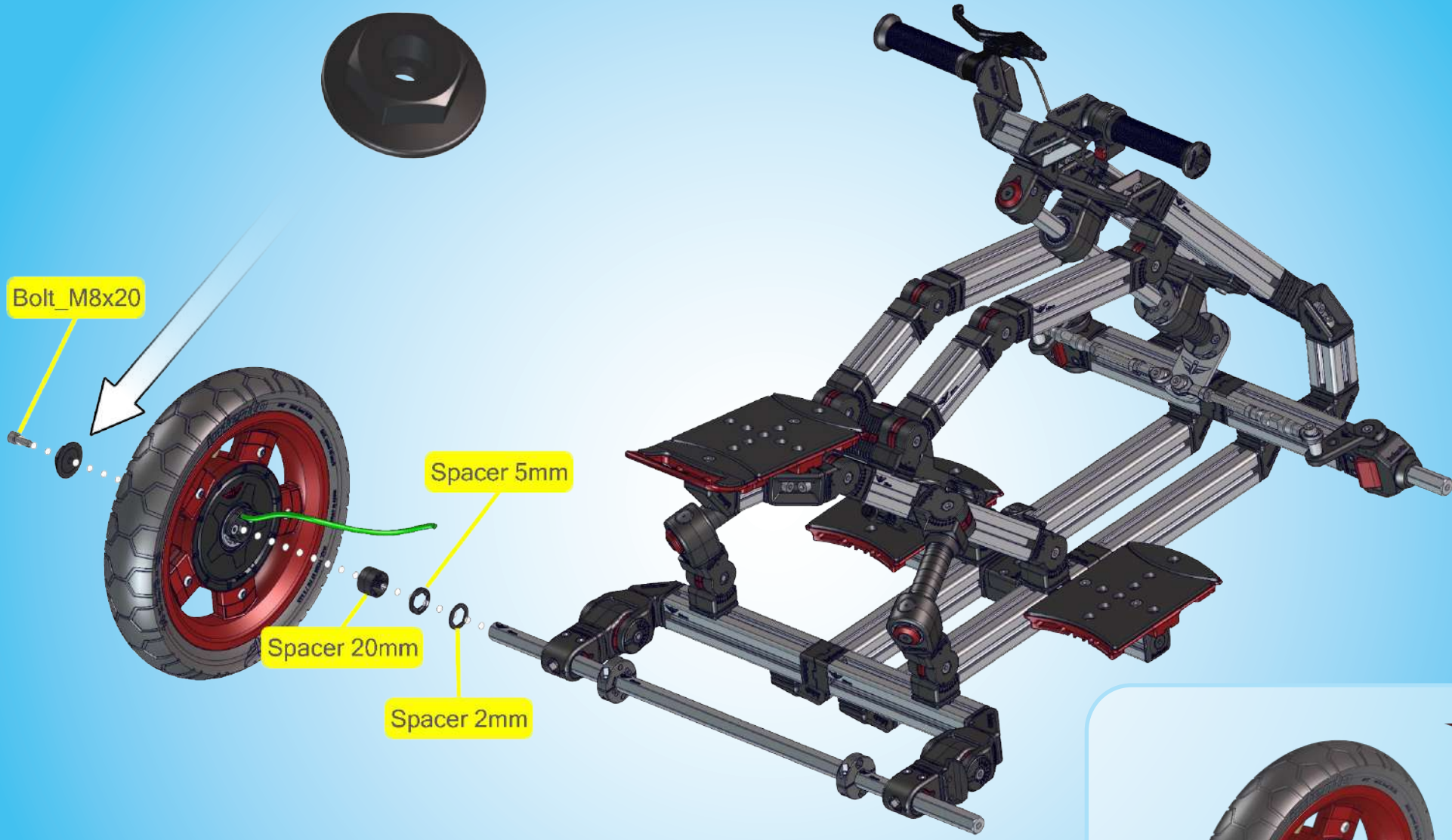

1



2

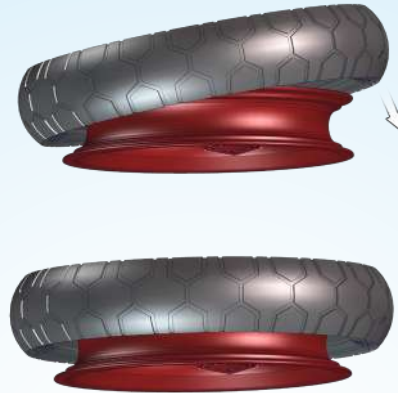

3



4



5



6



1



2

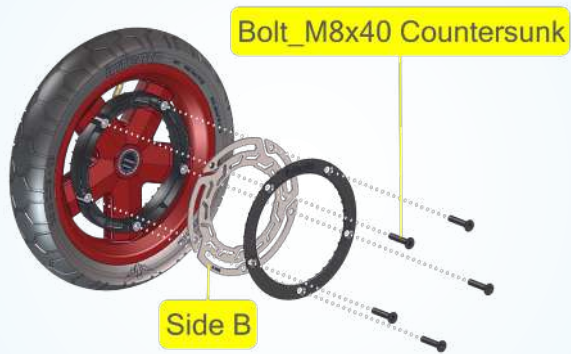

3





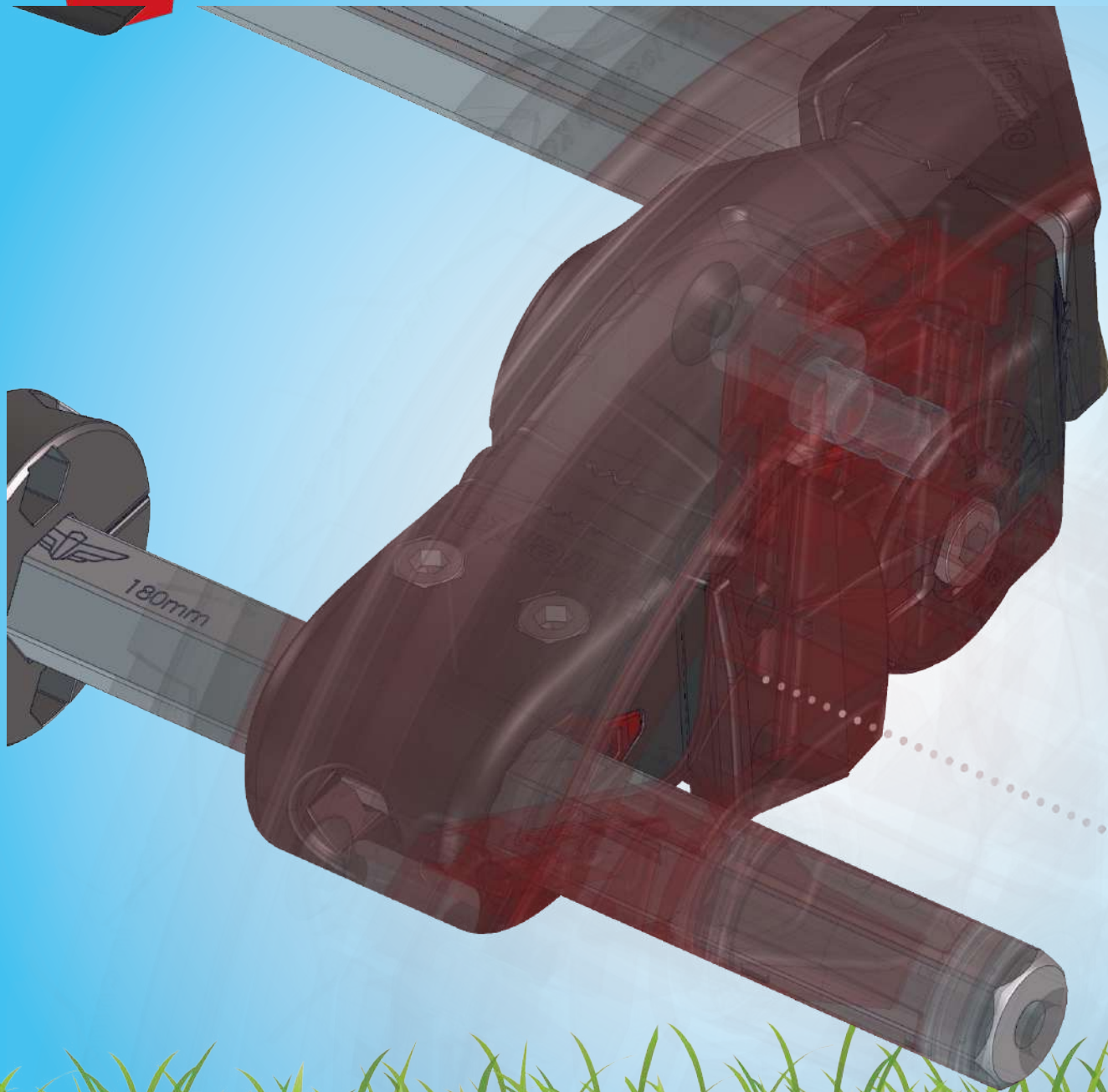

Caliper spacer



1

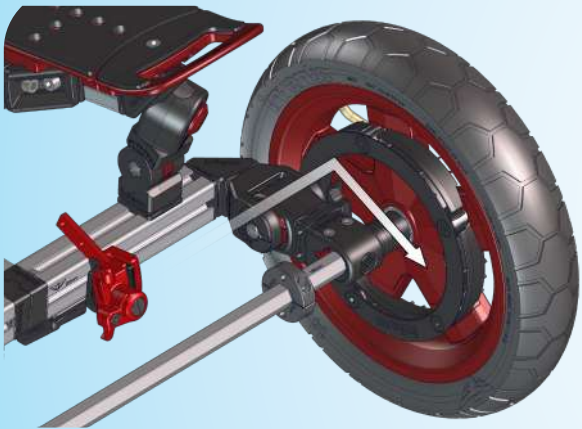

2

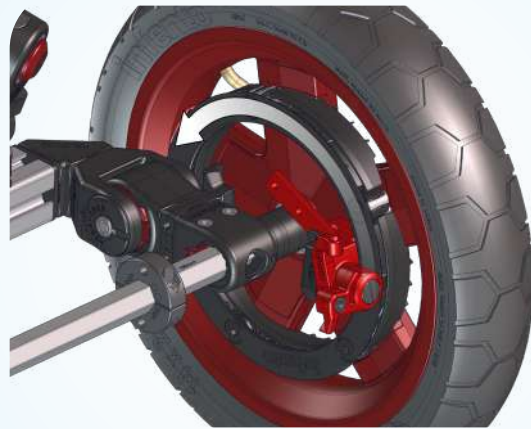

3



1



2

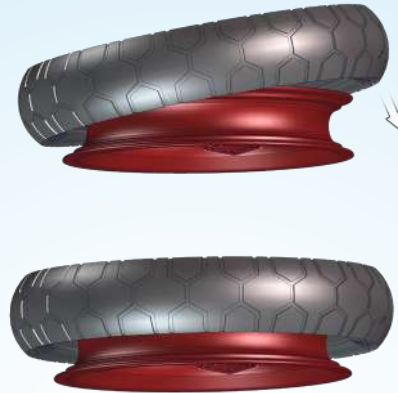

3



4



5



6



1

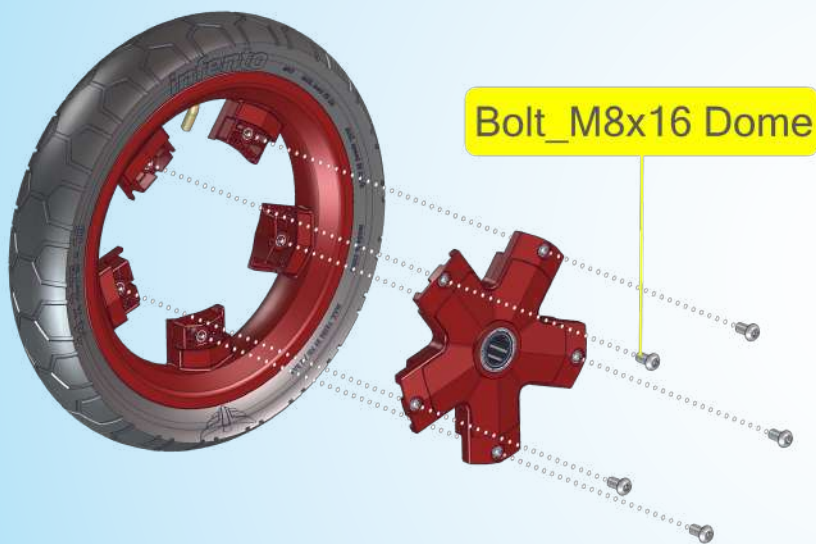

2





Bolt\_M8x20

Brake / throttle cable







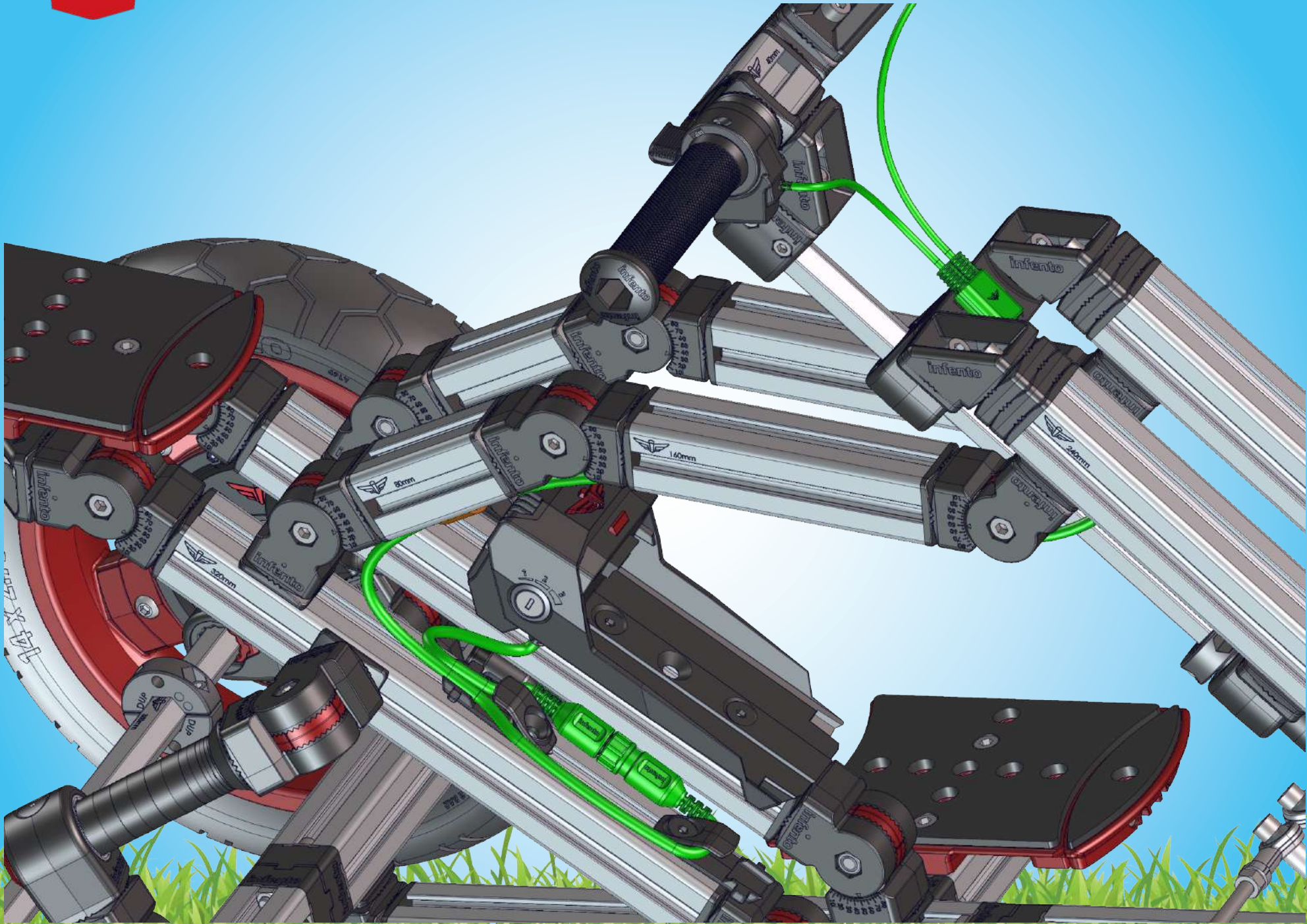

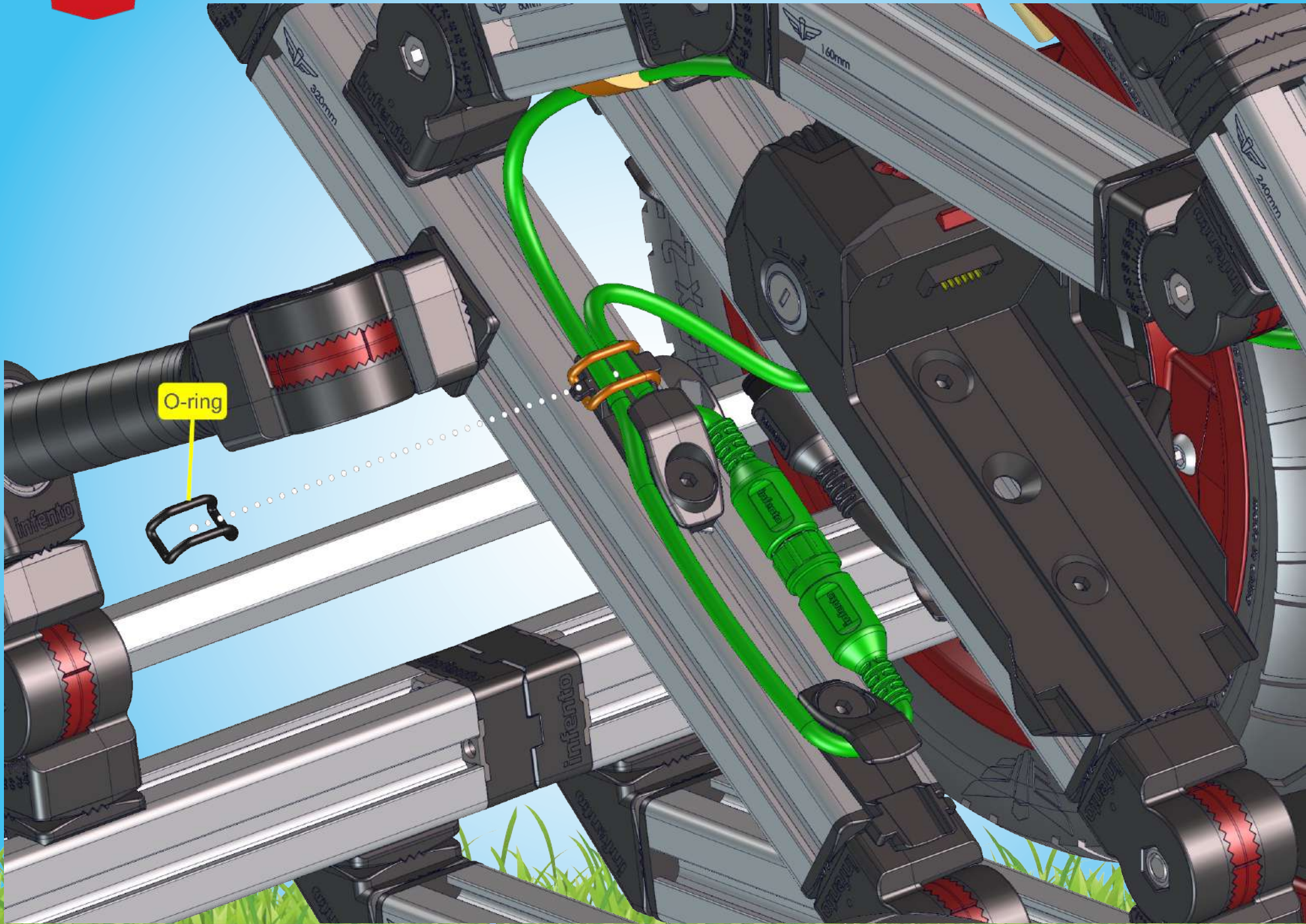



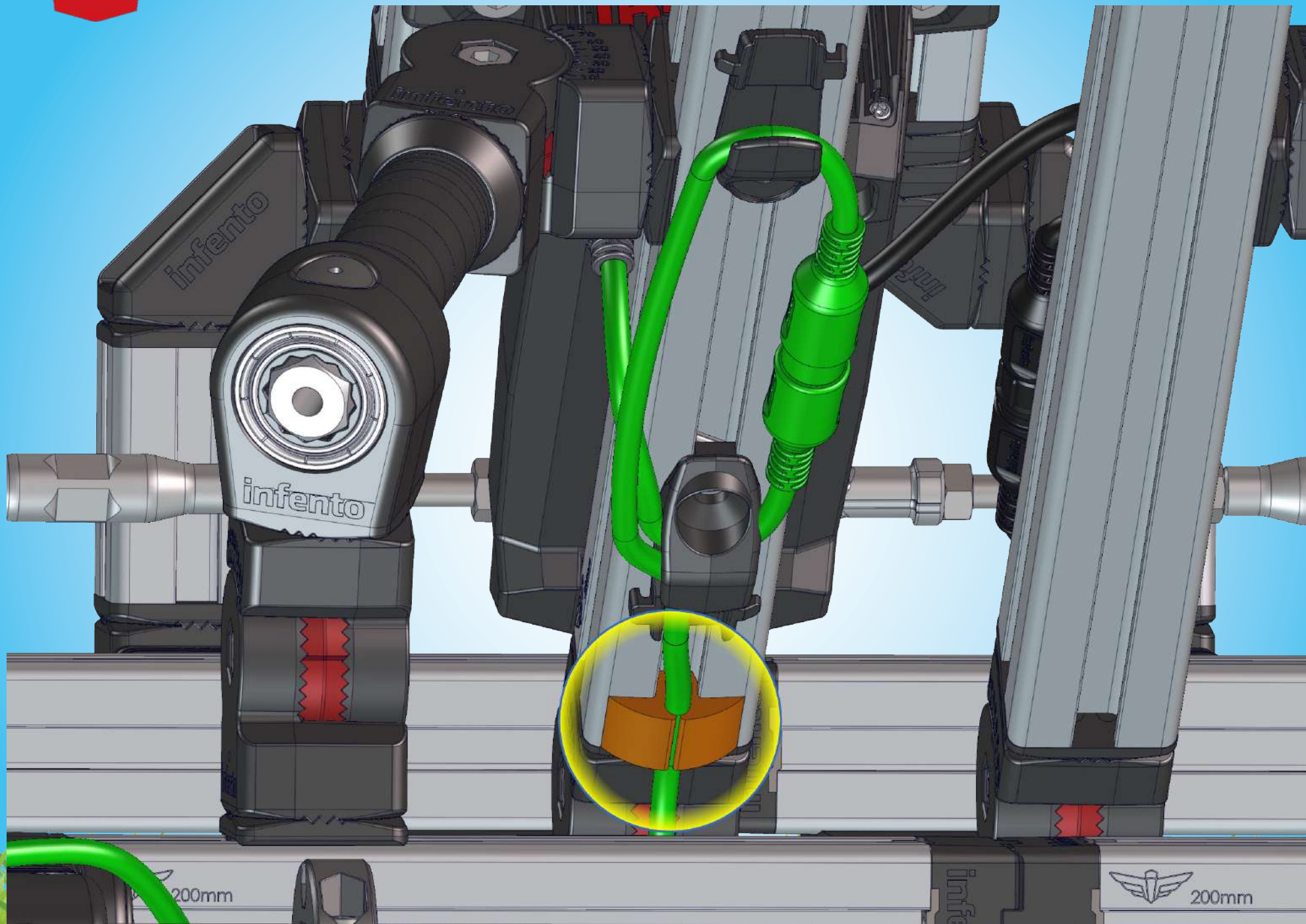

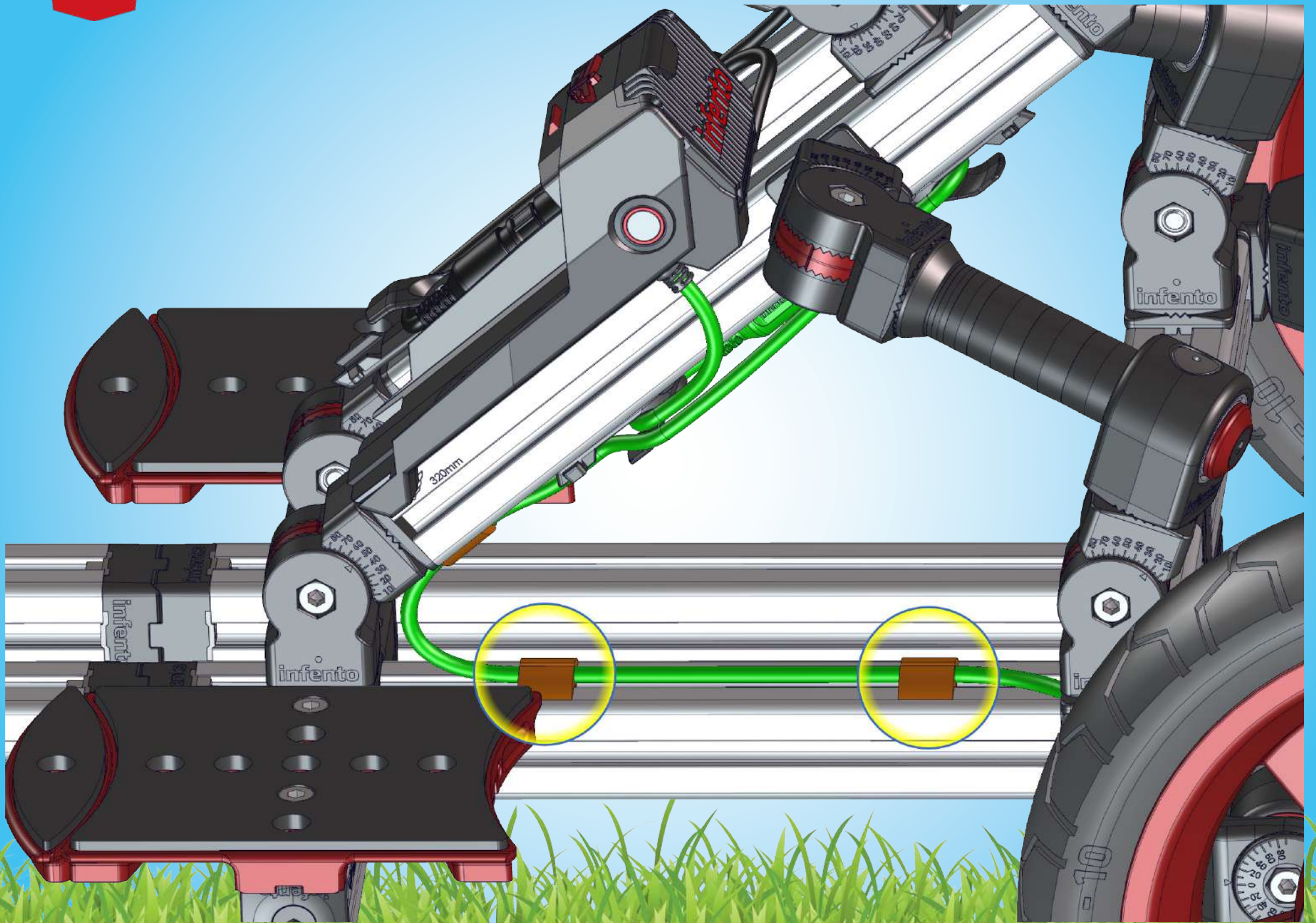

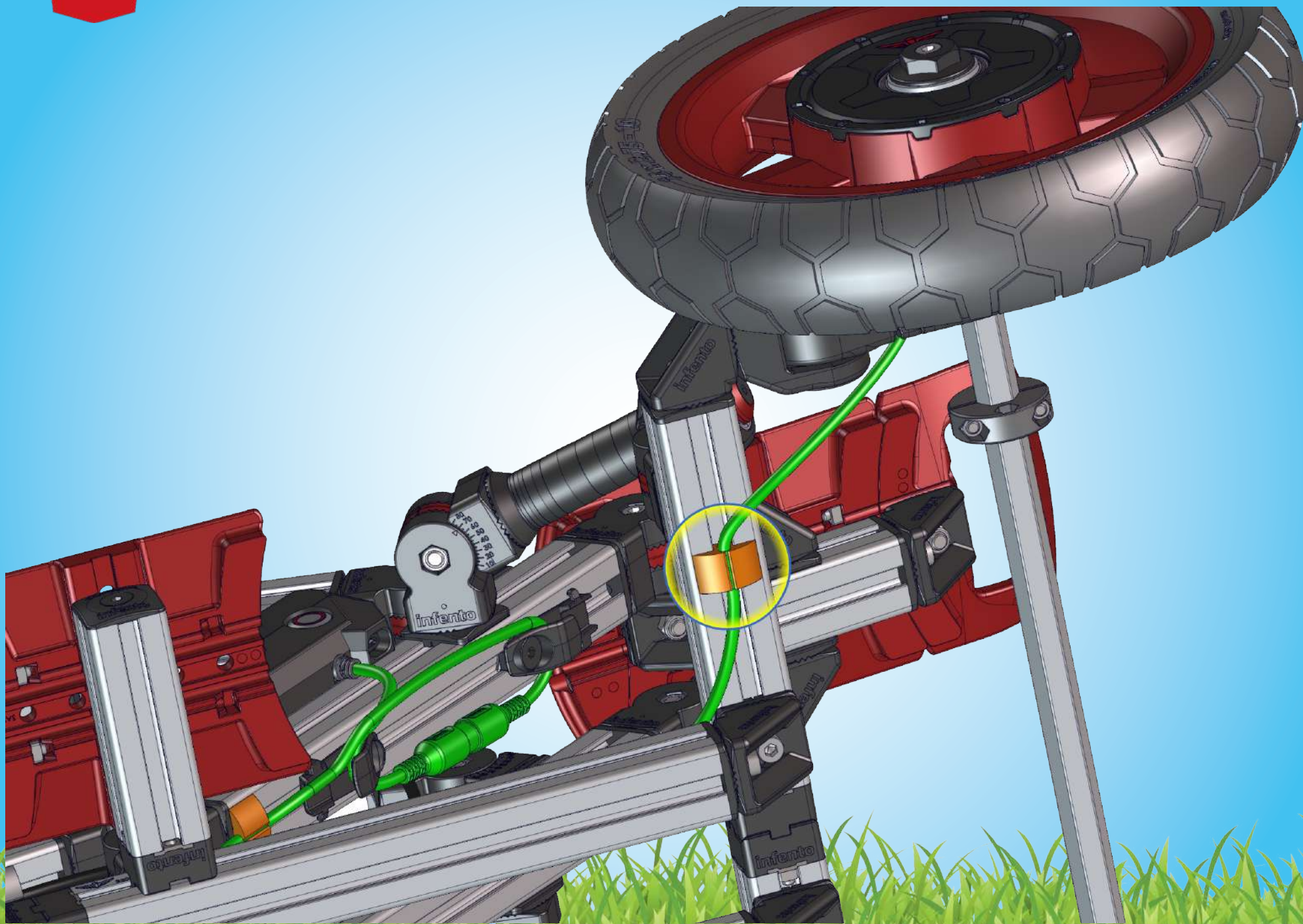

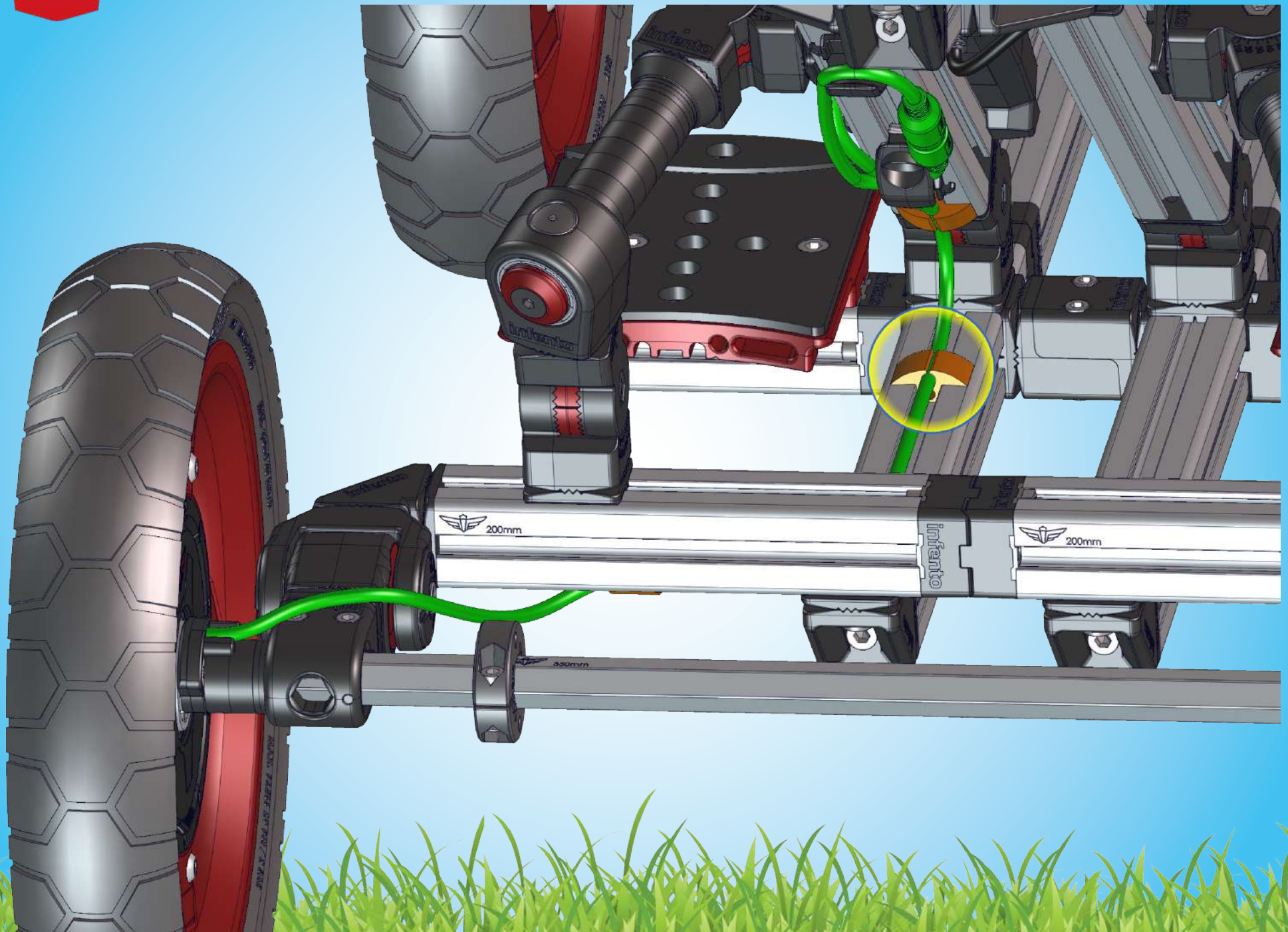



O-ring

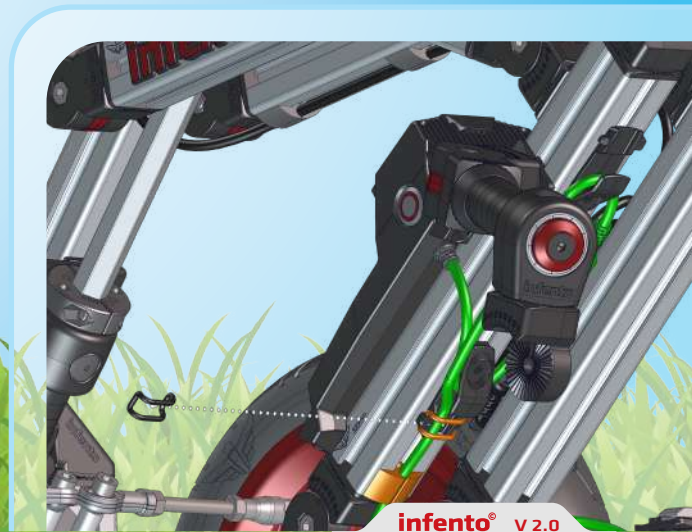



Brake cable 100 cm

1



2



3



4



5



6





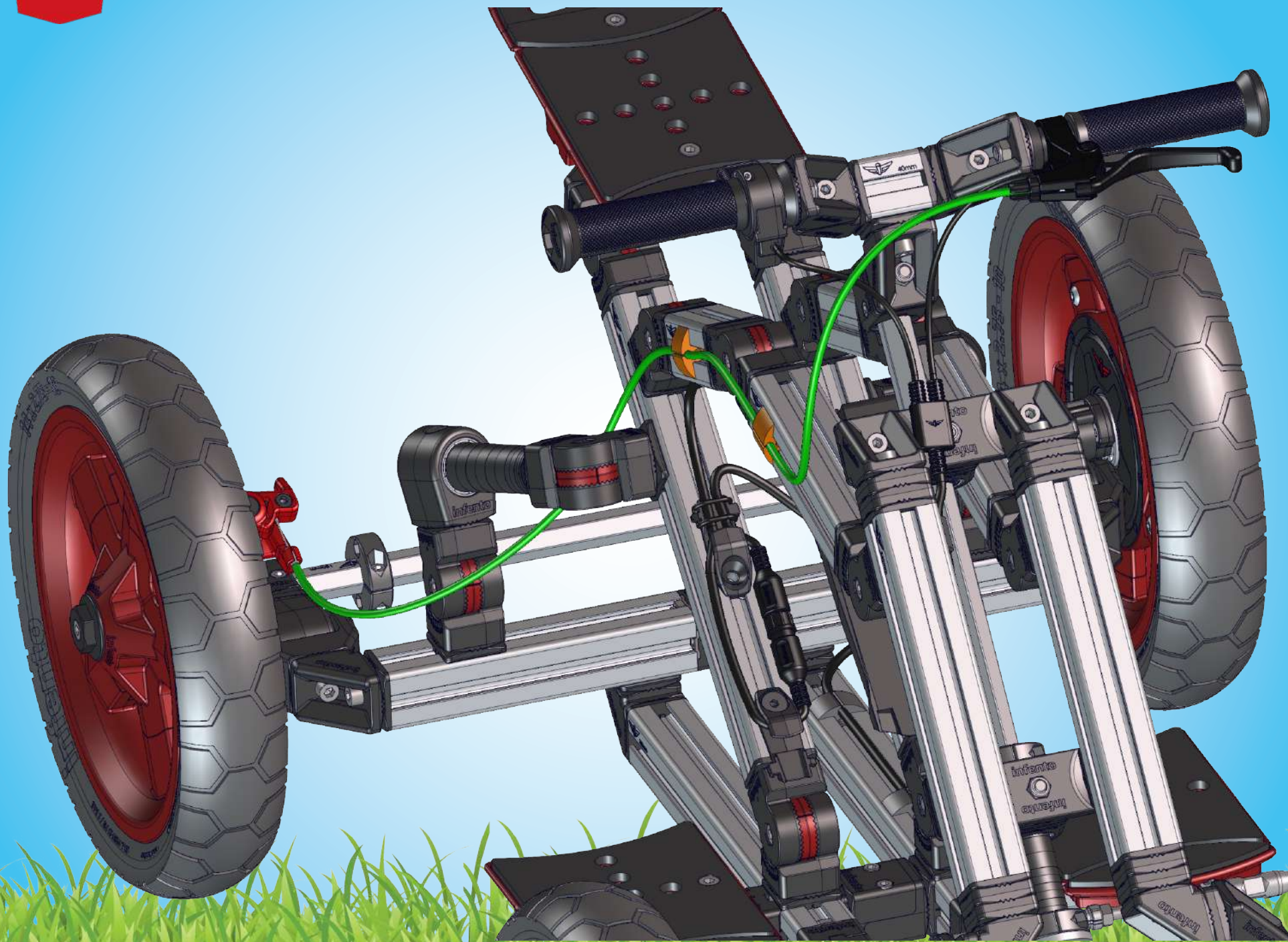

1

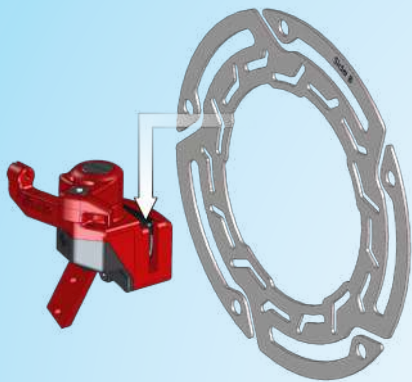

2

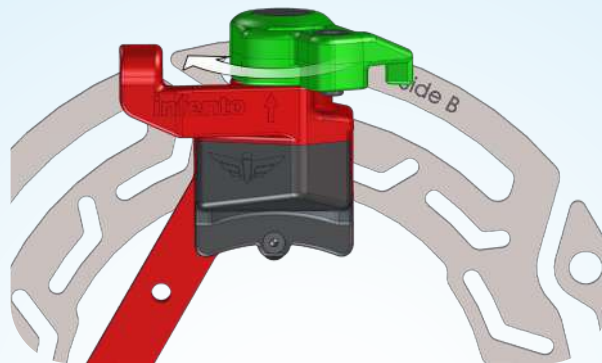

3

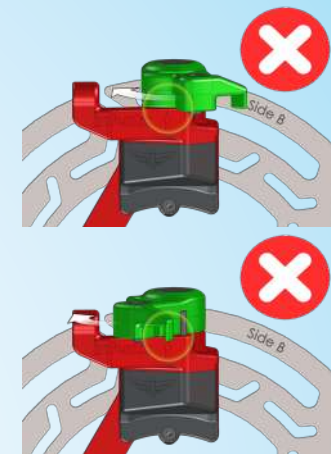

4

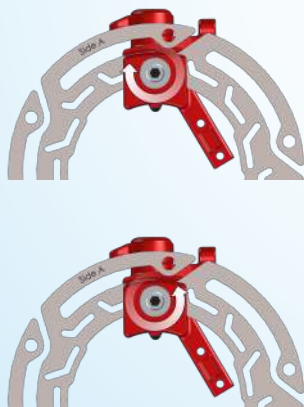

5

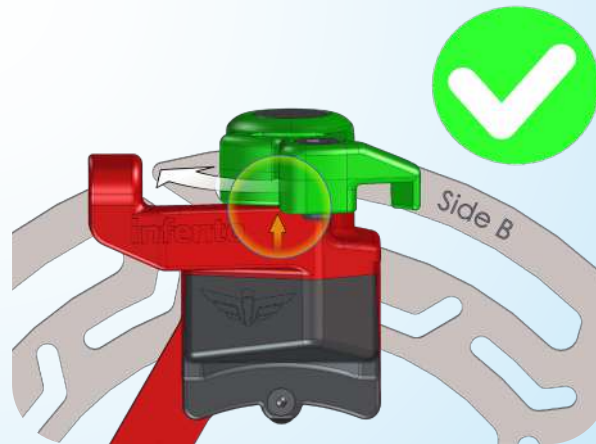

1

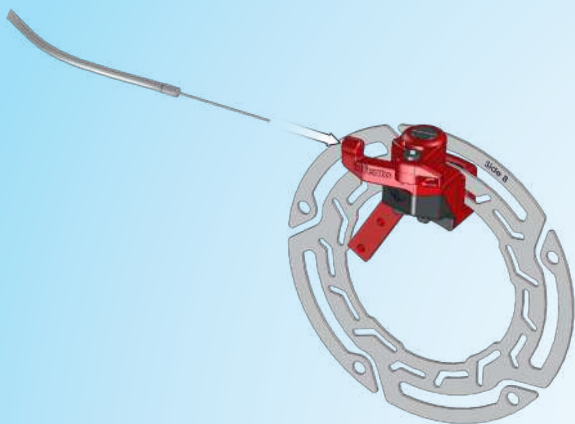

2

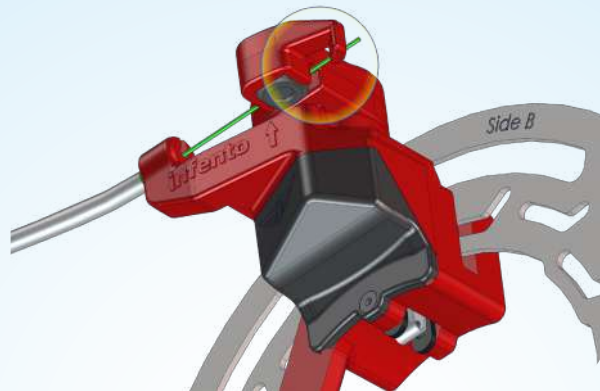

3

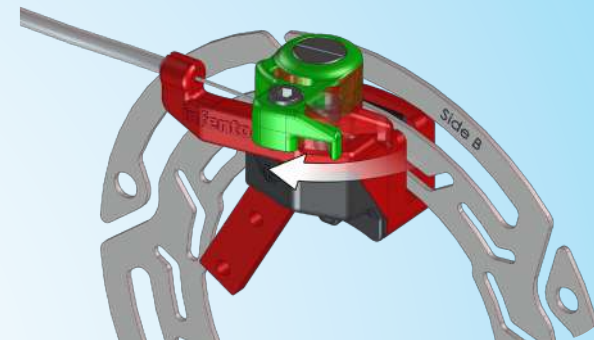

4

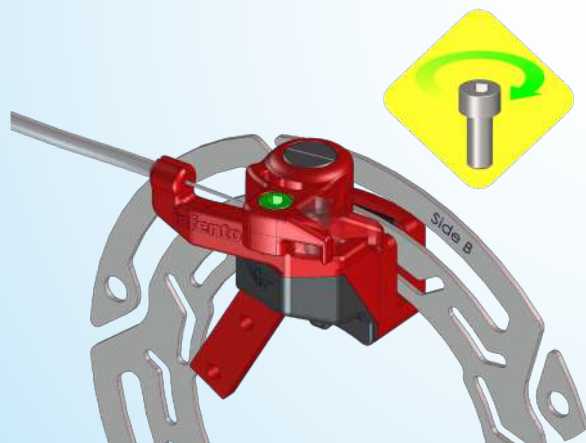

5

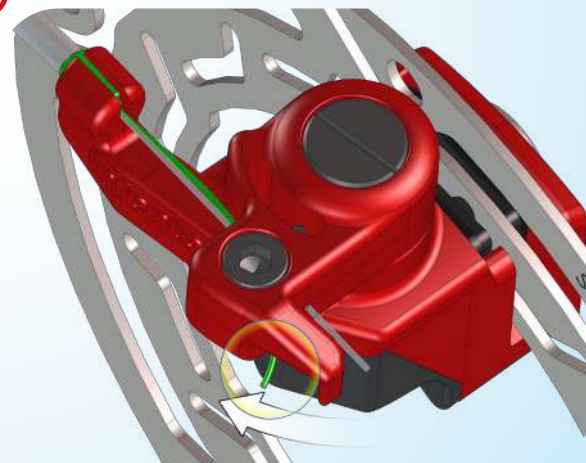



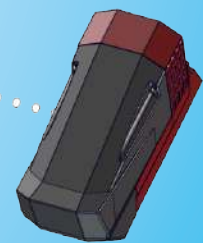
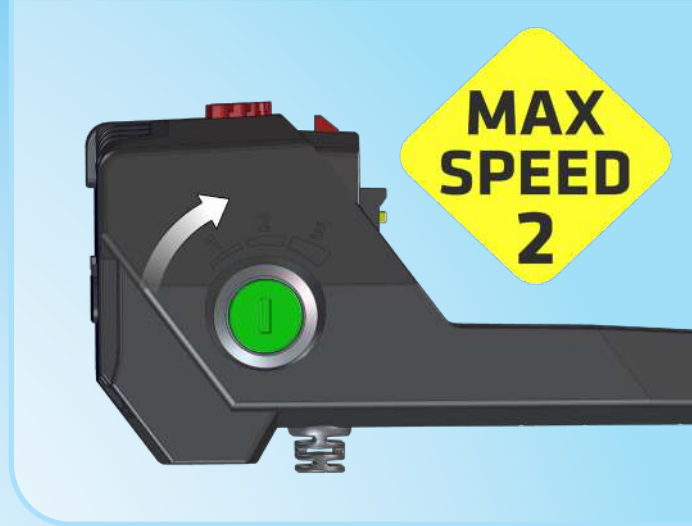

**Safety  
Check**

