



Age 4 - 14



50 kg | 110 lbs



97 cm - 166 cm
38 inch - 66 inch



LEVEL



2.5 h



FLOWMOTION^{G1}

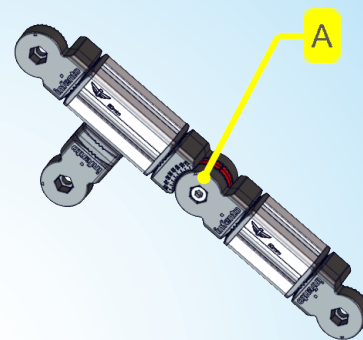
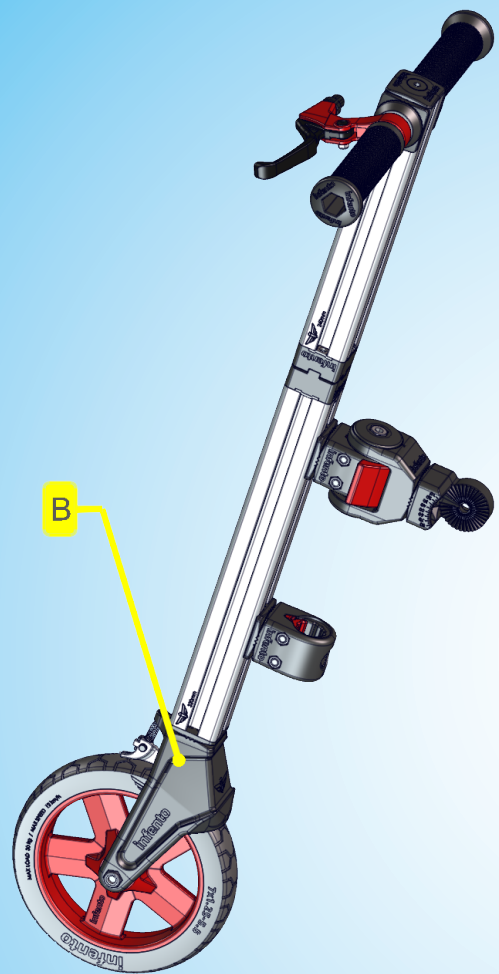

A.1







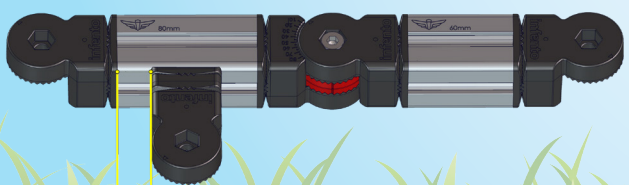
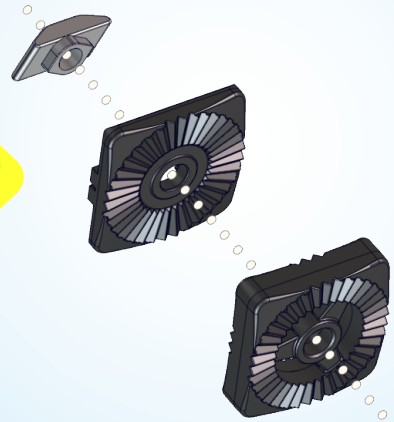
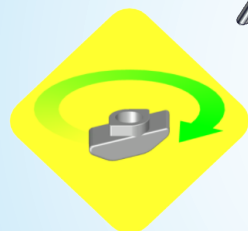
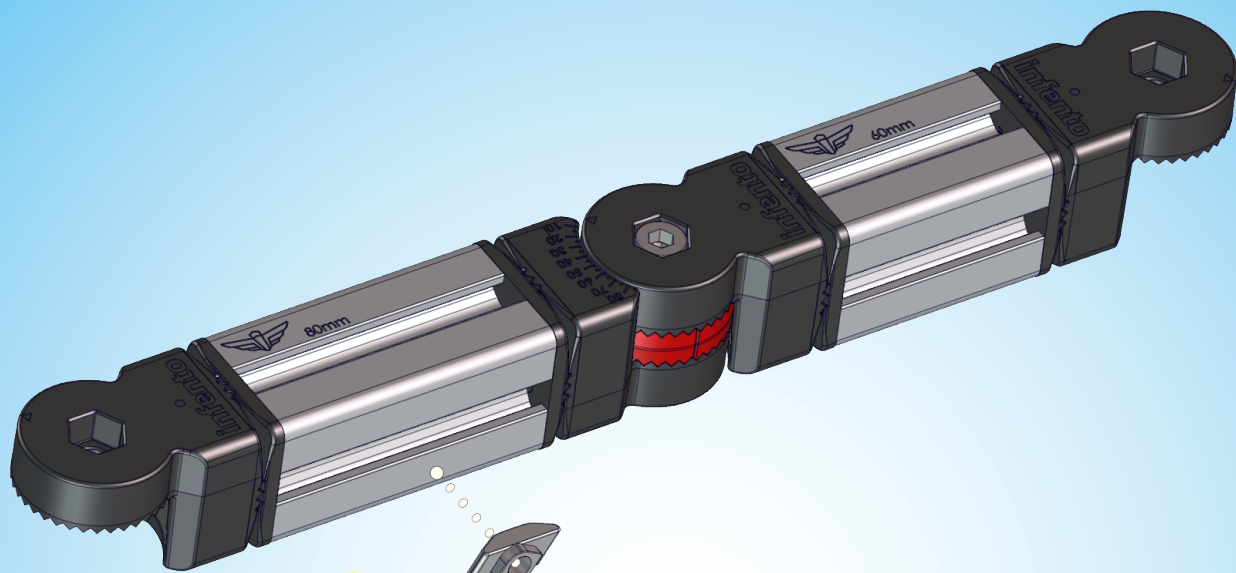

19 mm

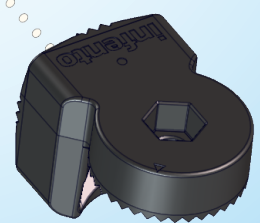

Bolt_M8x30



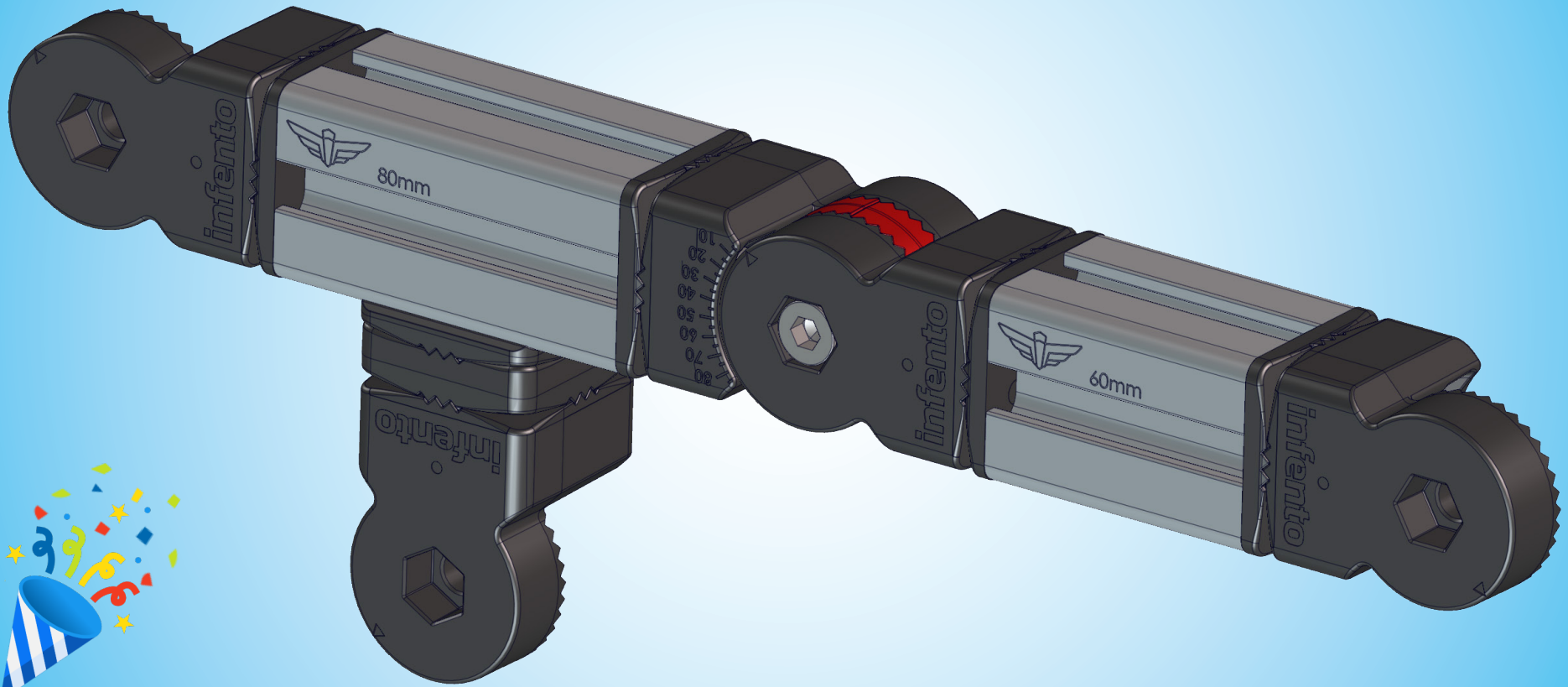

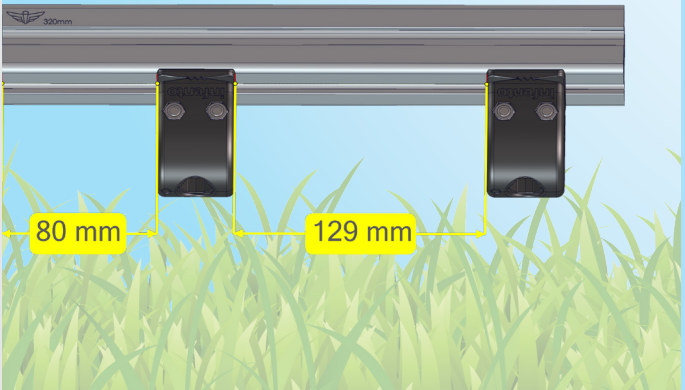

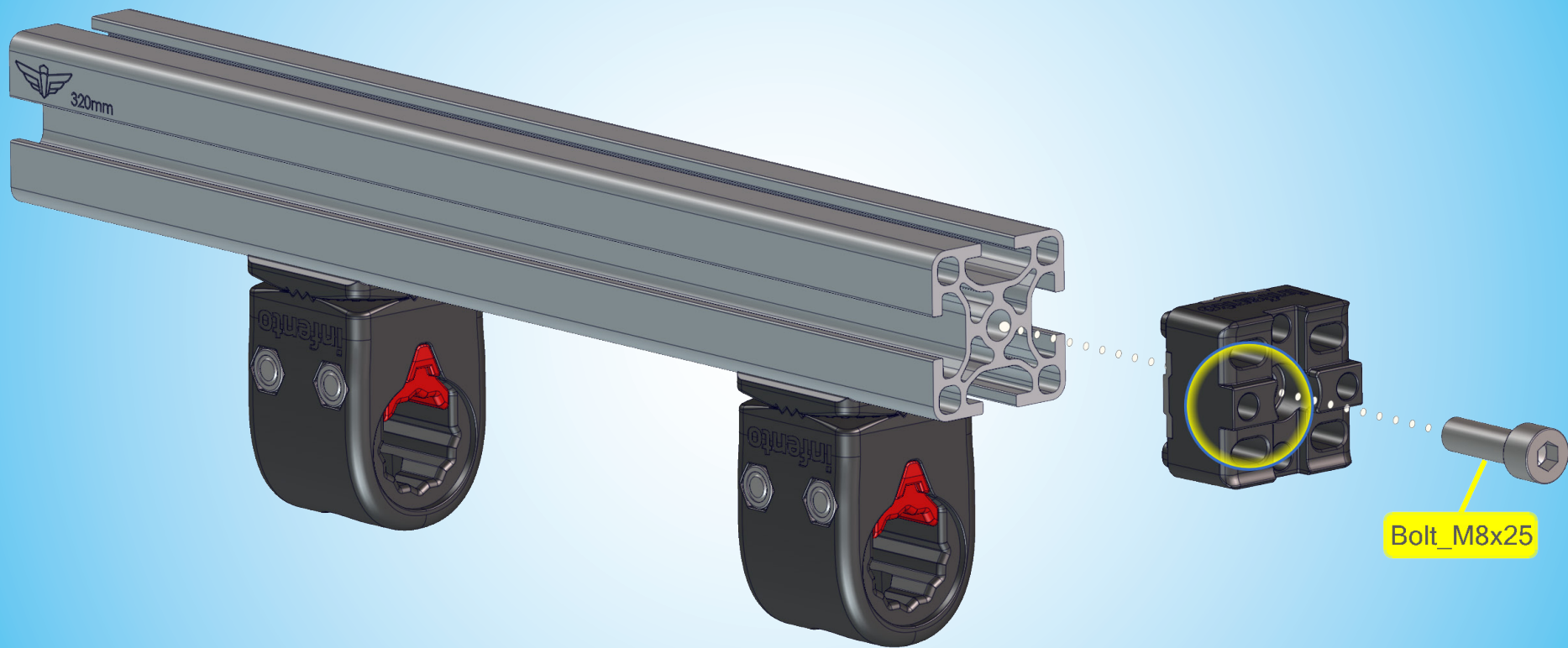

Bolt_M8x25

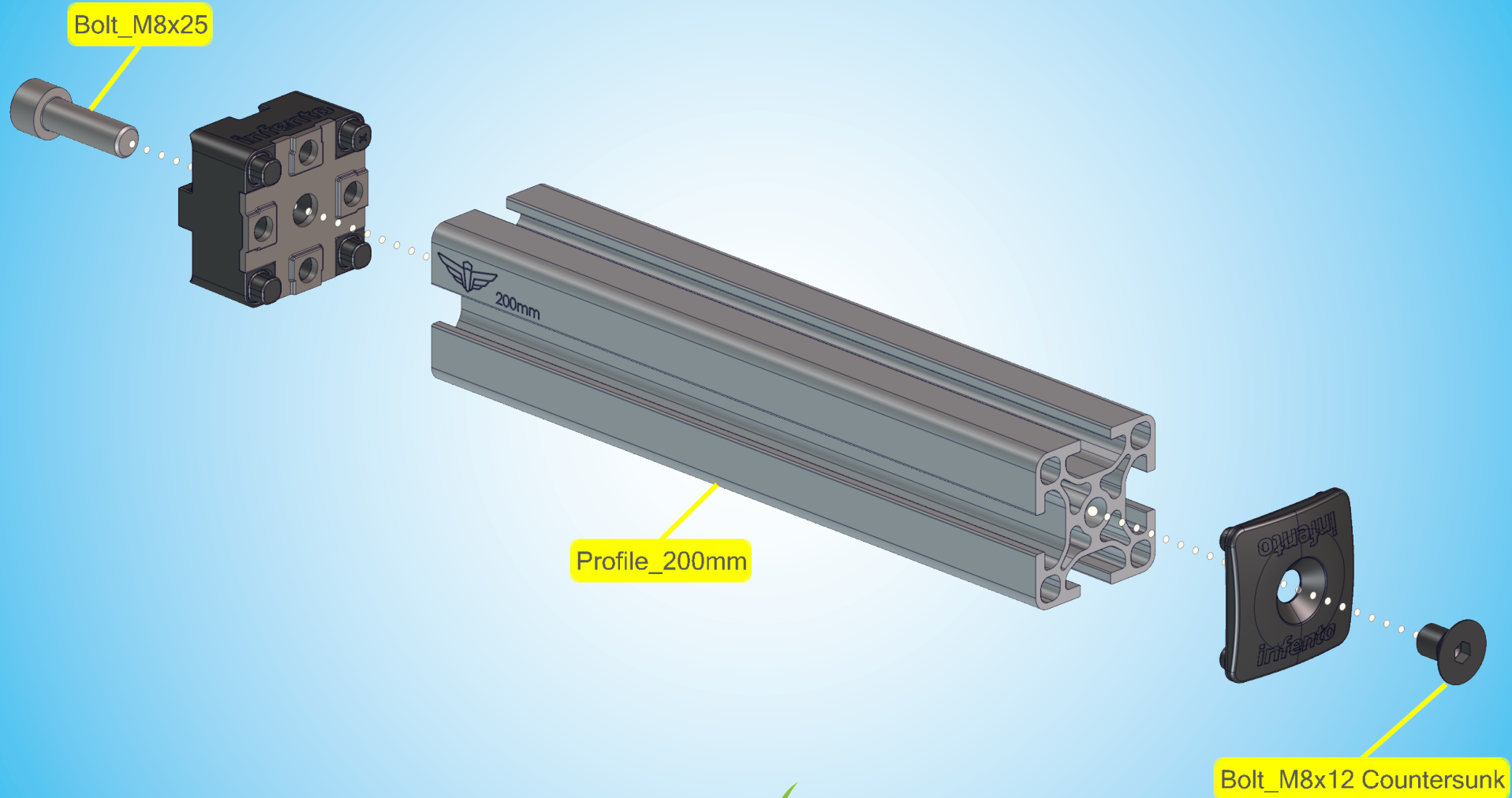

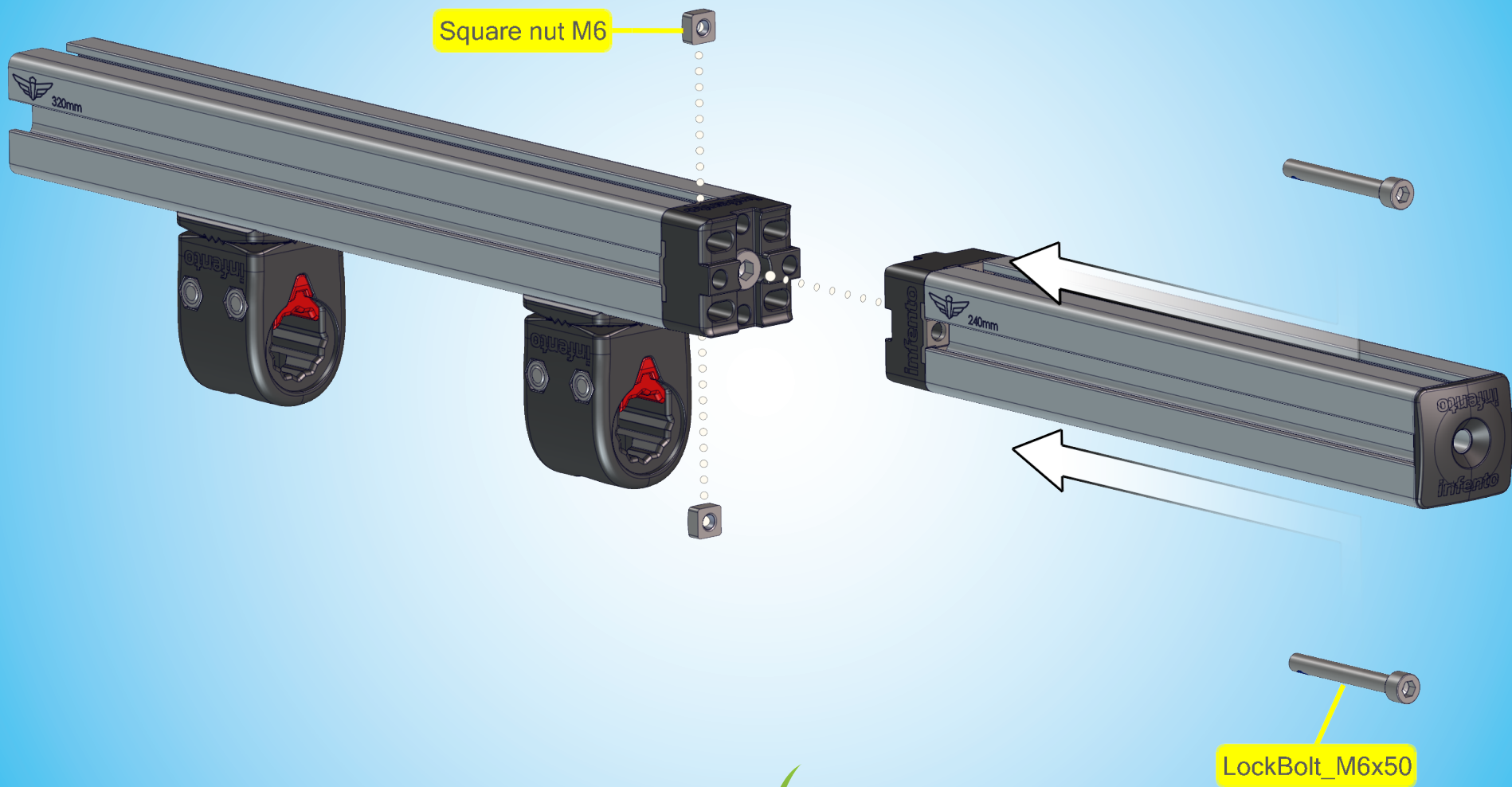



Locknut M8

Bolt_M8x25

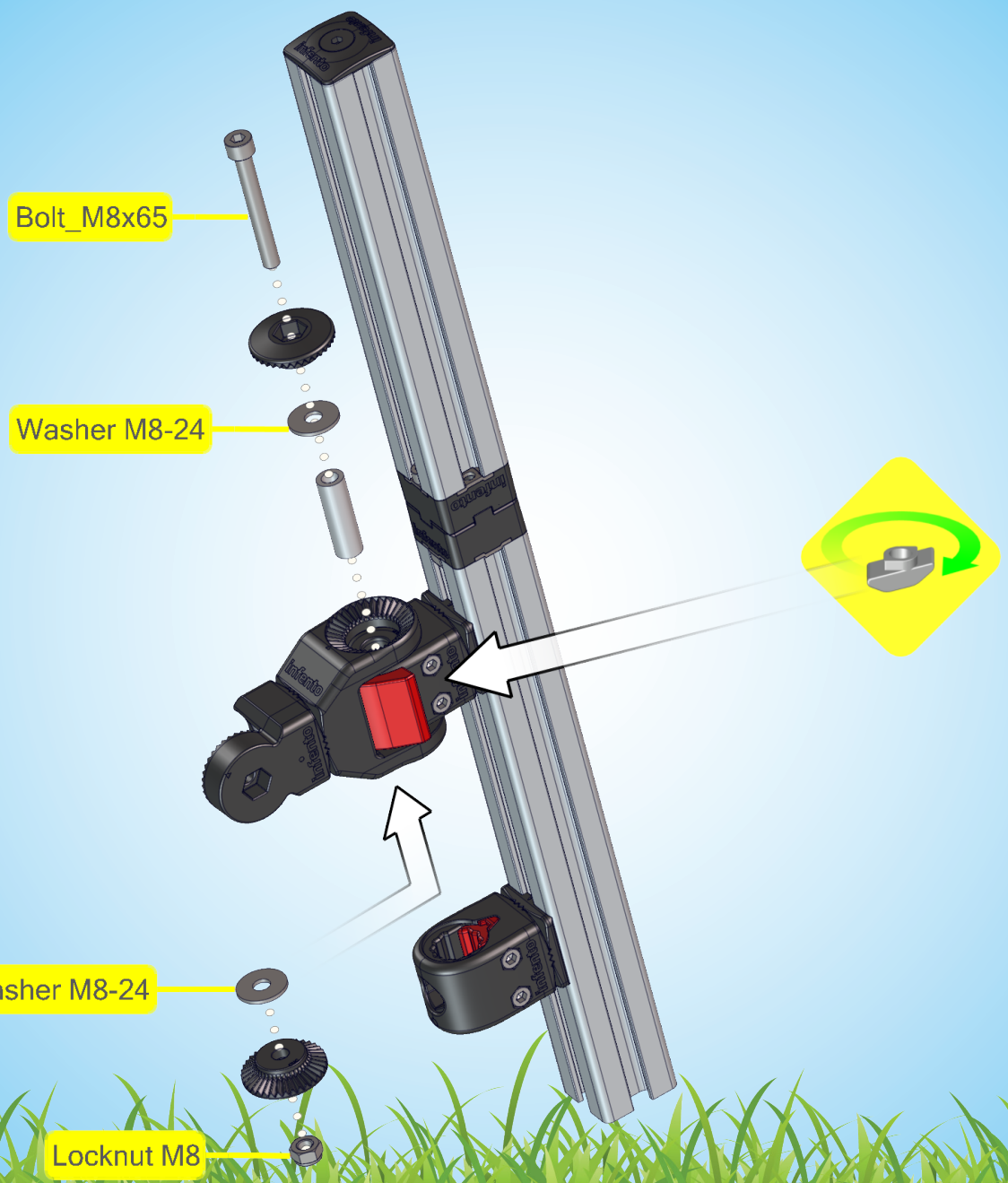

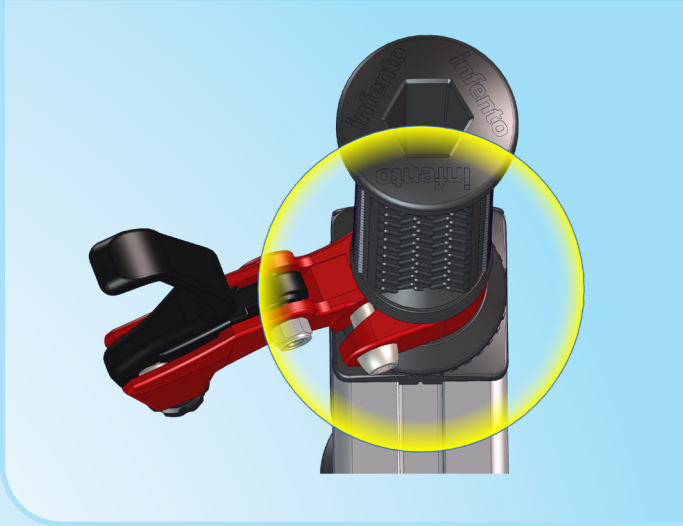



Bolt_M8x35

Washer M8-24







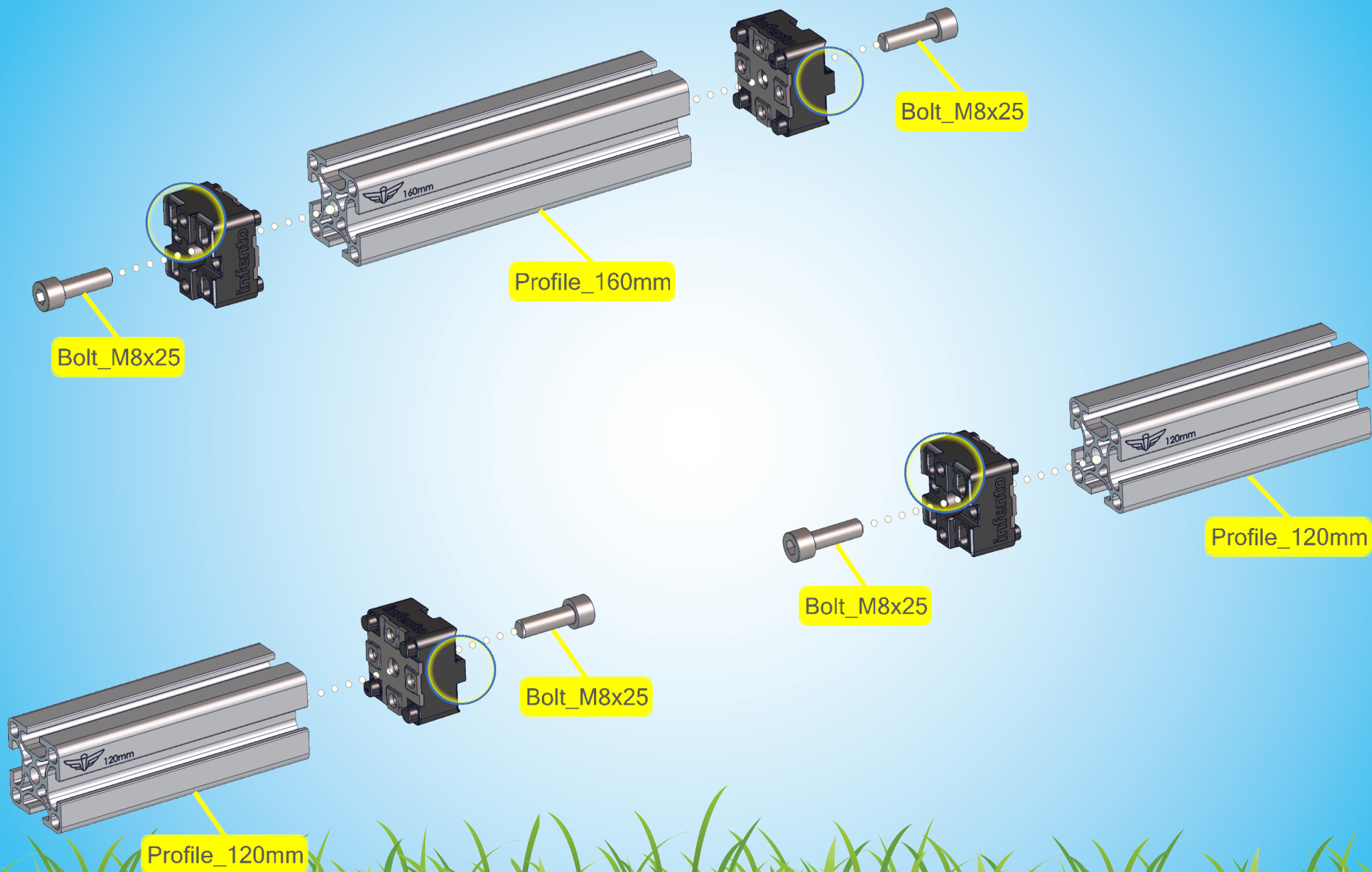

LockBolt_M6x50

Square nut M6

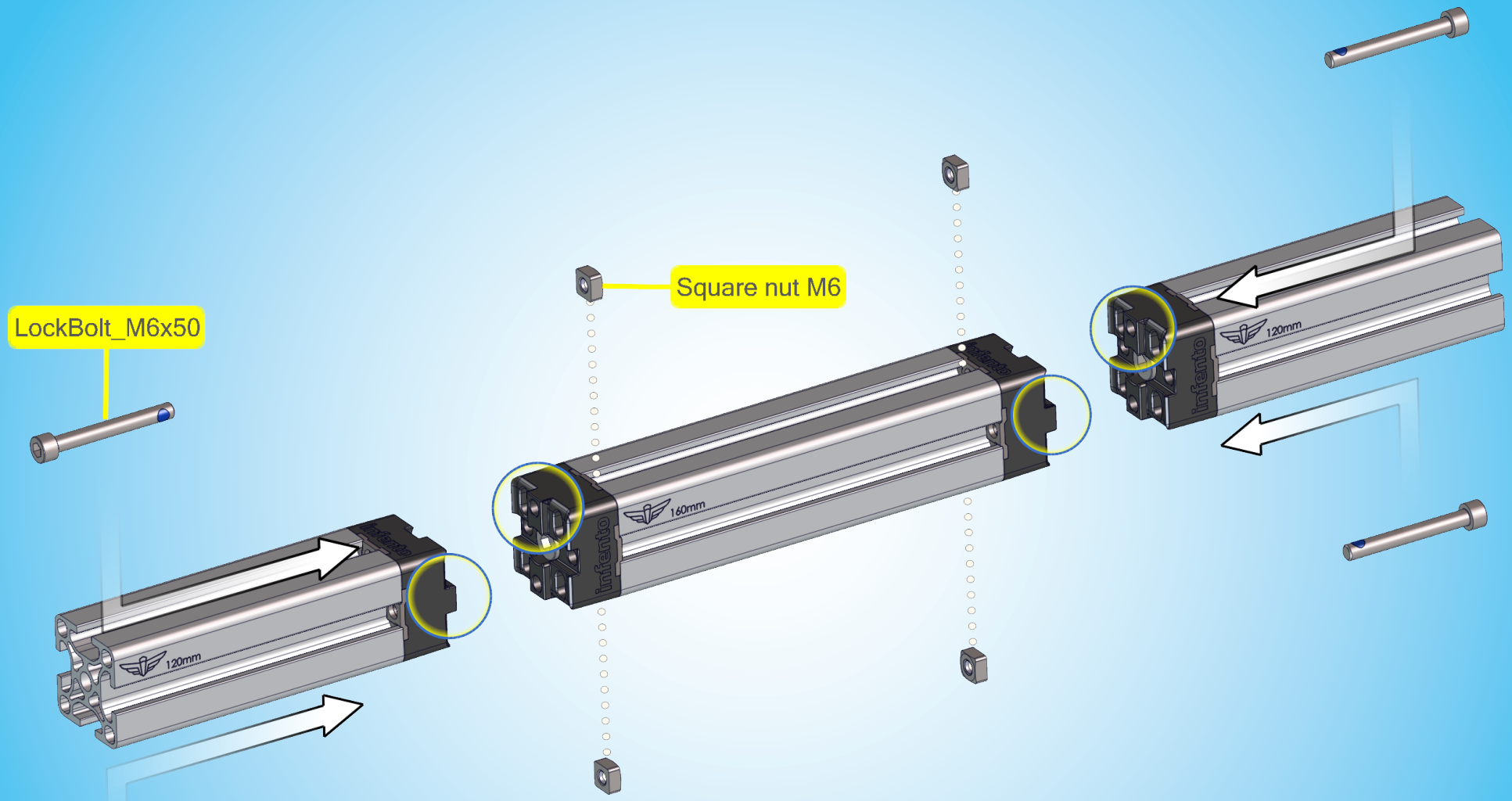

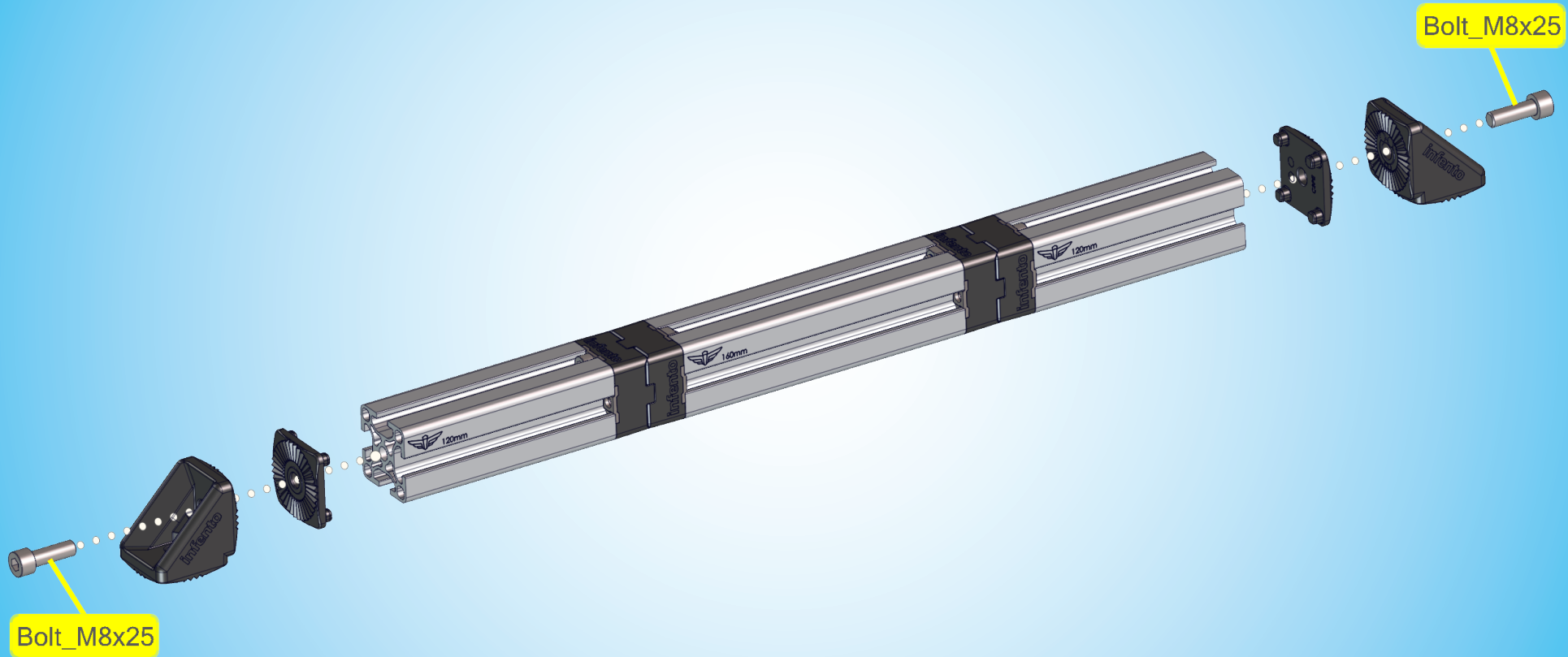

Bolt_M8x25

Bolt_M8x25

infento

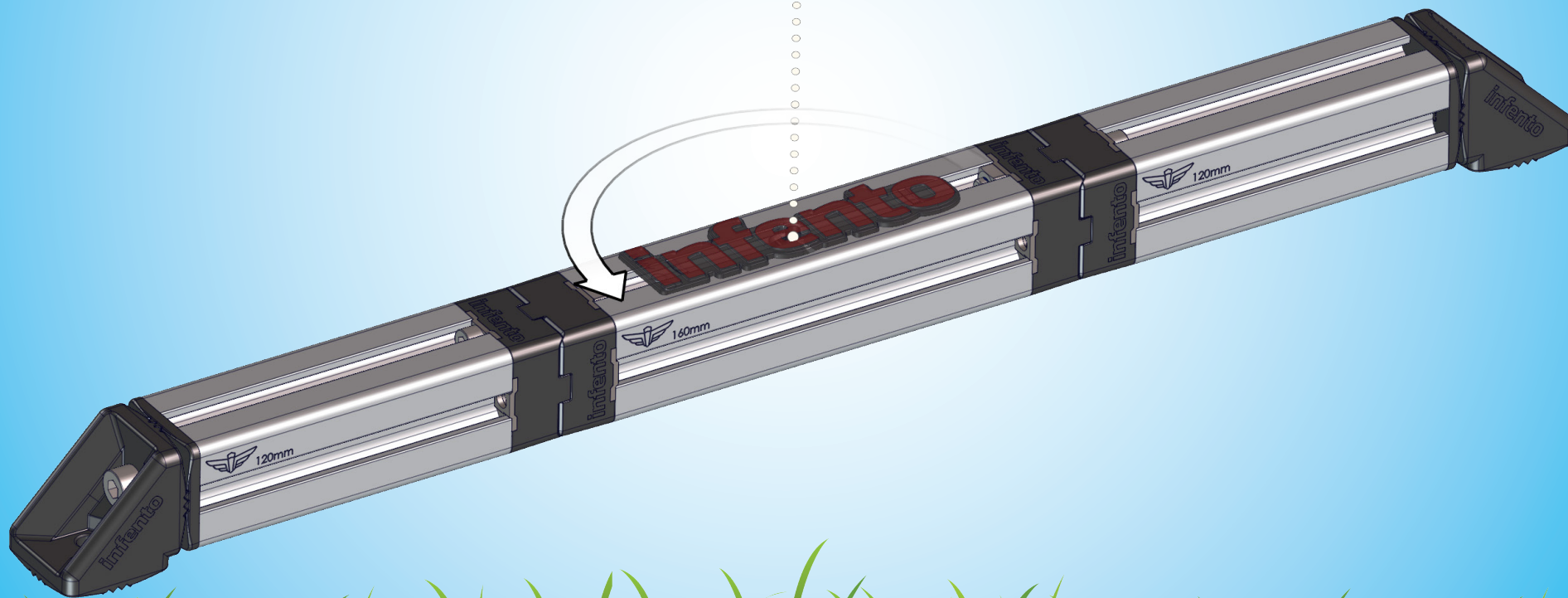

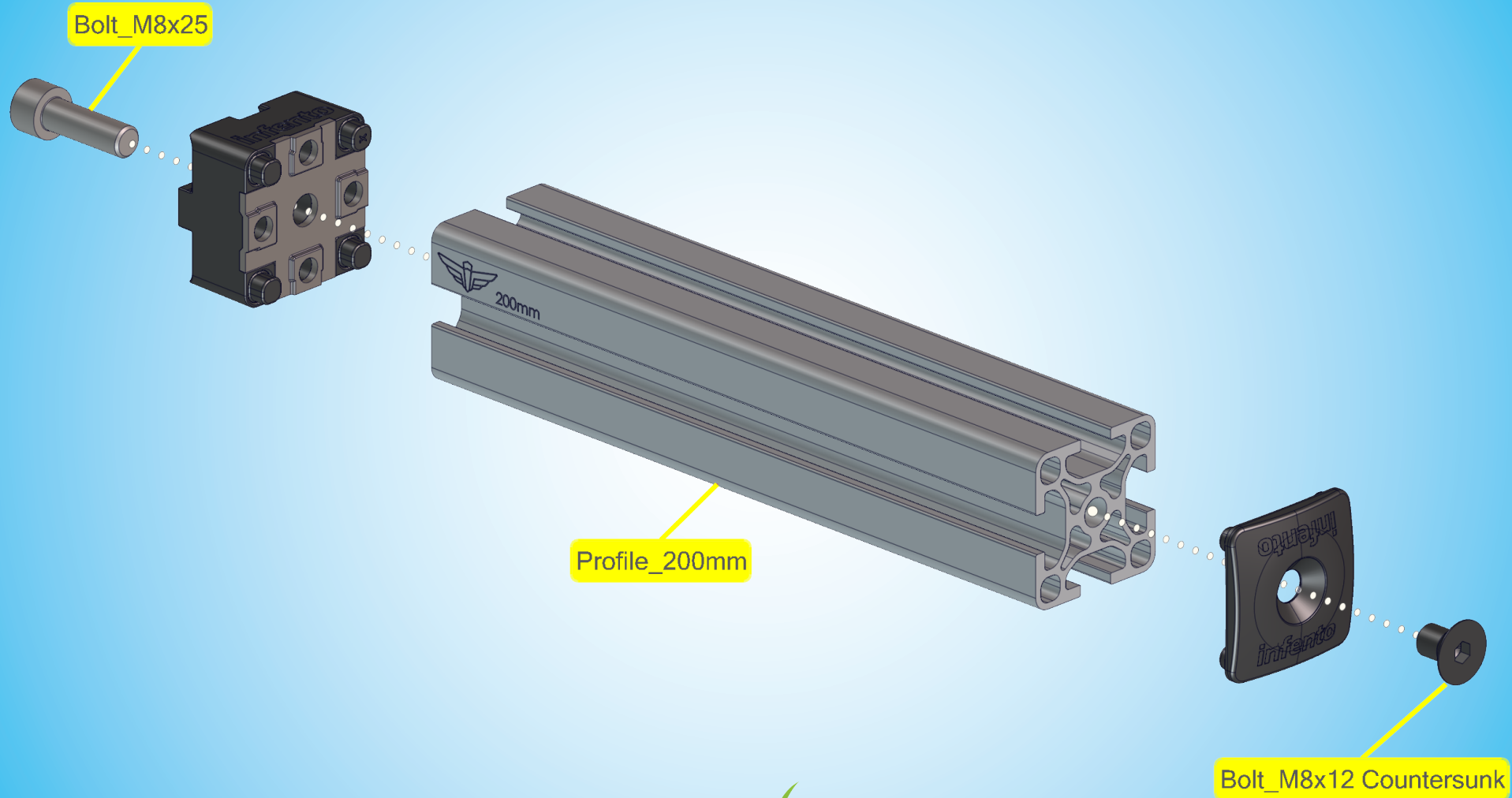

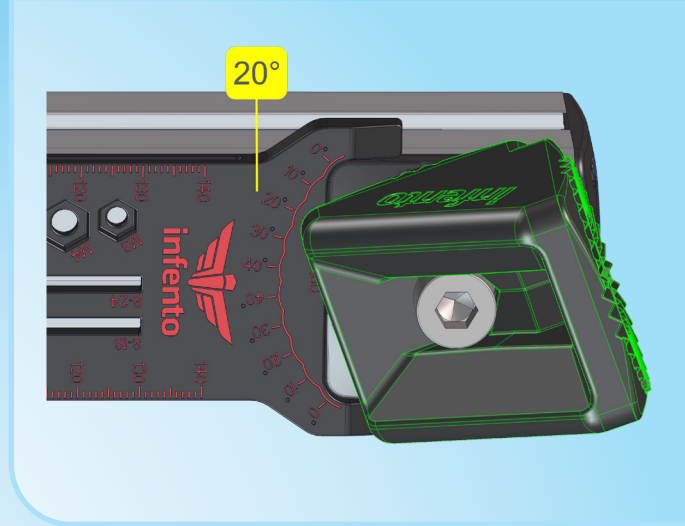

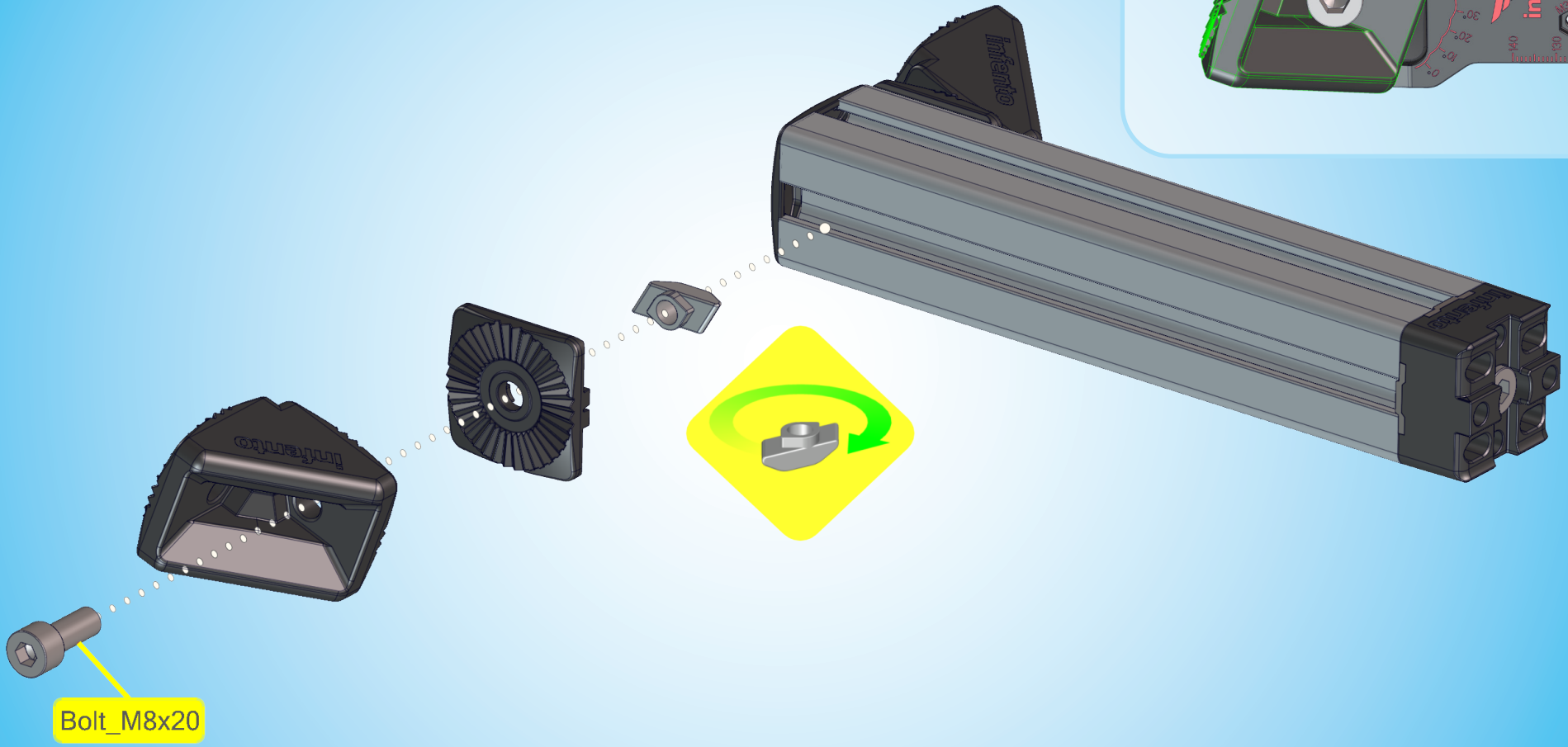
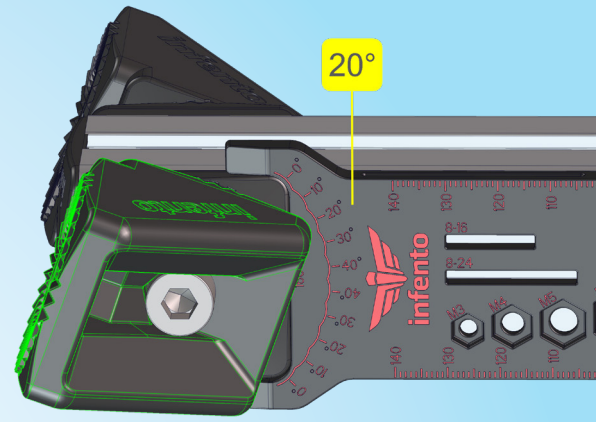



Bolt_M8x35

10 mm

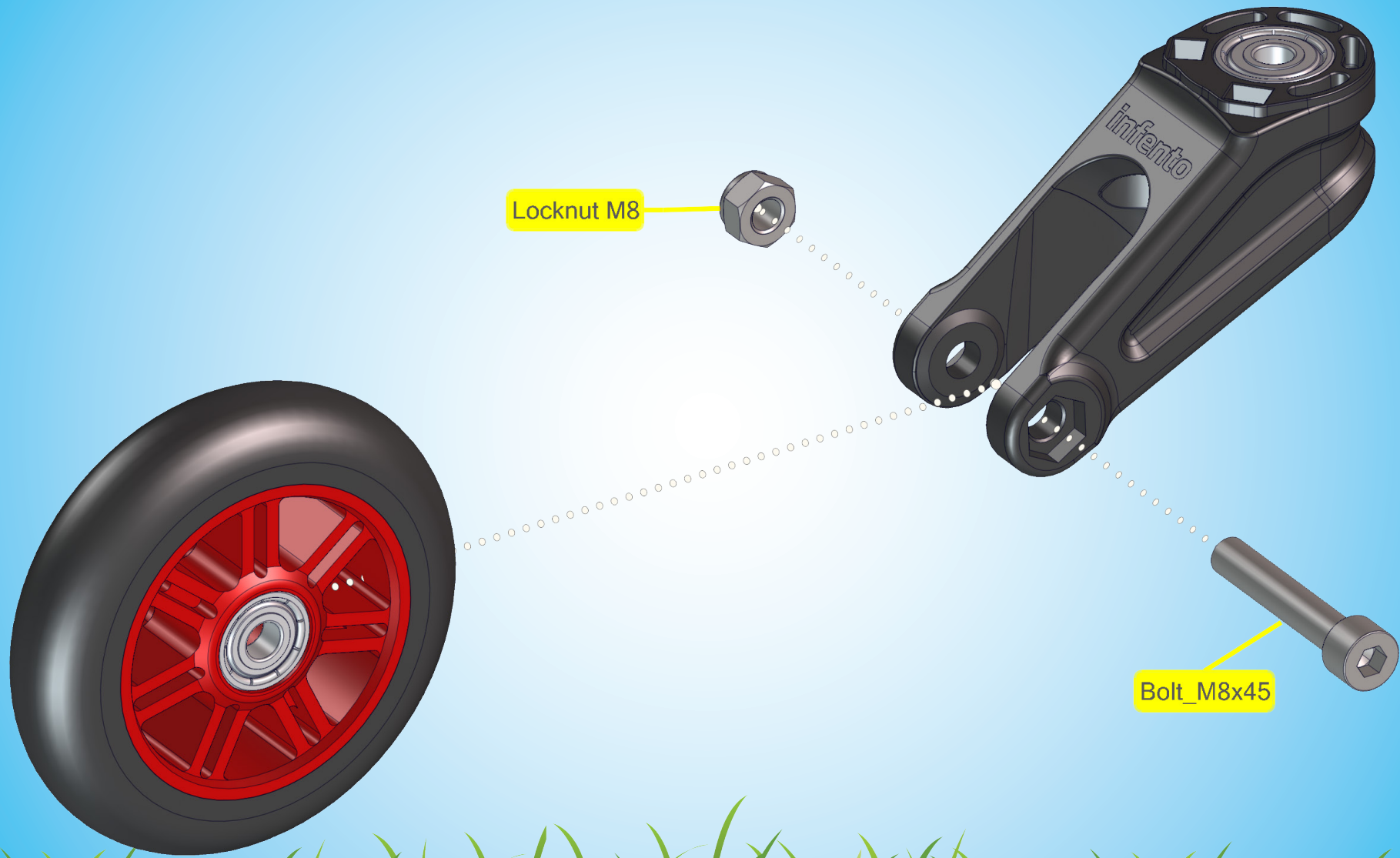

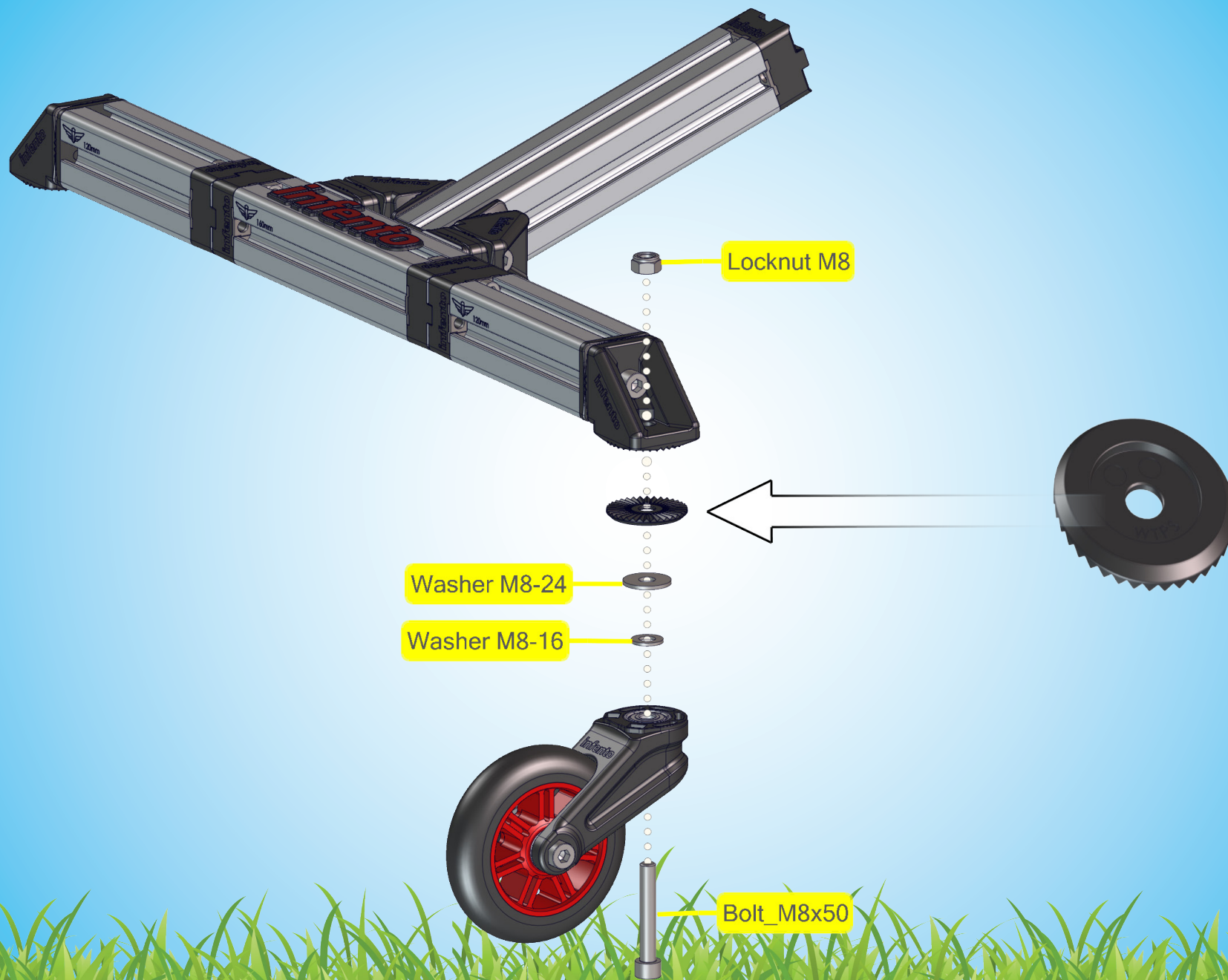



Bolt_M8x45

Locknut M8



Locknut M8

Washer M8-24

Washer M8-16

Bolt_M8x50

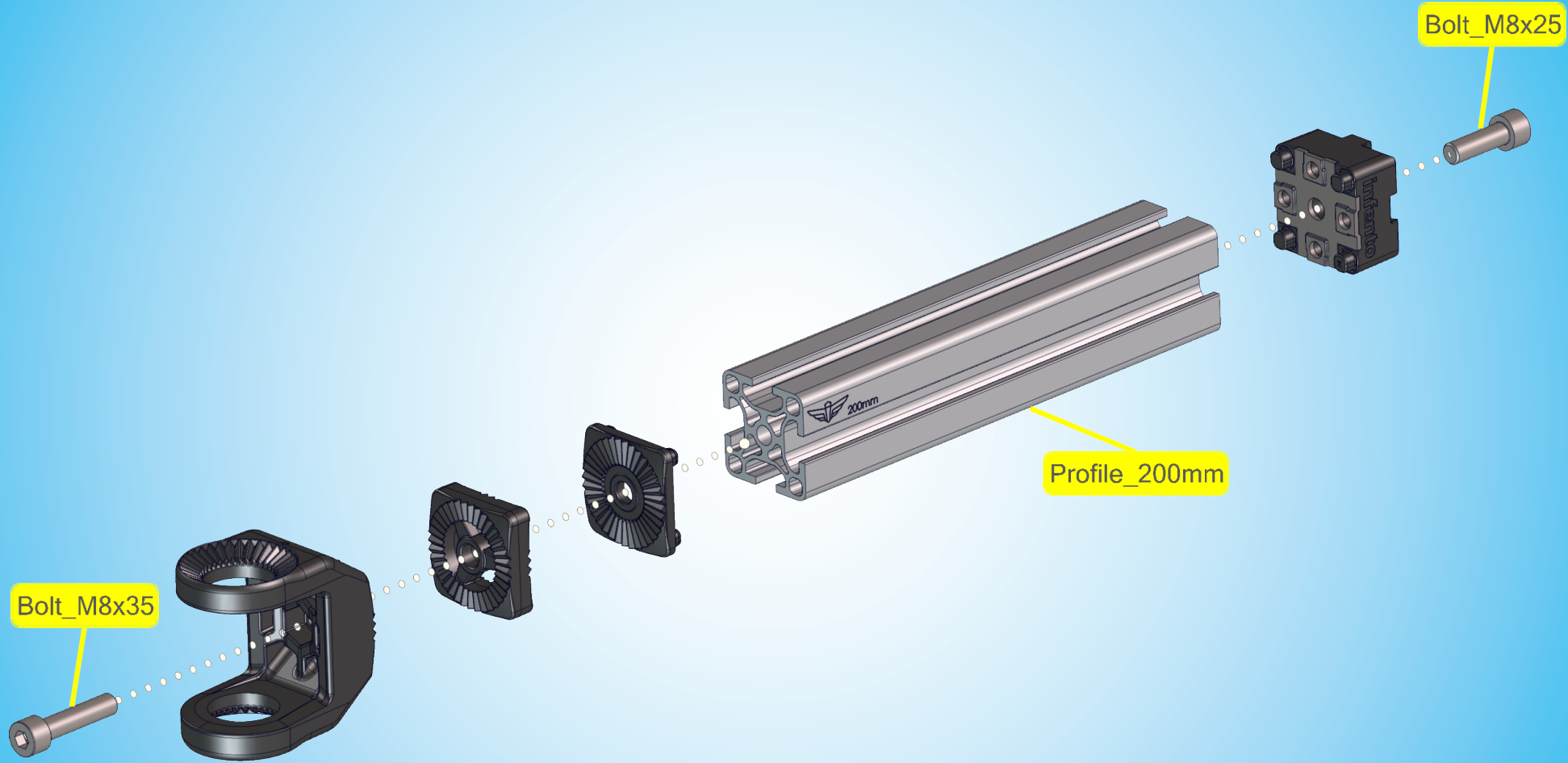





Bolt_M8x20

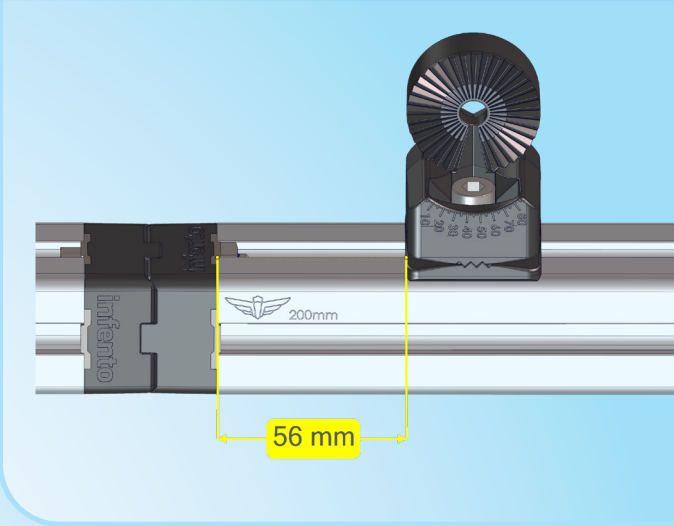

56 mm

200mm

Bolt_M8x35

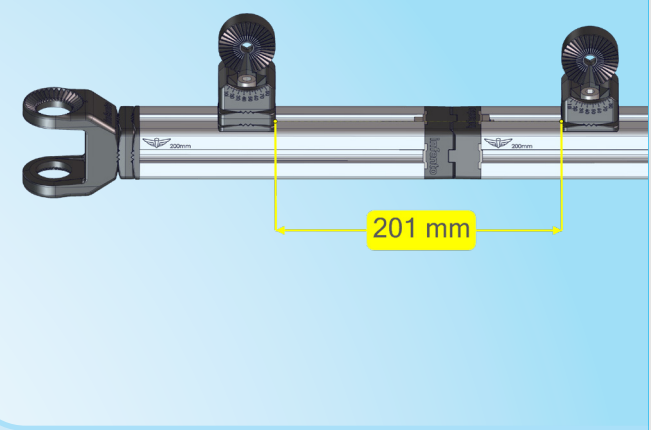

2x

LockBolt_M6x50

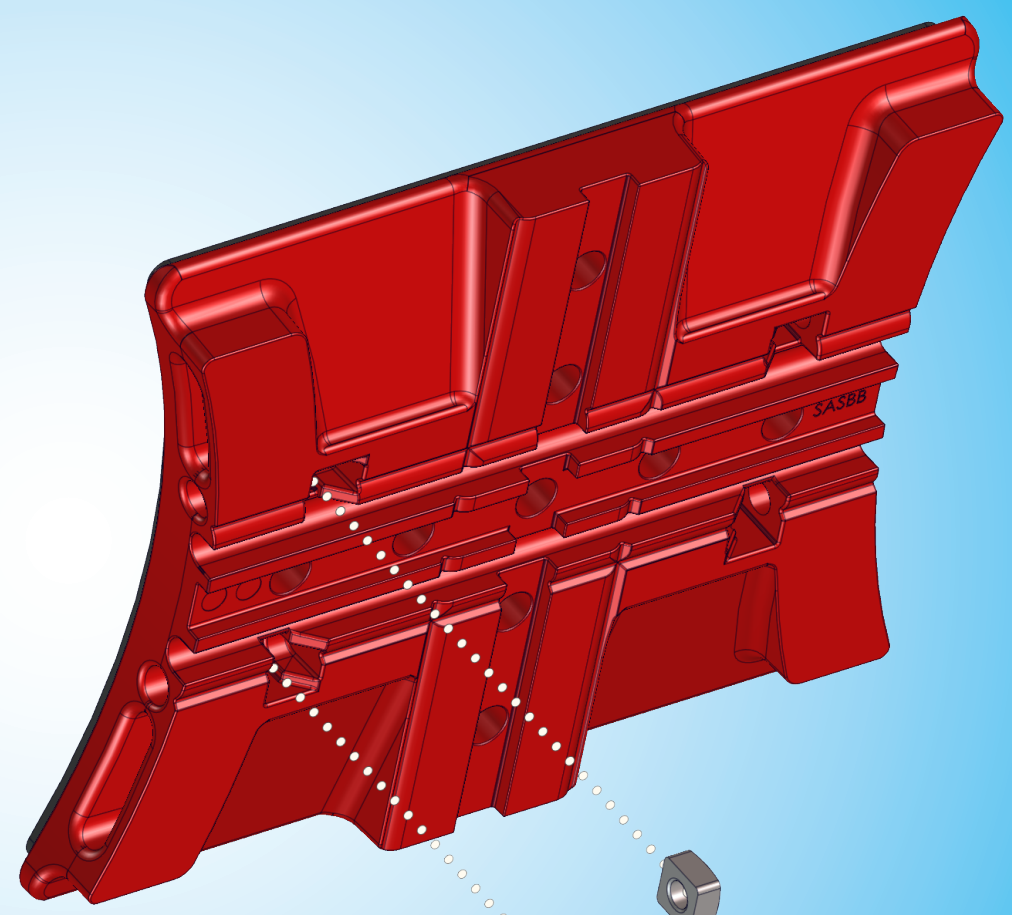
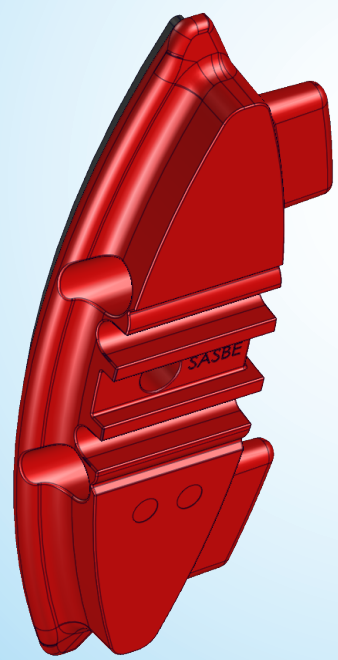
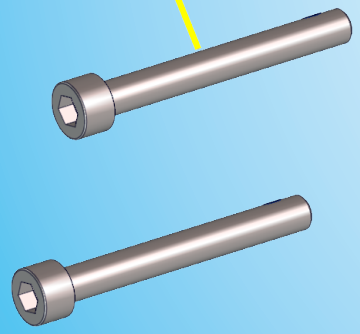

Square nut M6



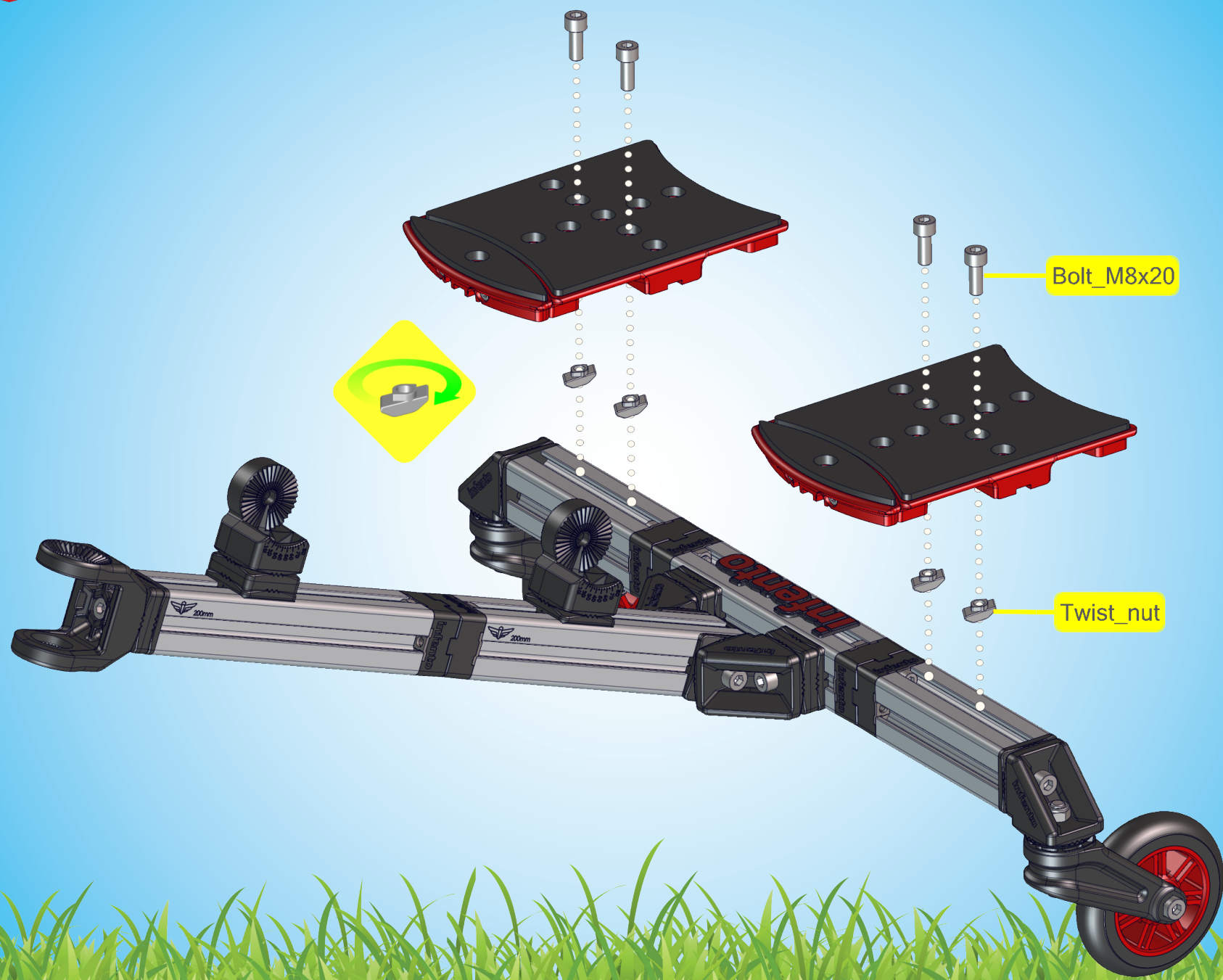

Bolt_M8x20

Twist_nut





Bolt_M8x65

Washer M8-24

Washer M8-24

Locknut M8

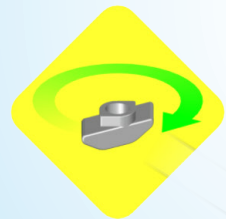

D.4



1

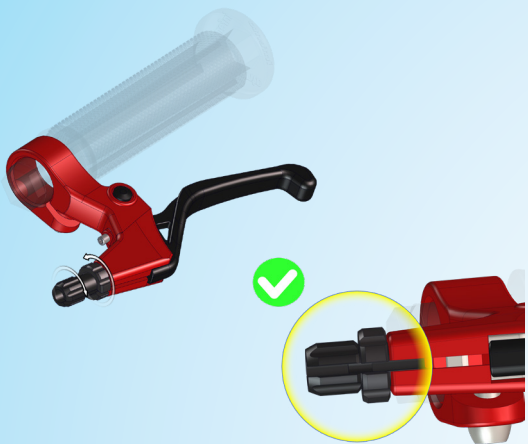

2

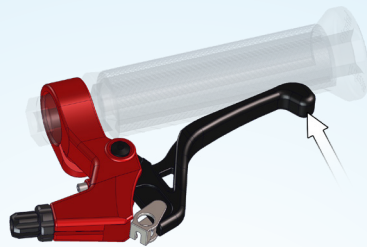

3



4



5



6

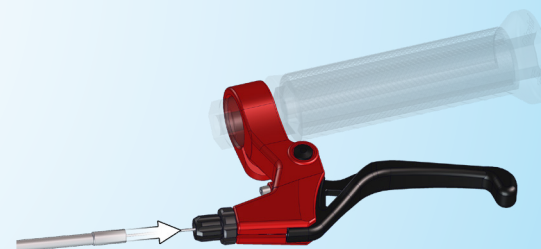

1

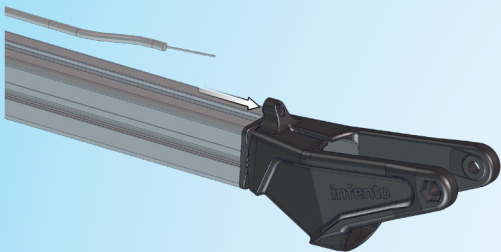

2

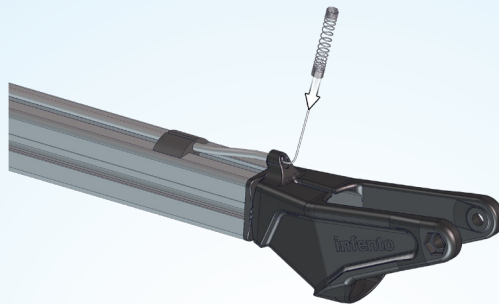

3

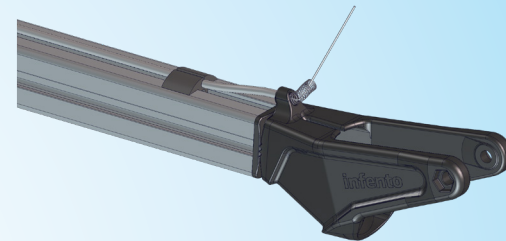

4

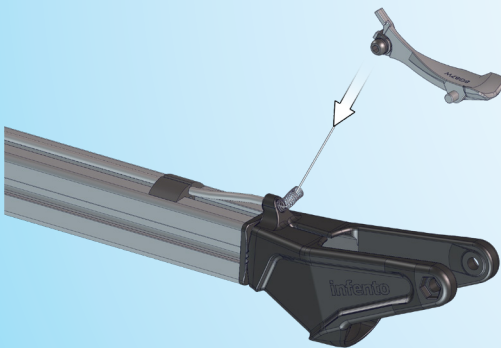

5

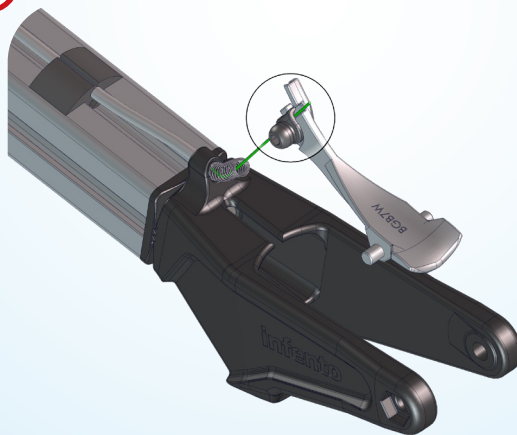

6

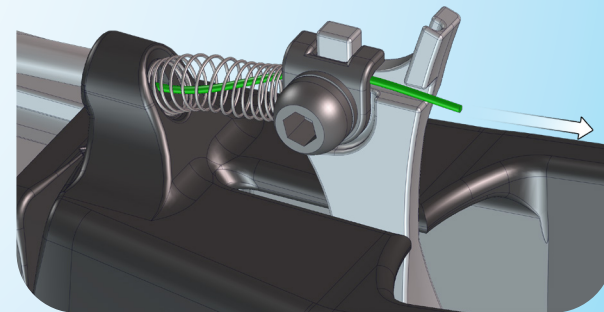

7

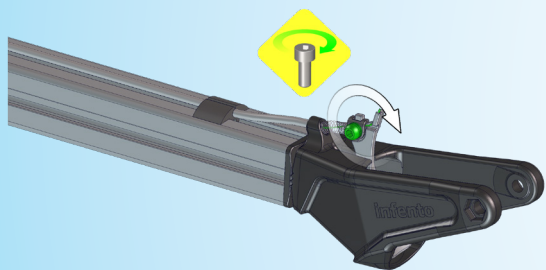

8

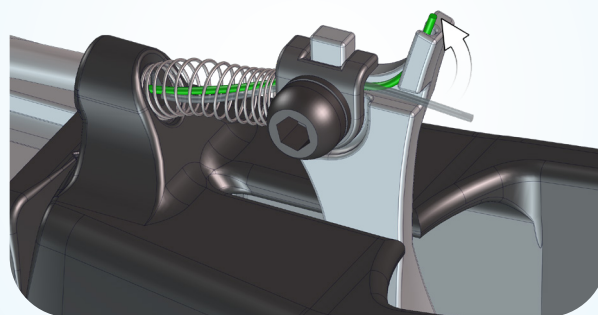

9

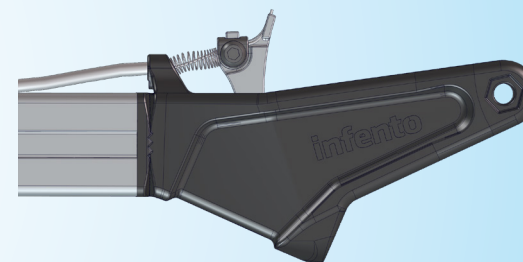



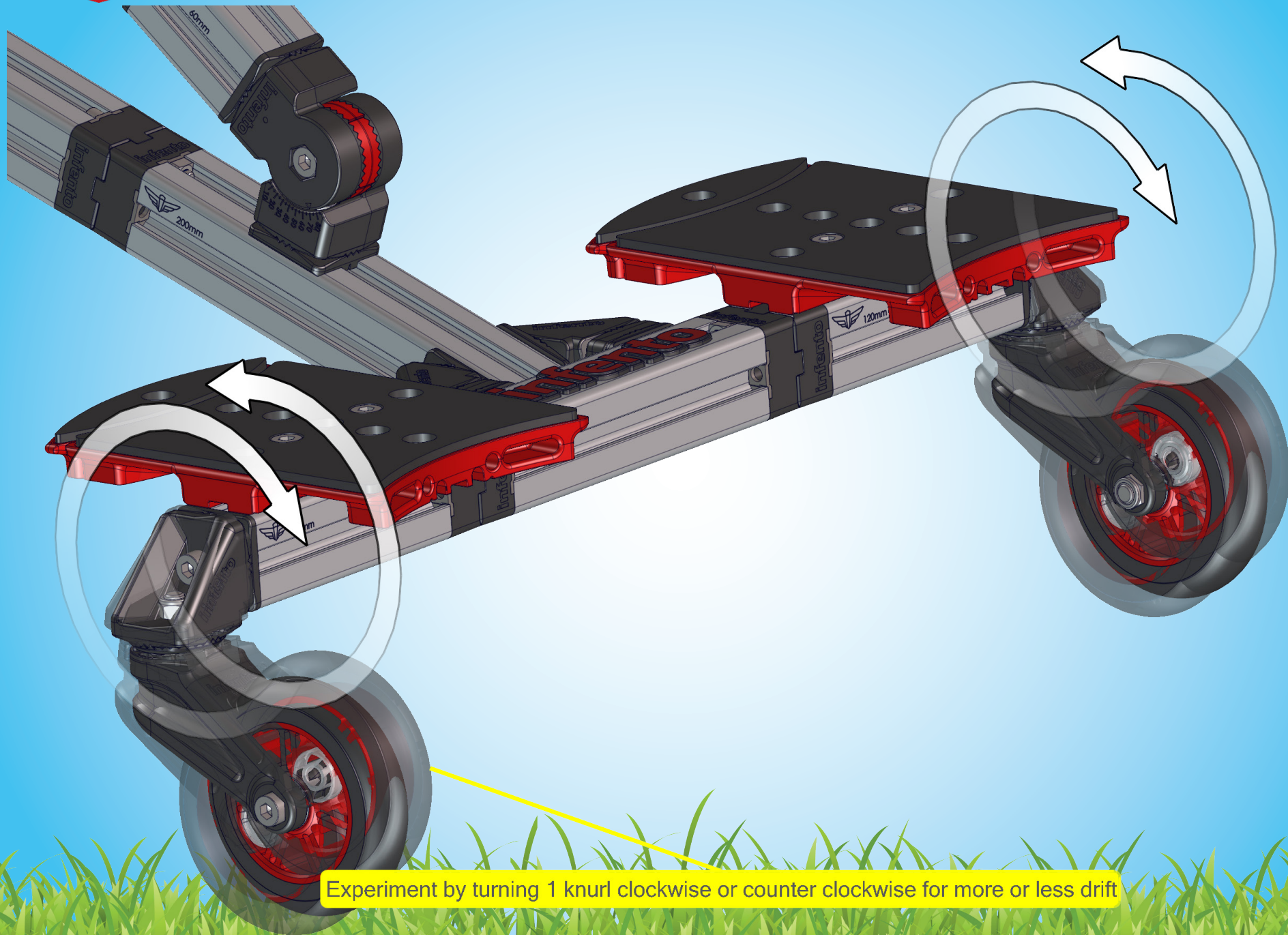

Experiment by turning 1 knurl clockwise or counter clockwise for more or less drift

