



Age 5 - 10



50 kg | 110 lbs



97 cm - 145 cm
38 inch - 57 inch



LEVEL



3 h



E-FLOWMOTION ^{G2}





Profile_320mm

Bolt_M8x25

Profile_240mm

Bolt_M8x25

Use Profile_320 if you are taller than 1,45 meter / 57 inch

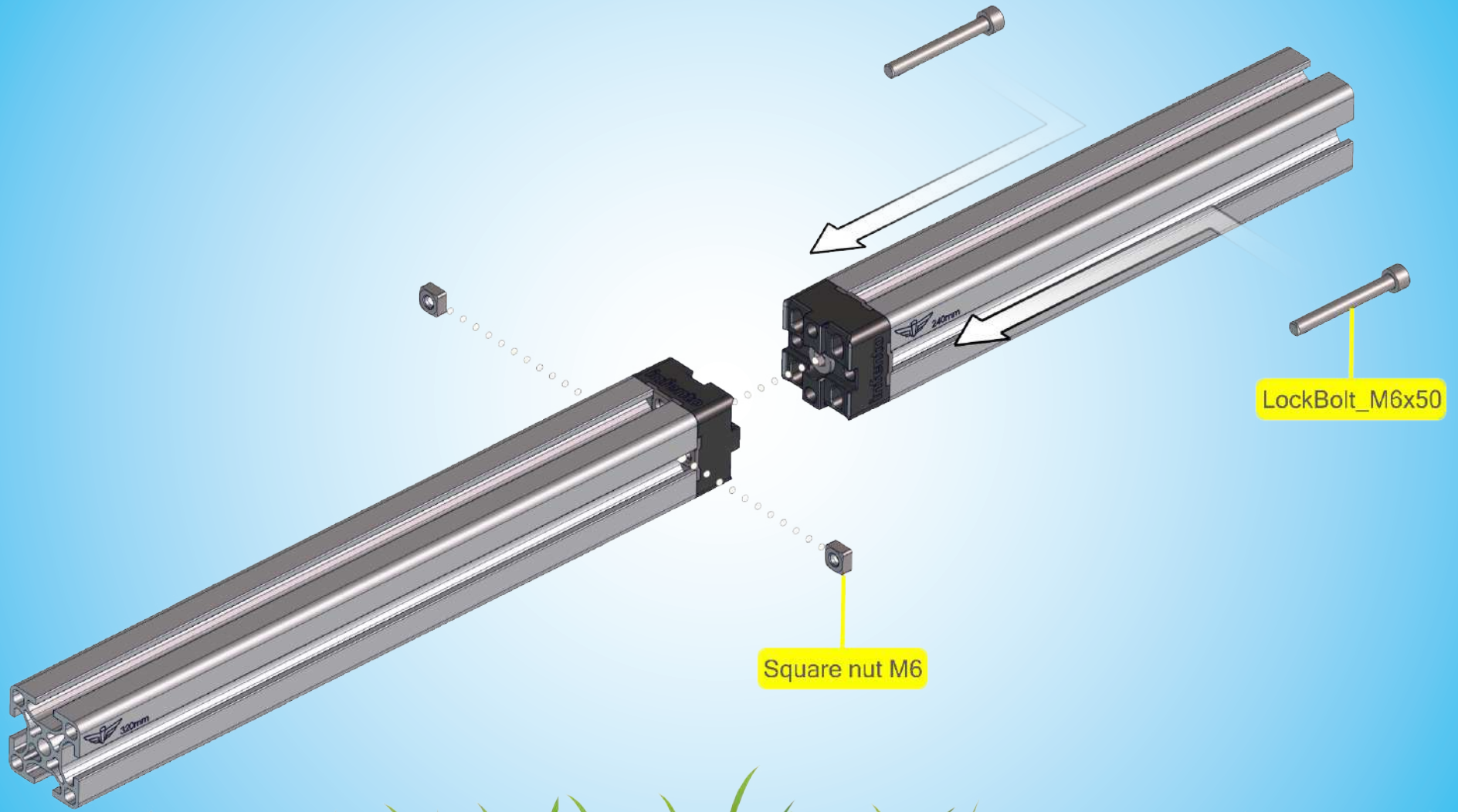

LockBolt_M6x50

Square nut M6

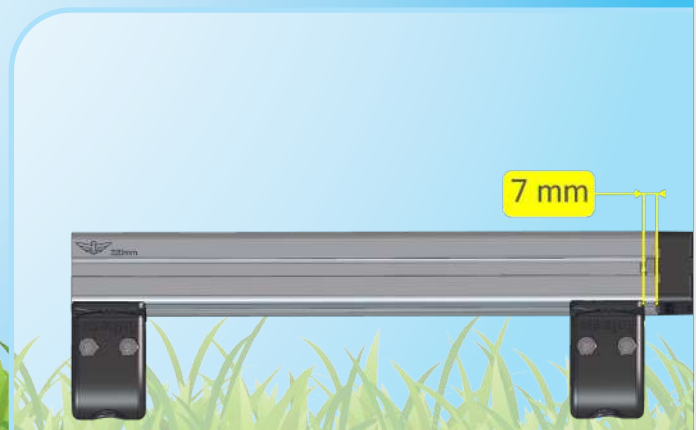



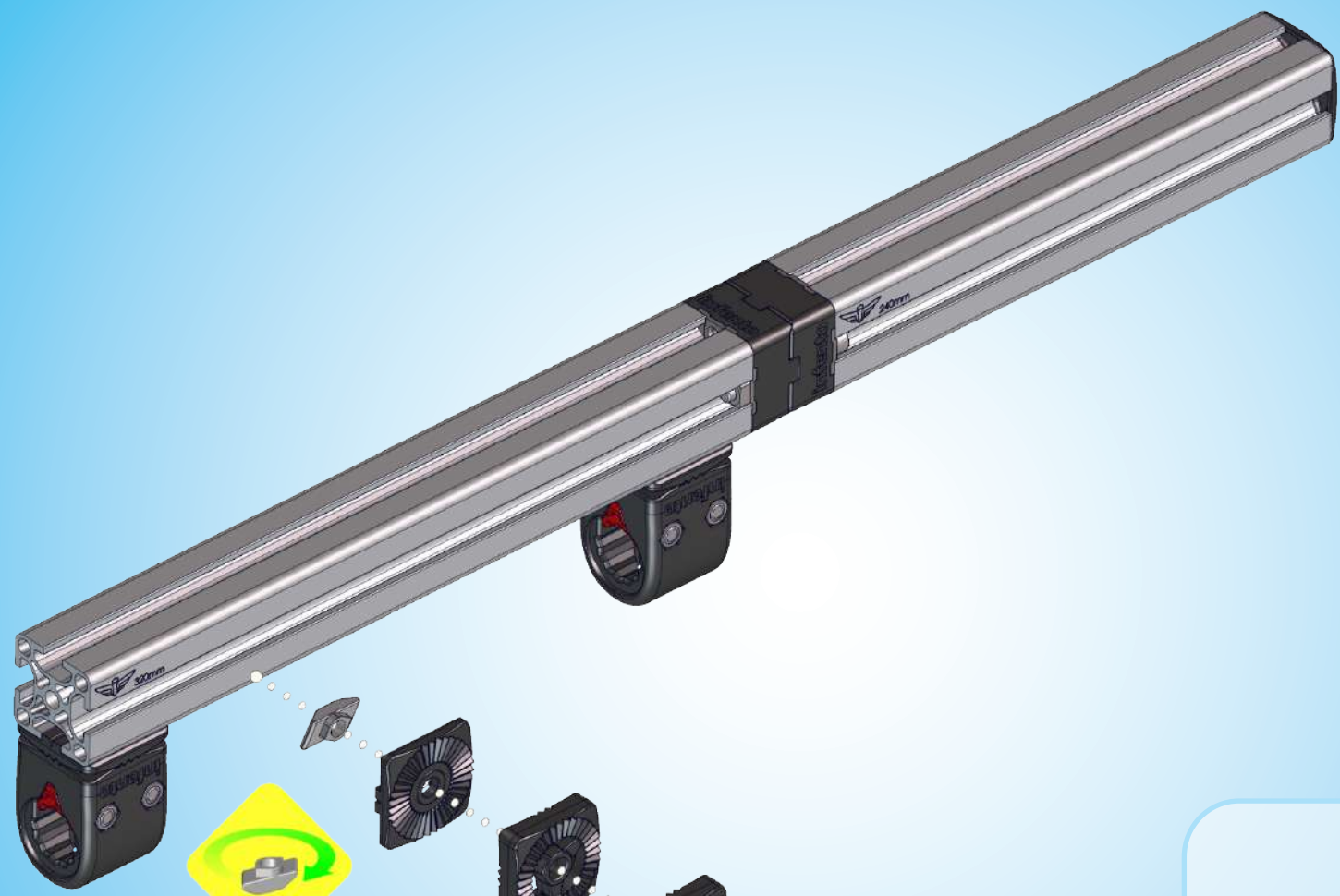

Bolt_M8x40



45 mm





A.8

Bolt_M8x40

25 mm

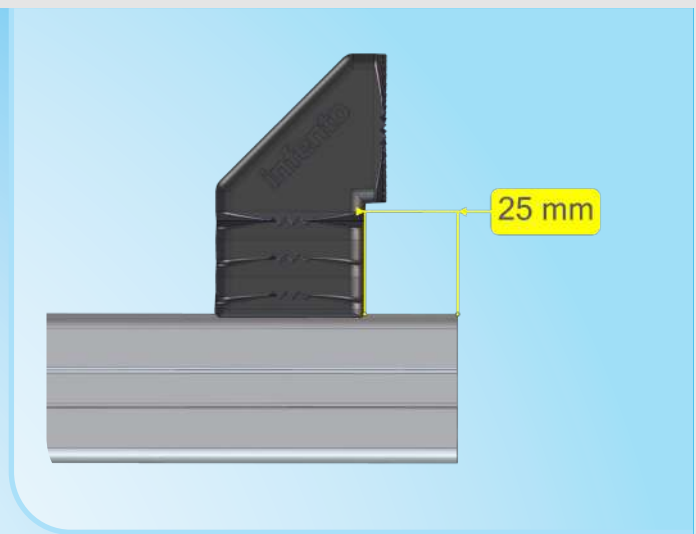
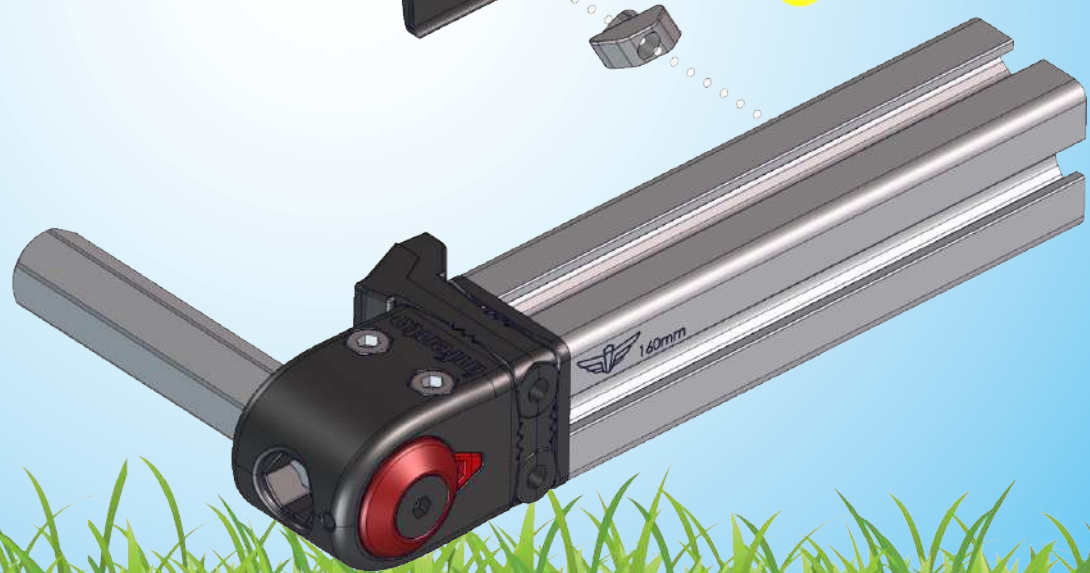



Bolt_M8x25

Bolt_M8x45



Bolt_M8x55

Bolt_M8x55

1

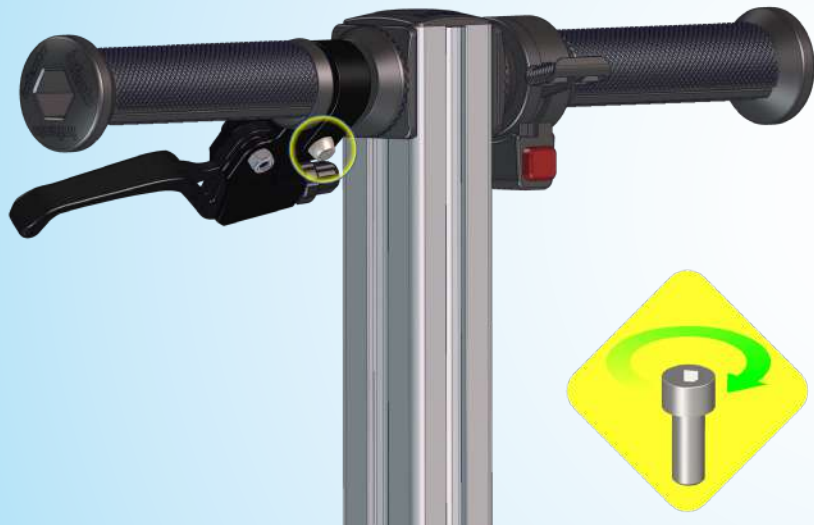

2

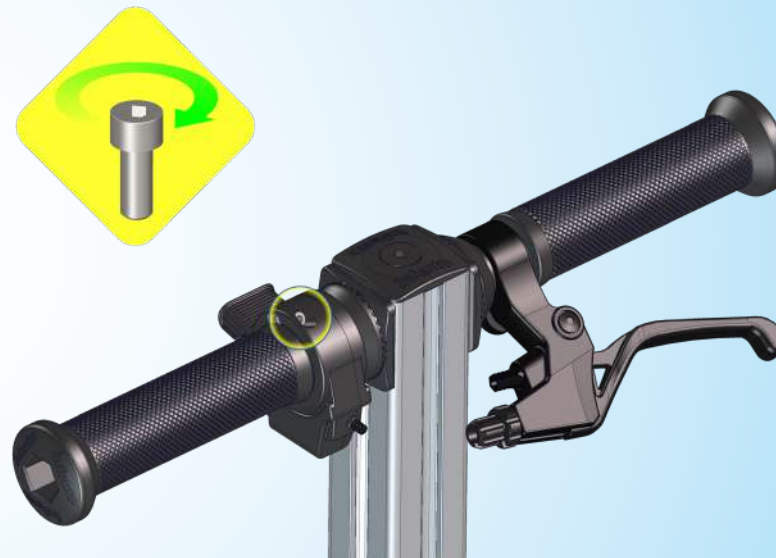

Locknut M8

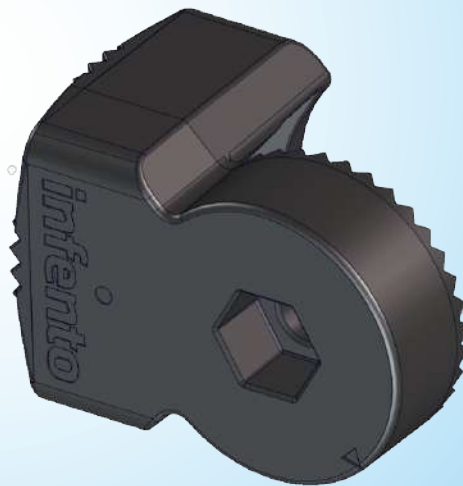
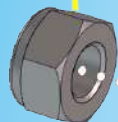

Bolt_M8x25

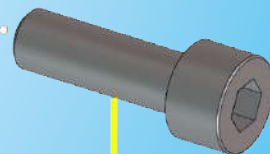



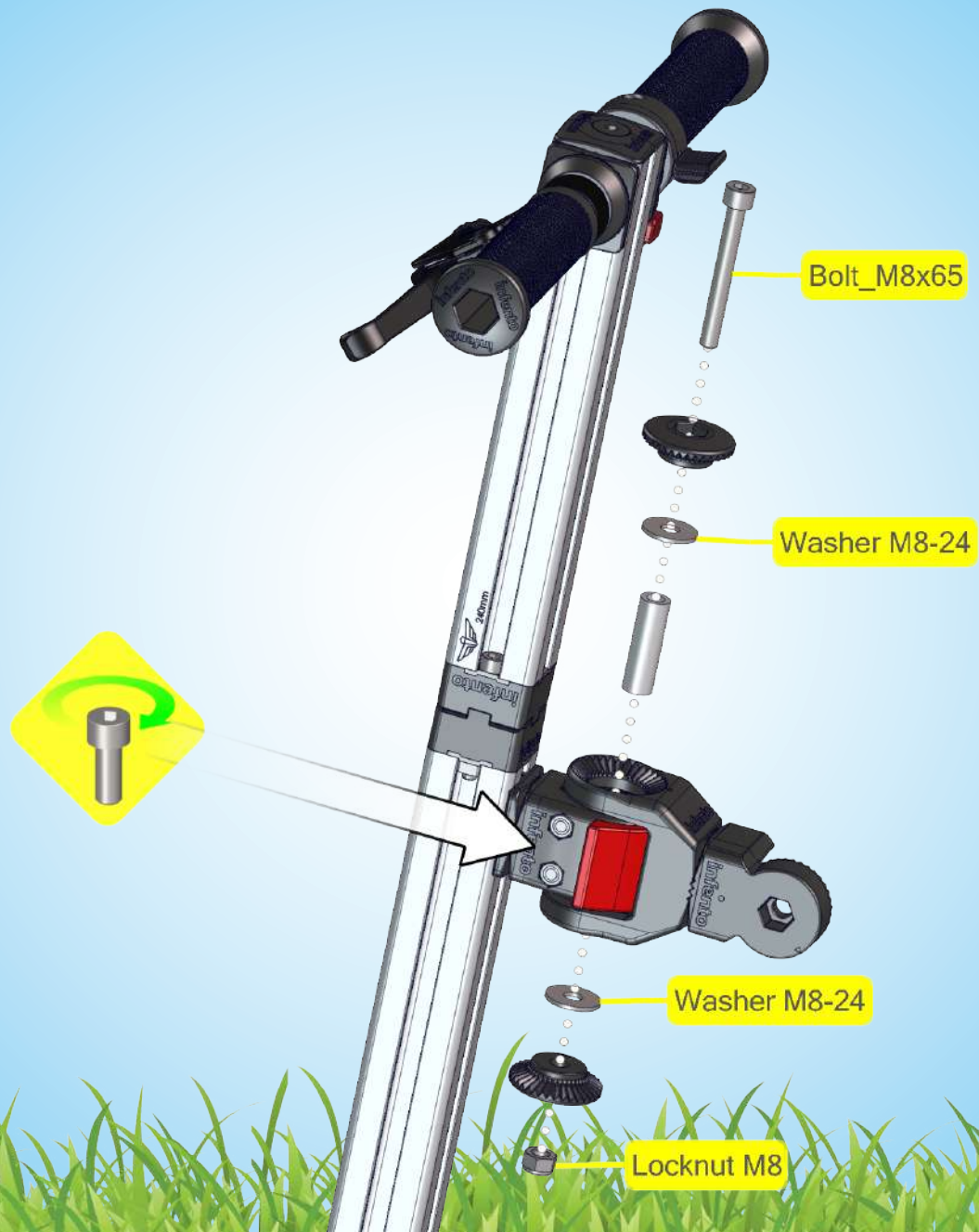

A.15



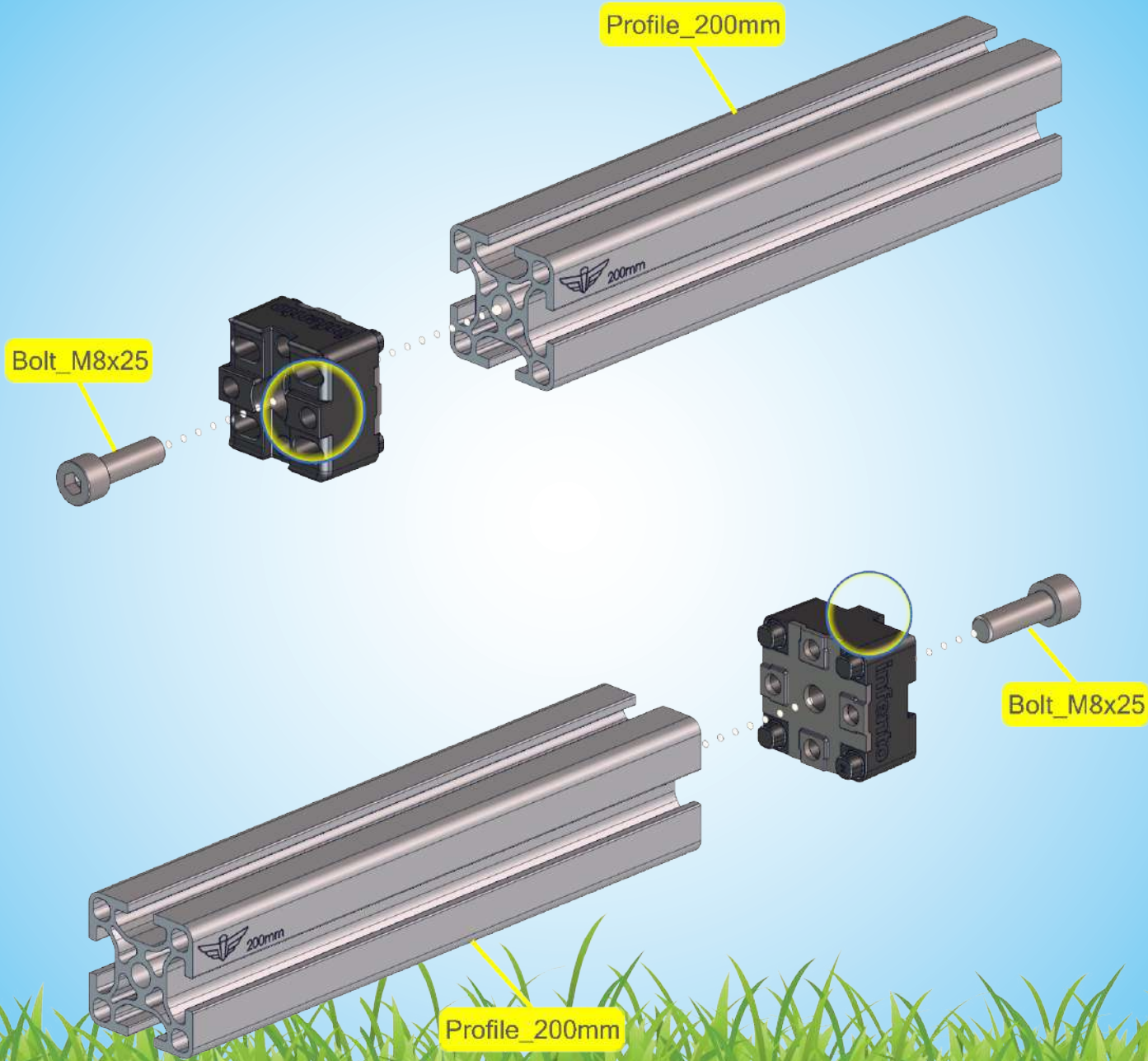

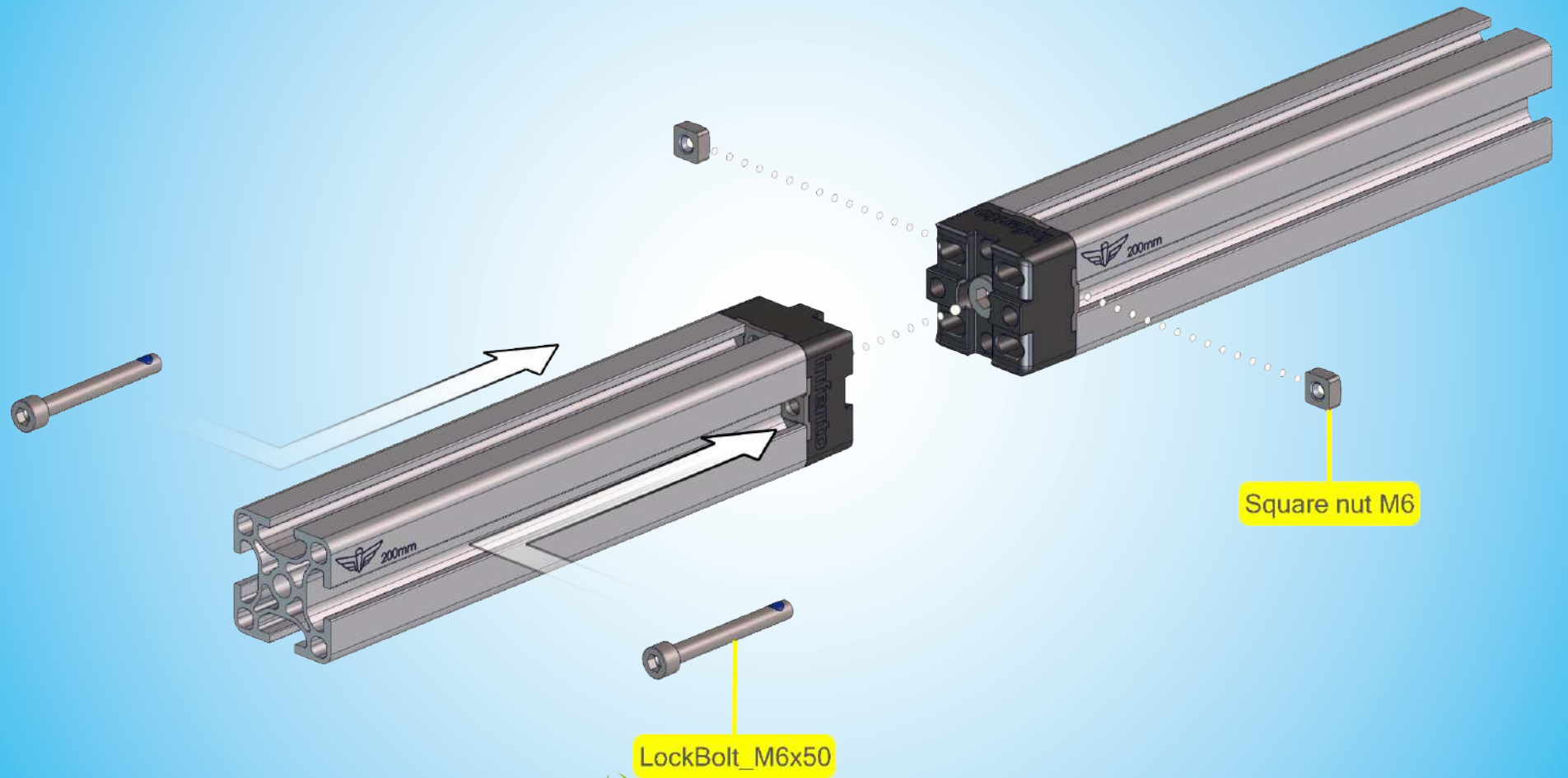

Square nut M6

LockBolt_M6x50

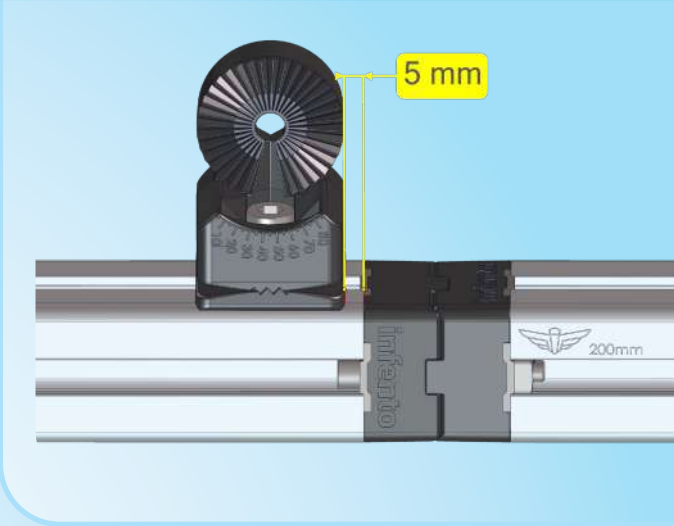

Bolt_M8x20

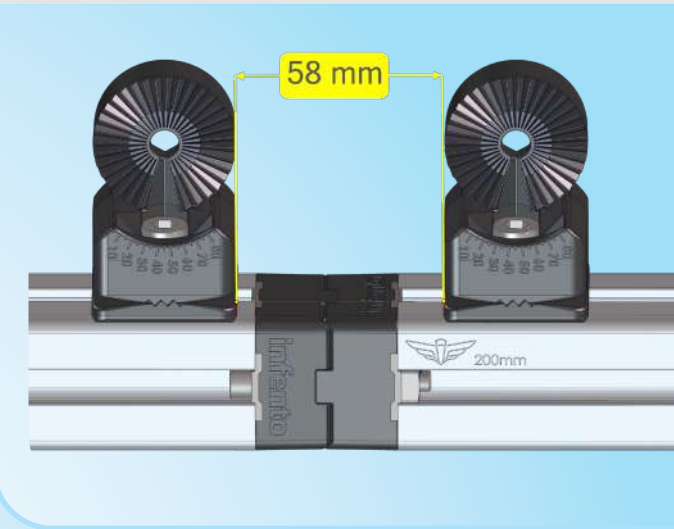
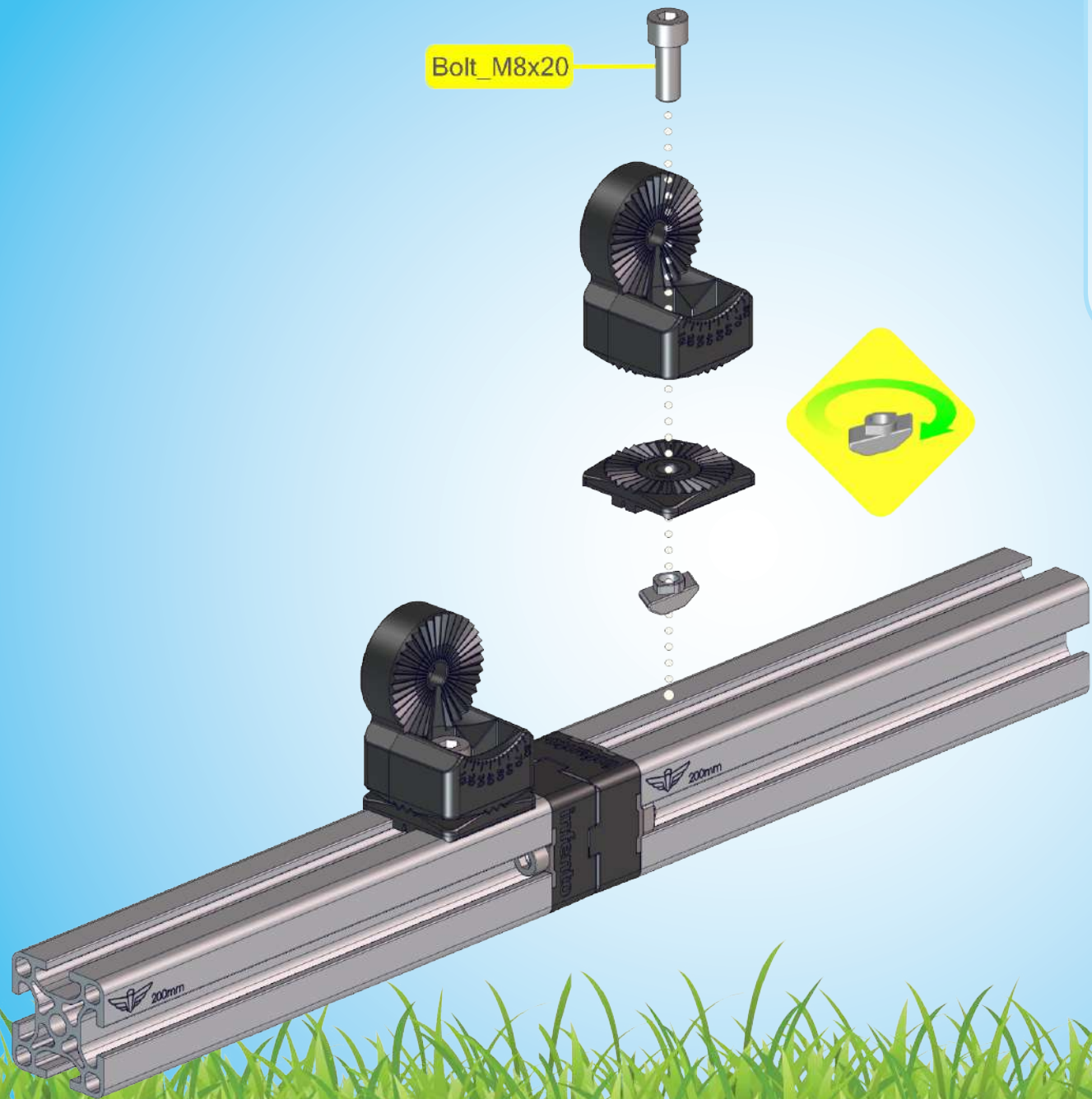



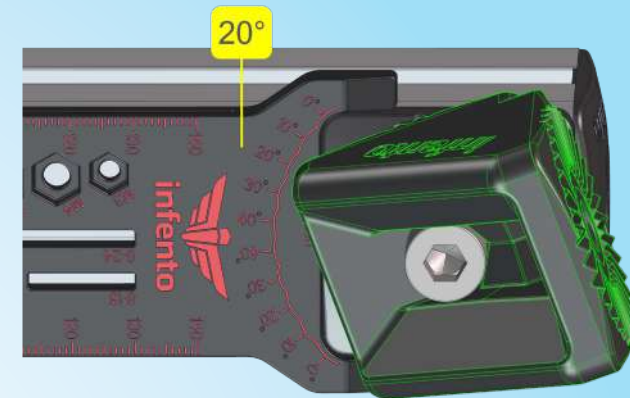

B.7

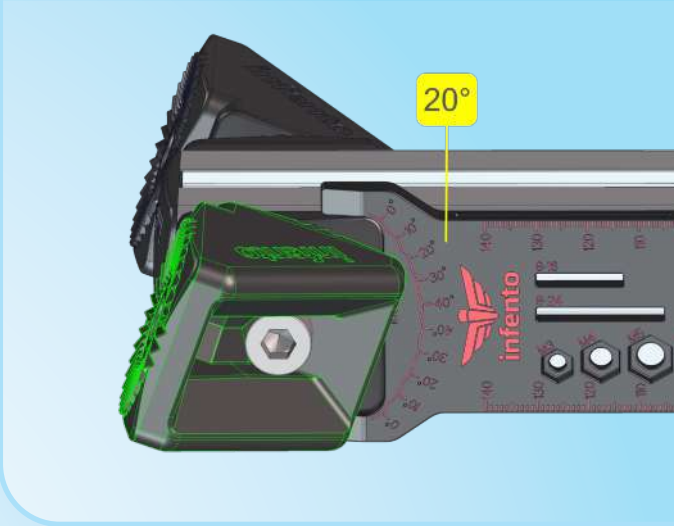
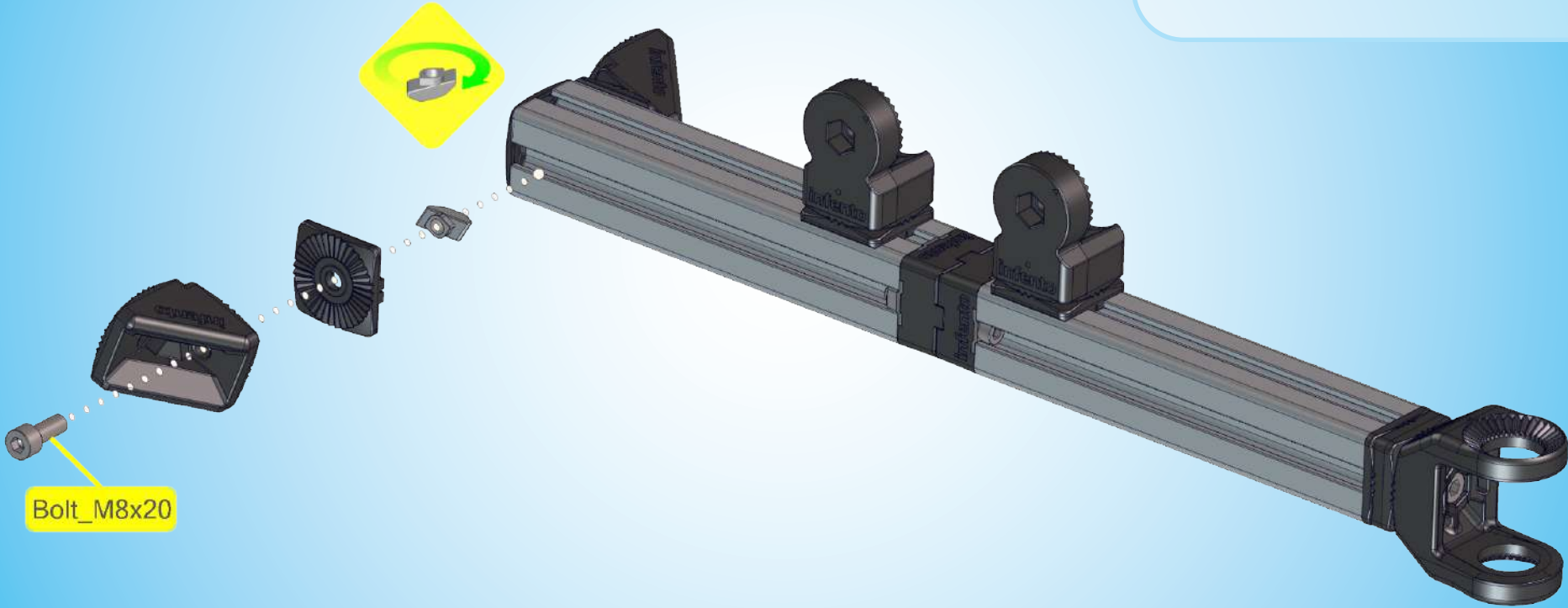

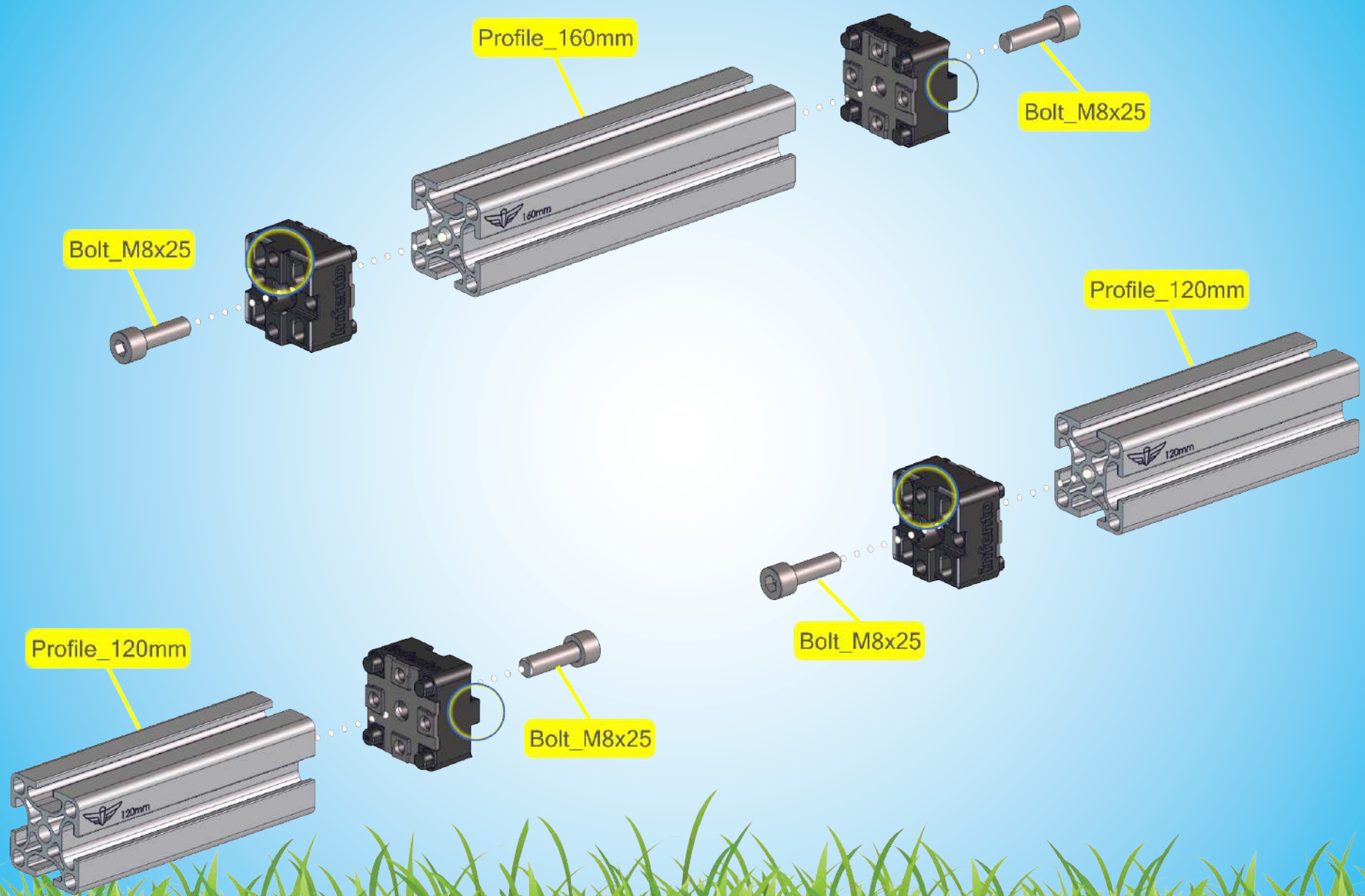

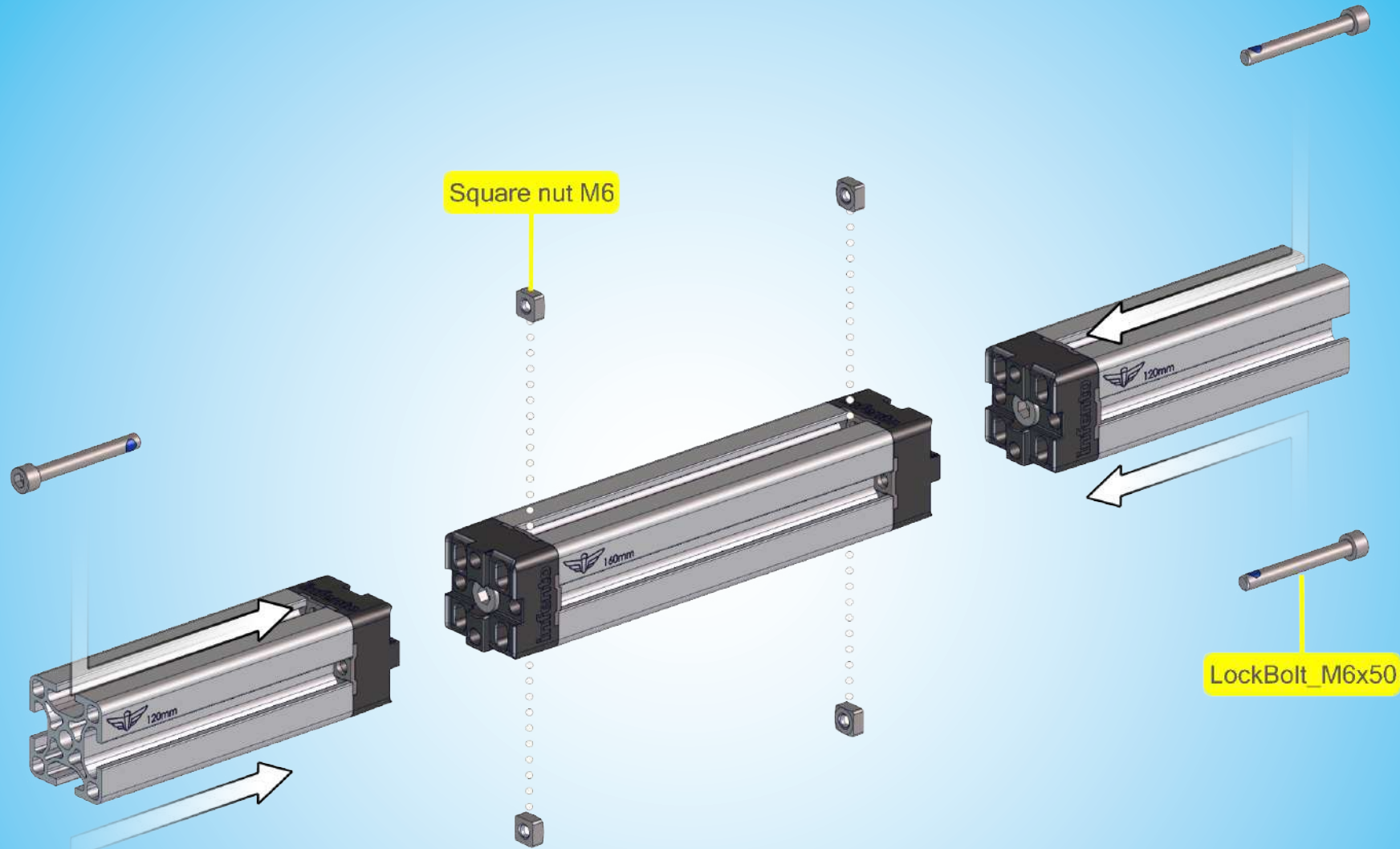

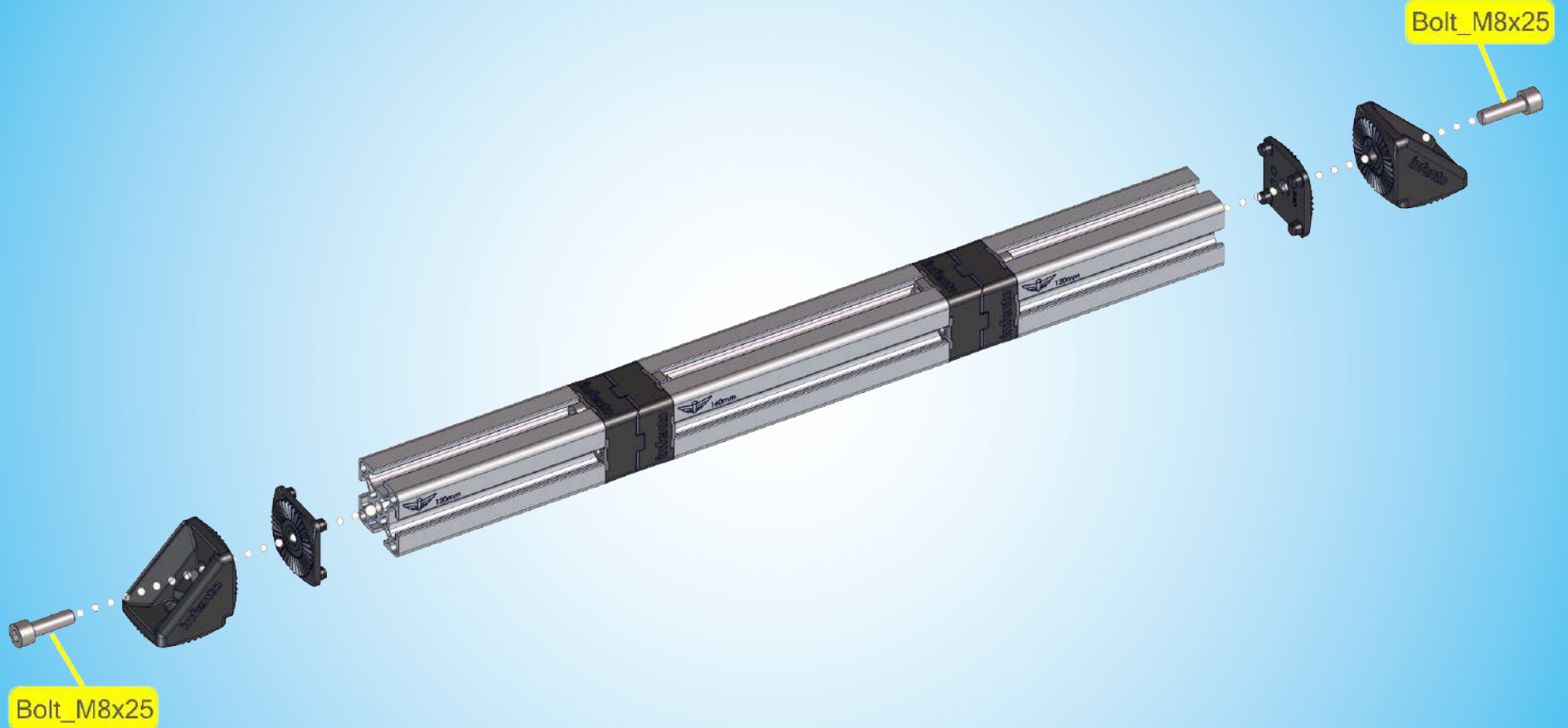

Bolt_M8x25

Bolt_M8x25

infento

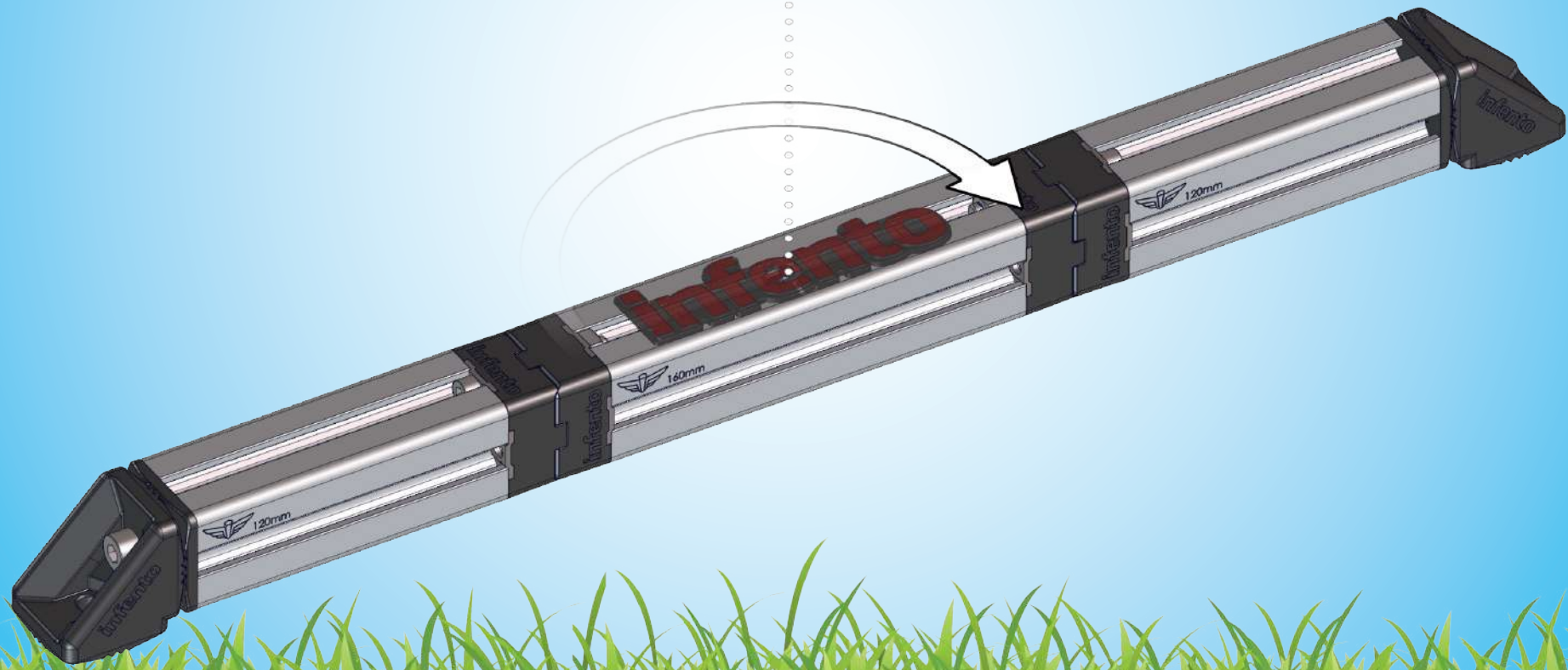

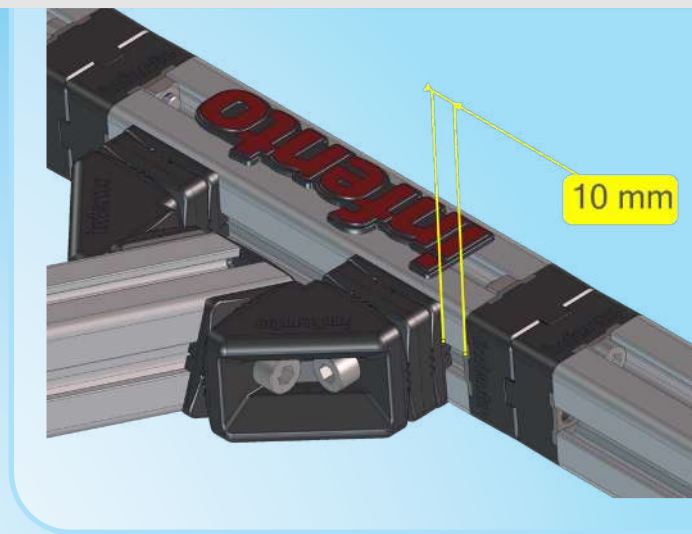



Locknut M8

Bolt_M8x45

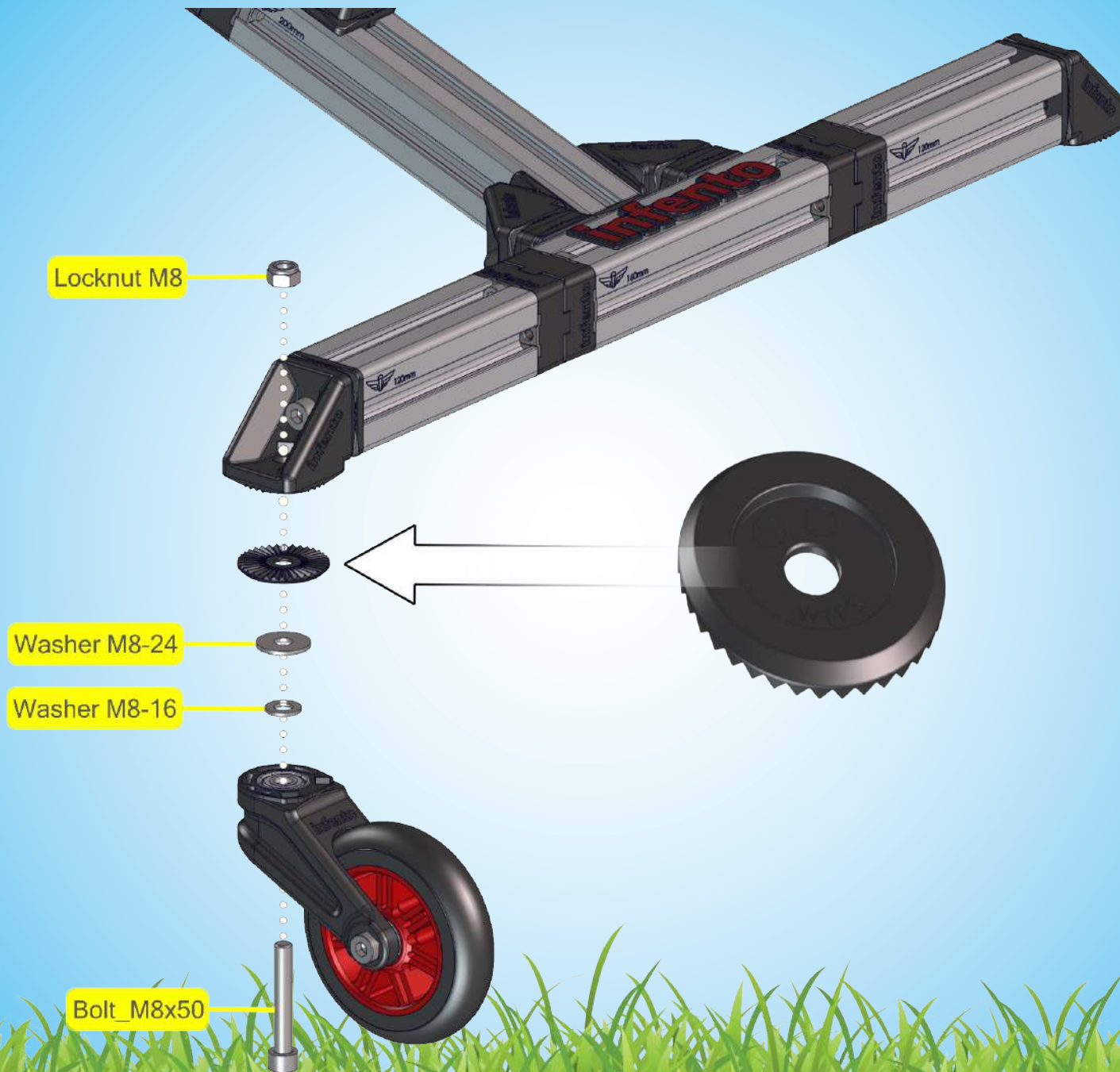



Locknut M8

Bolt_M8x45

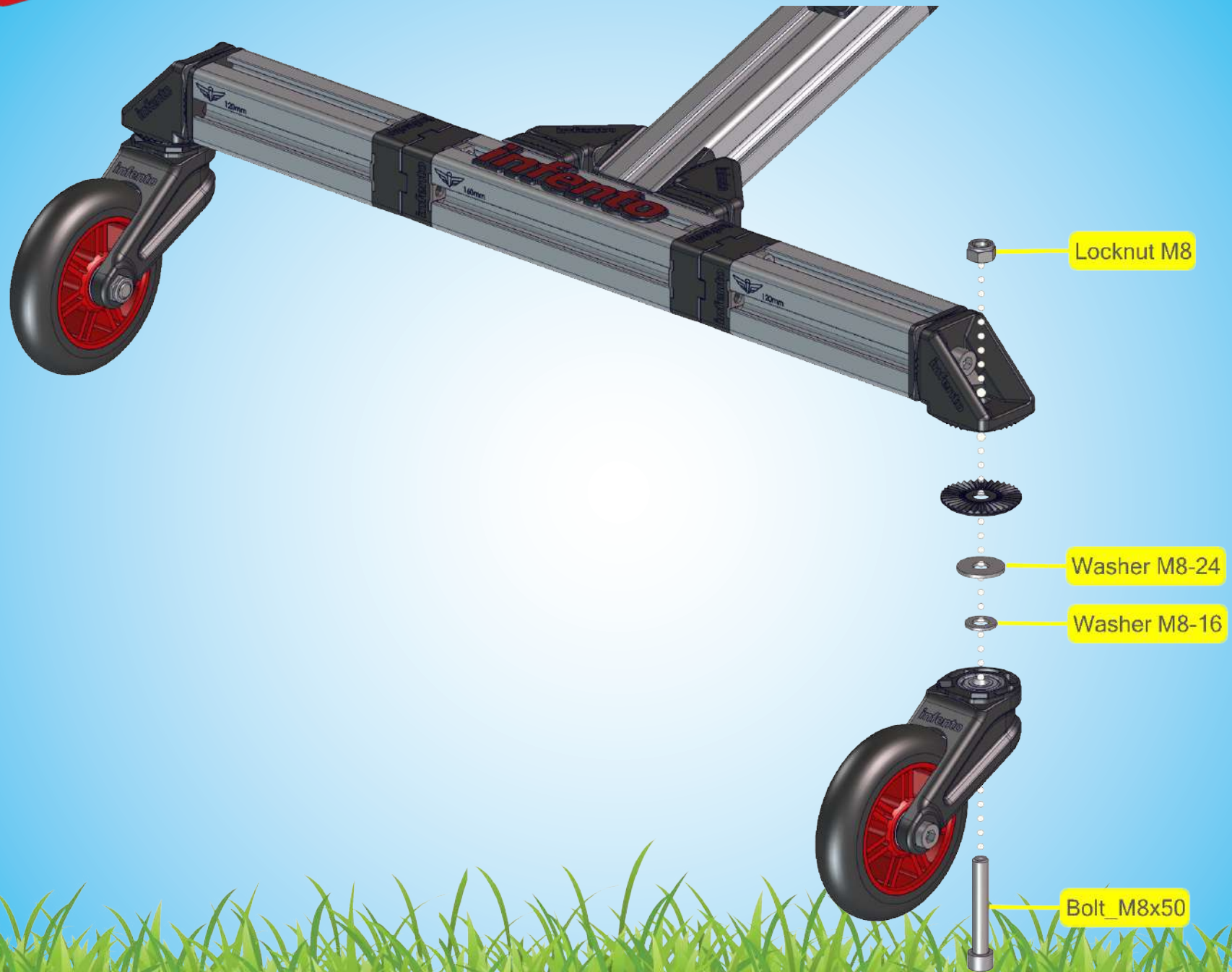



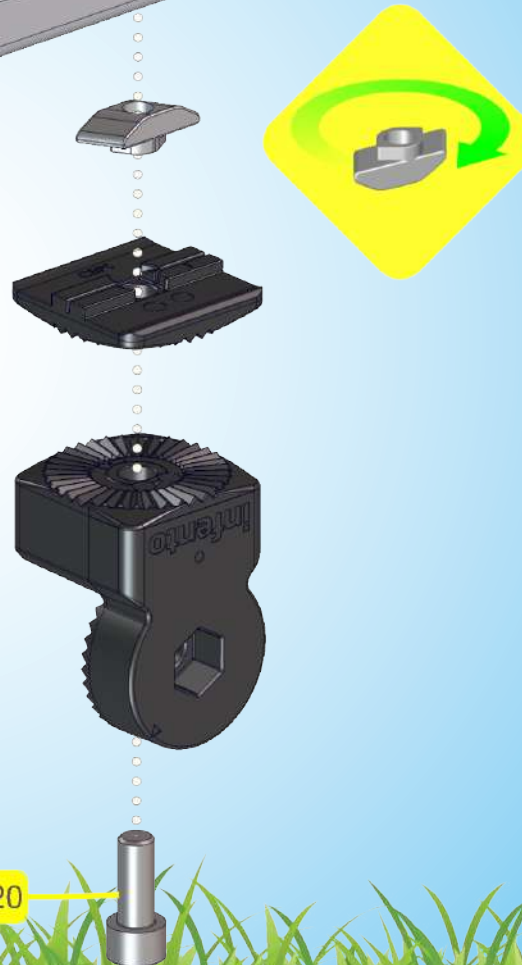
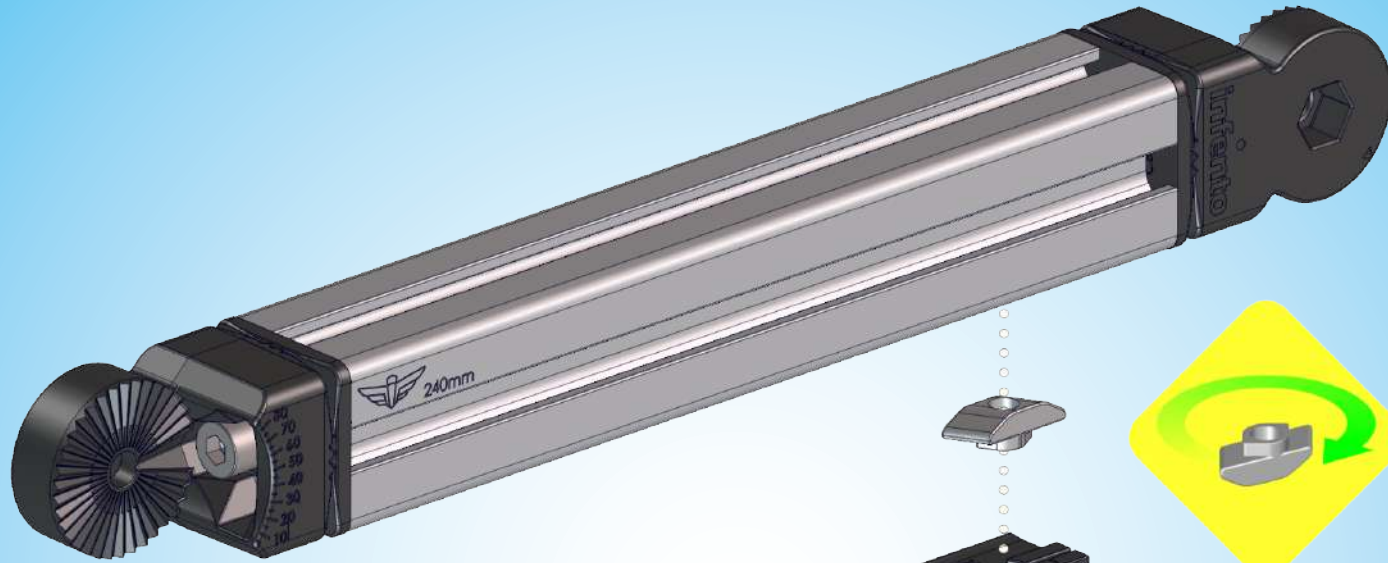

12 mm

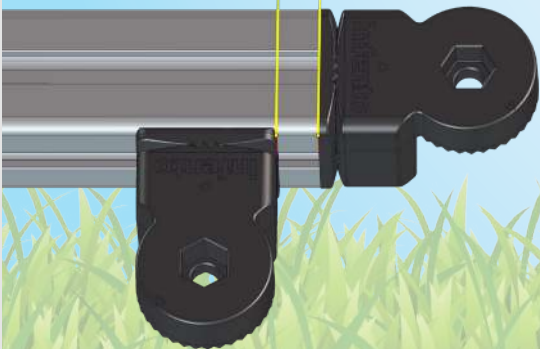

Bolt_M8x20



2x

LockBolt_M6x50

Square nut M6

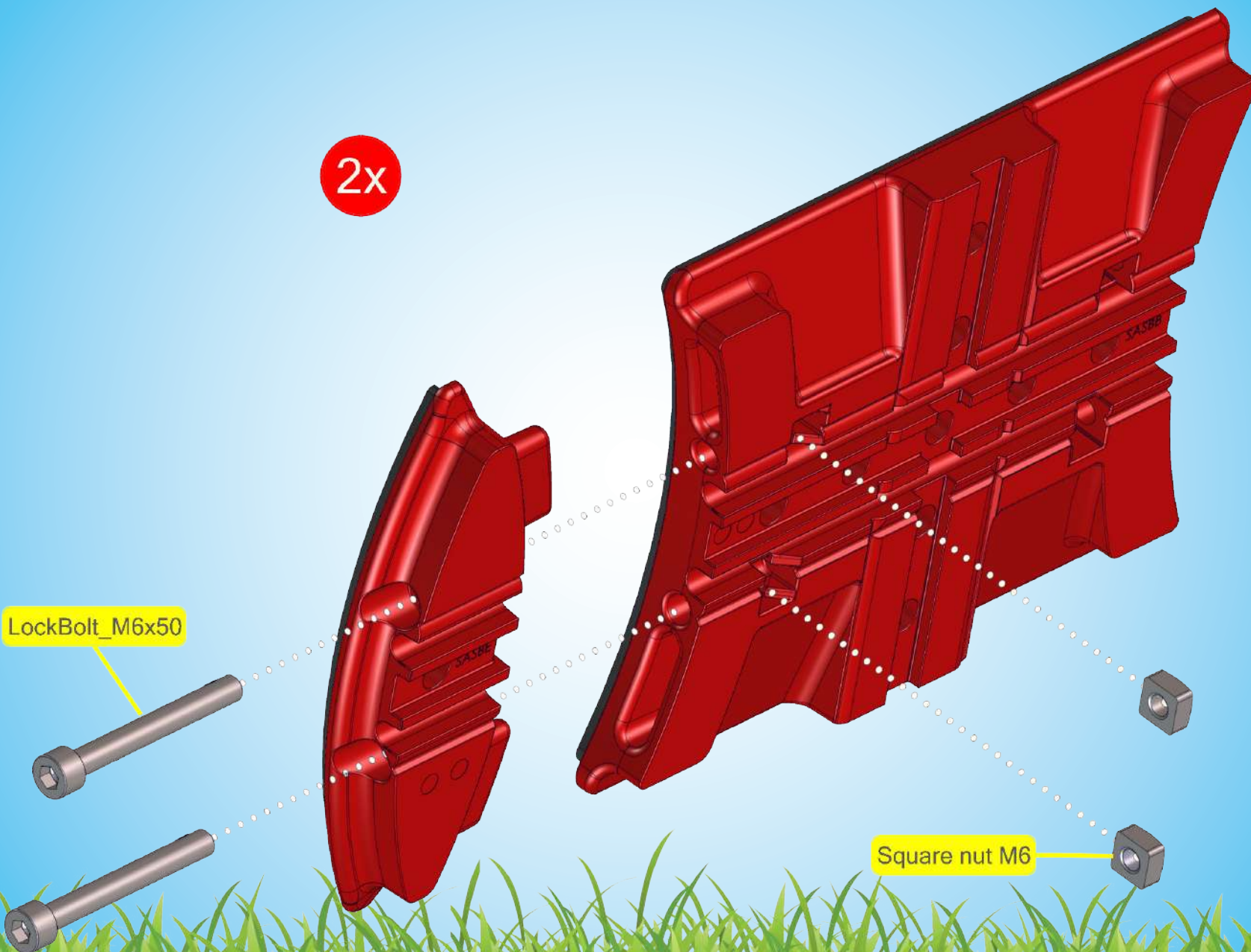

Bolt_M8x20

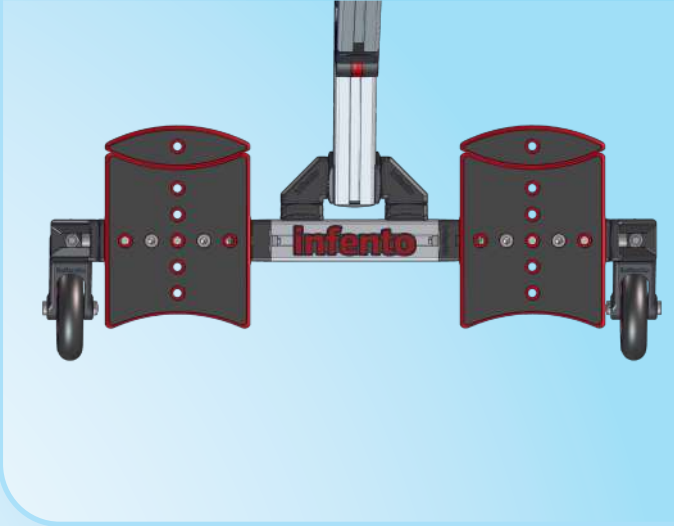



C.1





Bolt_M8x65

Washer M8-24

Washer M8-24

Locknut M8



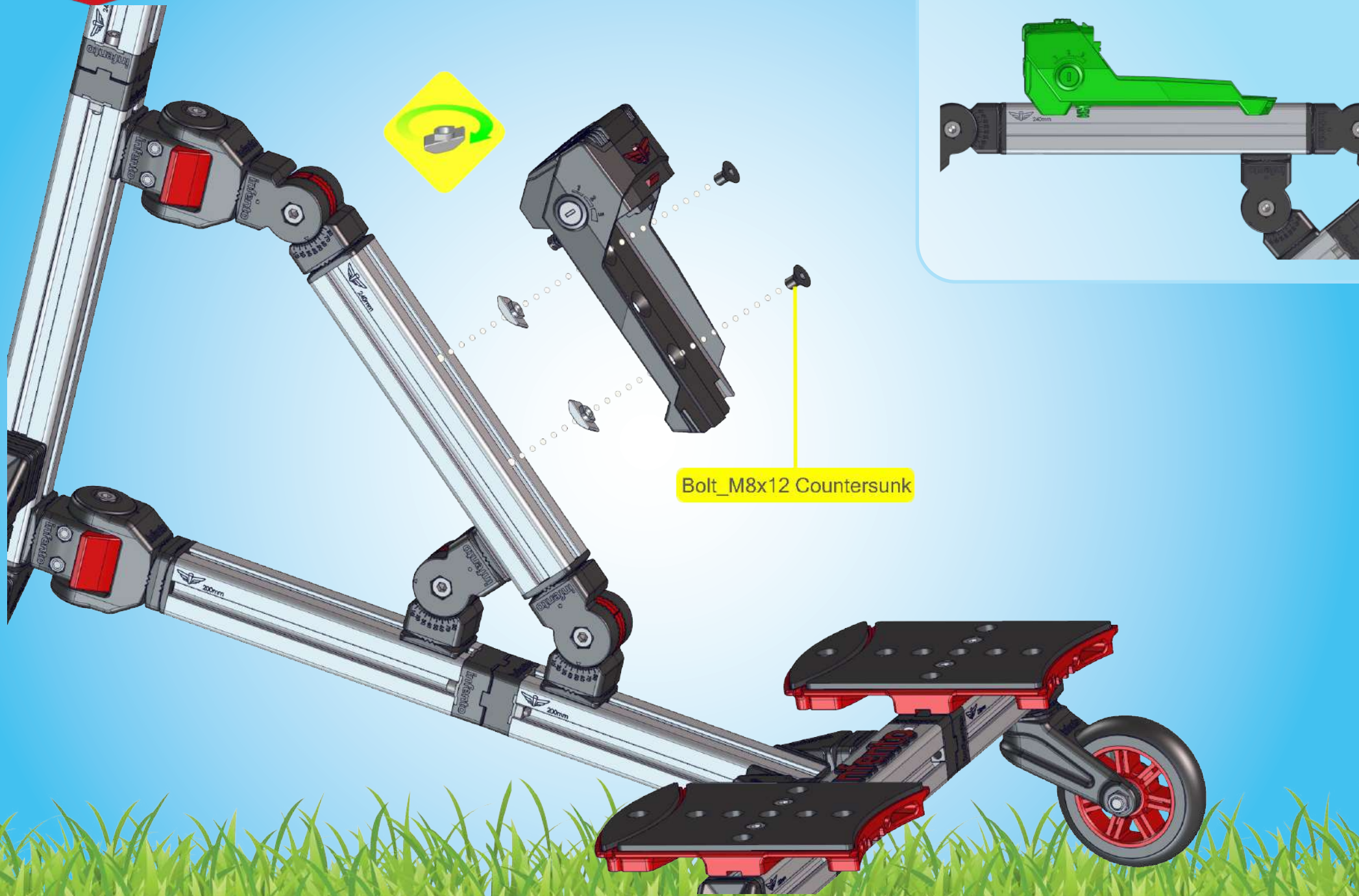

Bolt_M8x12 Countersunk

1

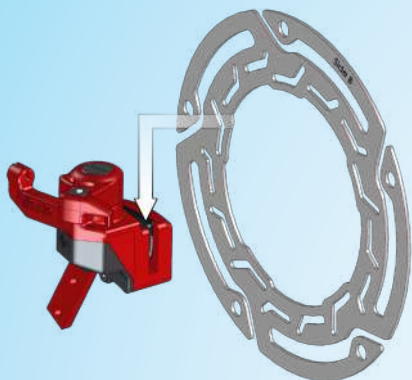

2

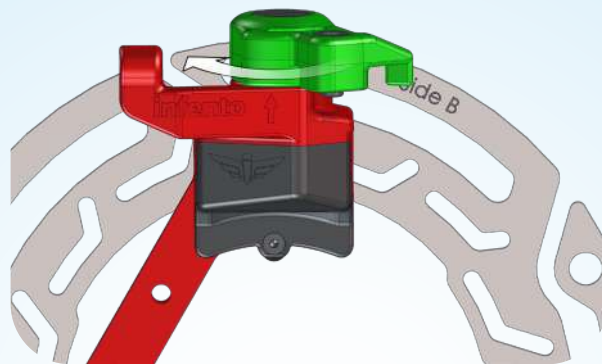

3

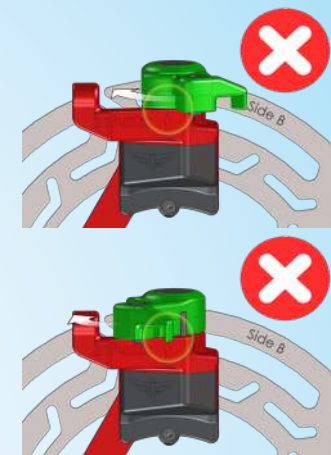

4

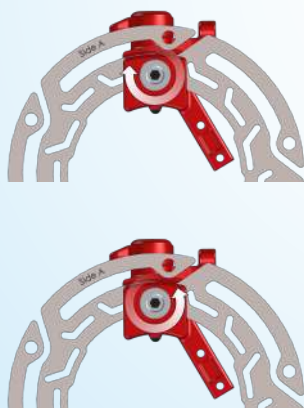

5

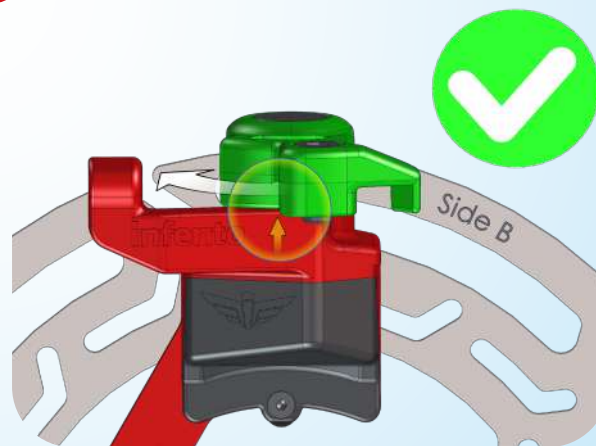

1



2

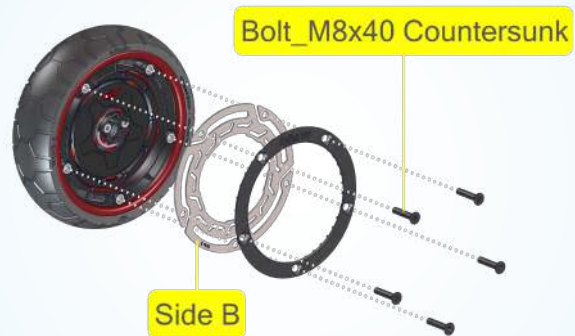

3



C.7

Bolt_M8x20

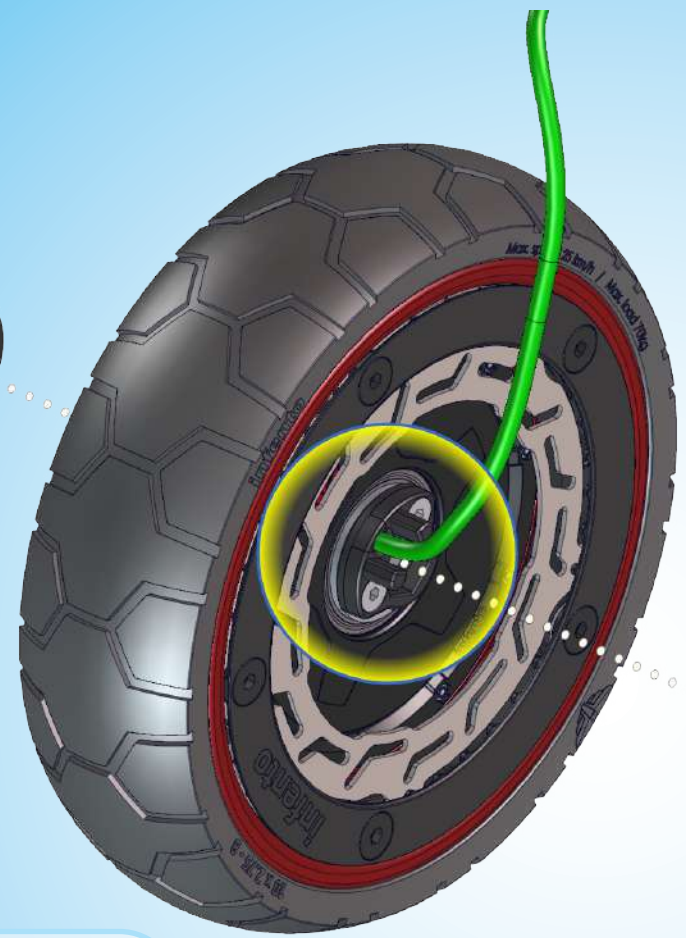

Spacer 20mm

Spacer 2mm

Spacer 5mm

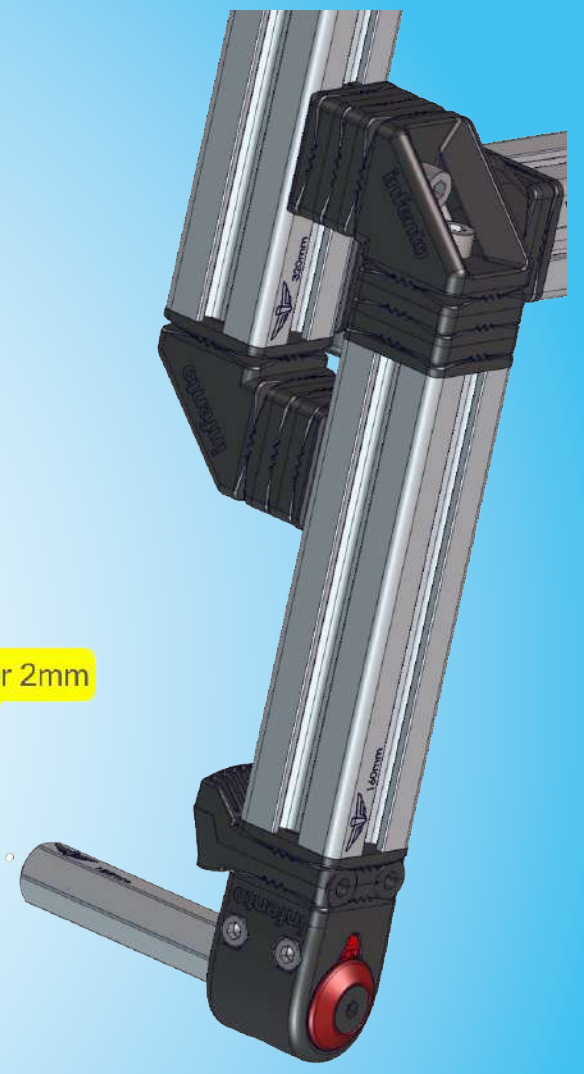

1

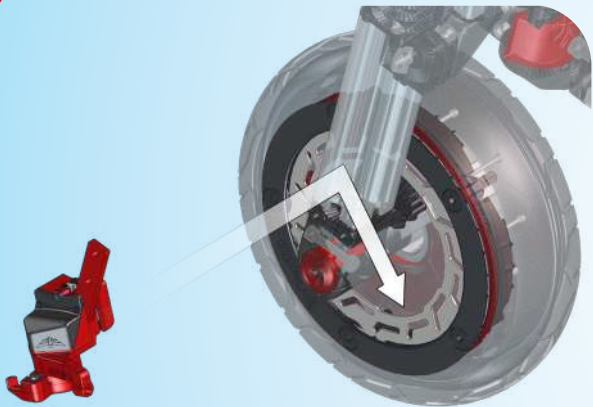

2

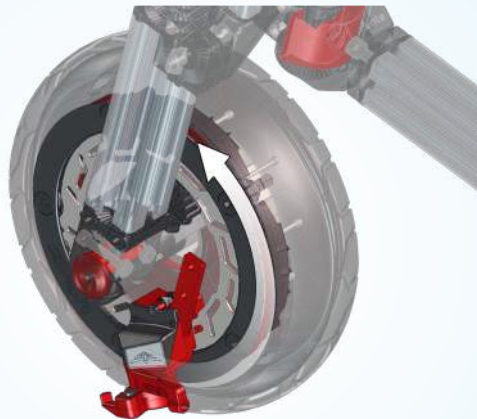

3





Motor cable

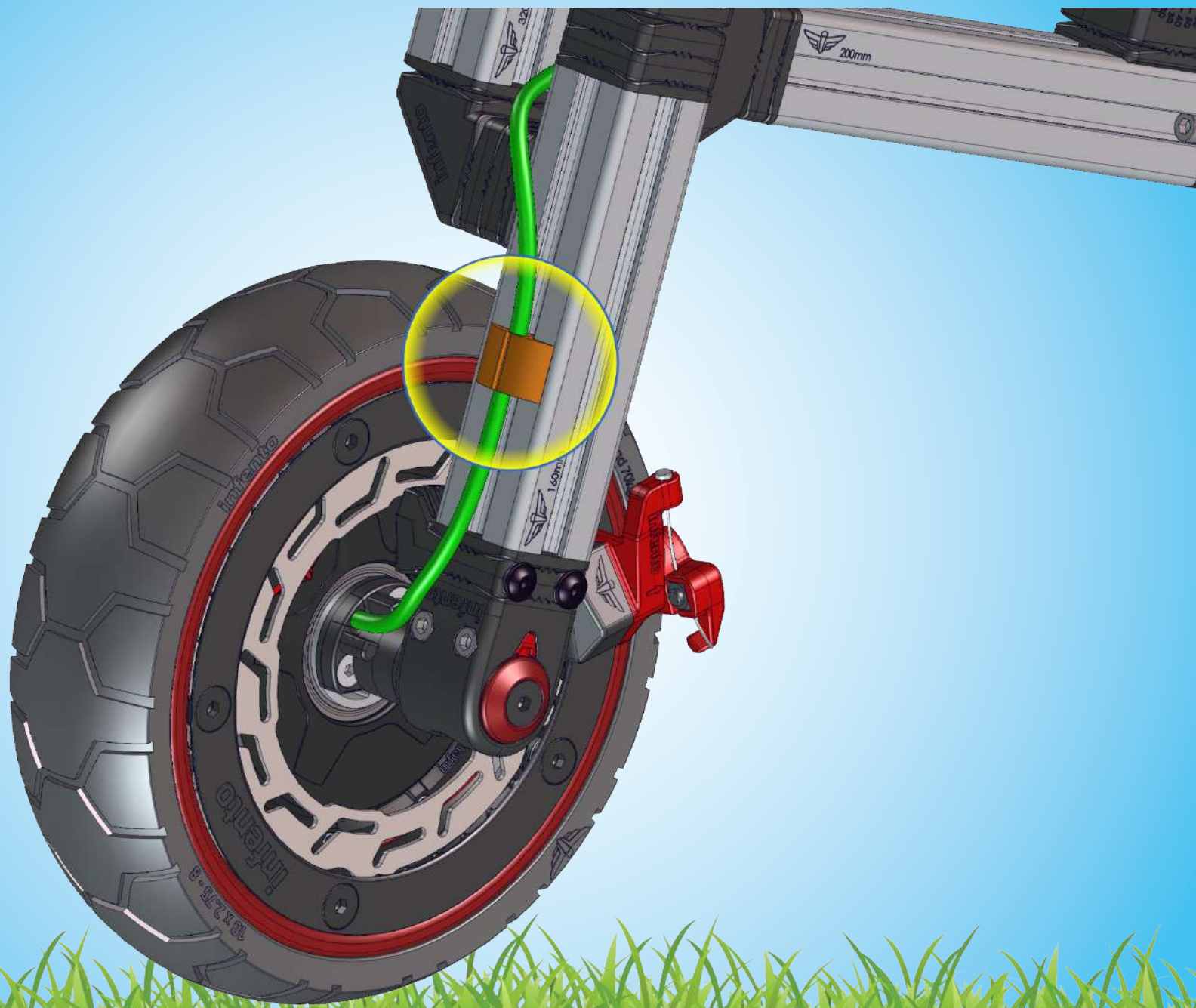



Throttle / brake cable



Brake cable 100 cm



1



2



3



4



5



6





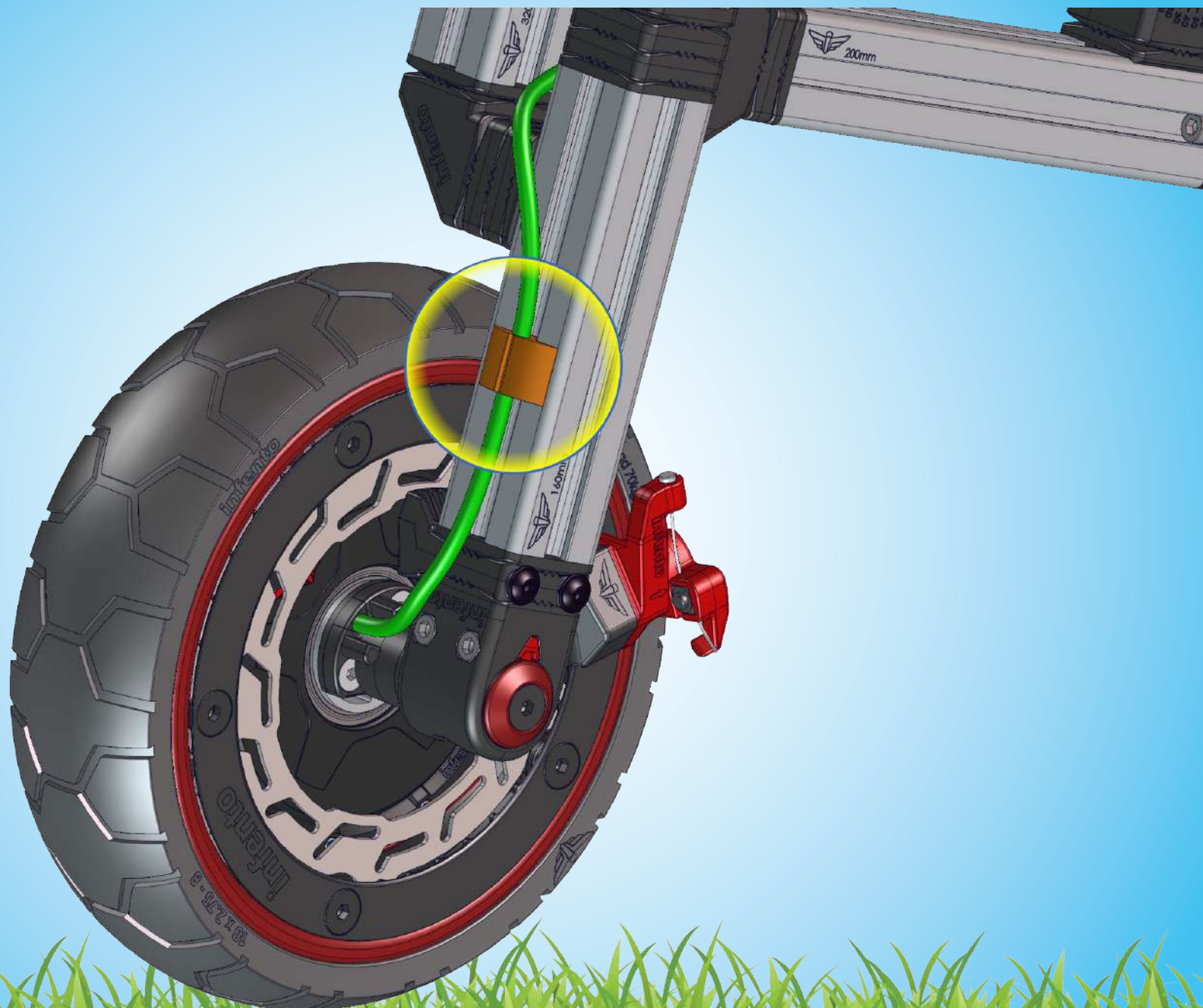

1

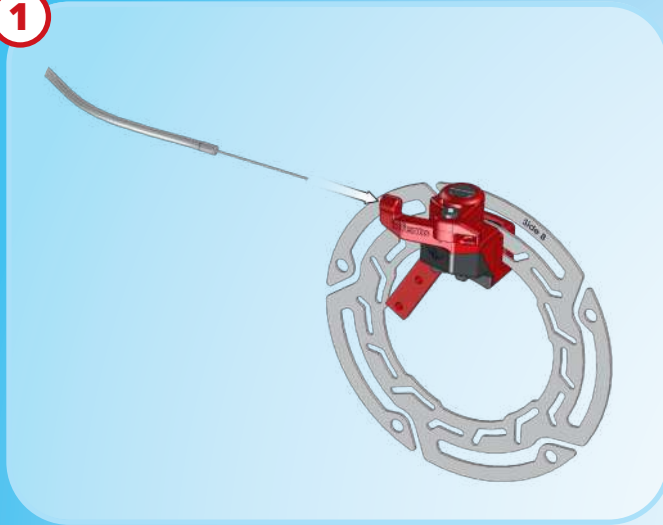

2

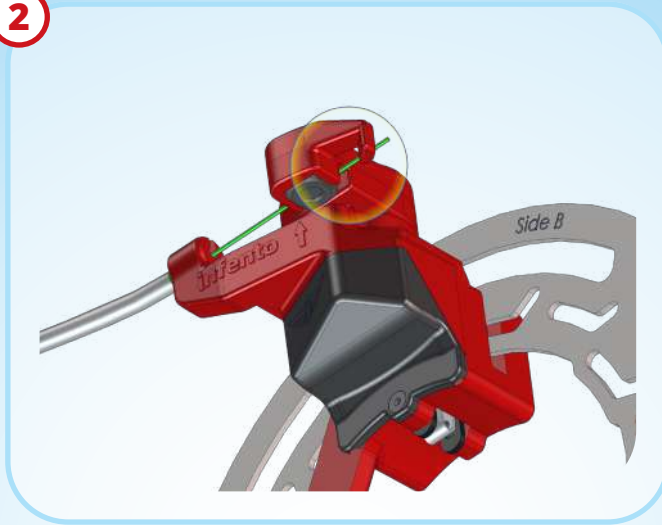

3

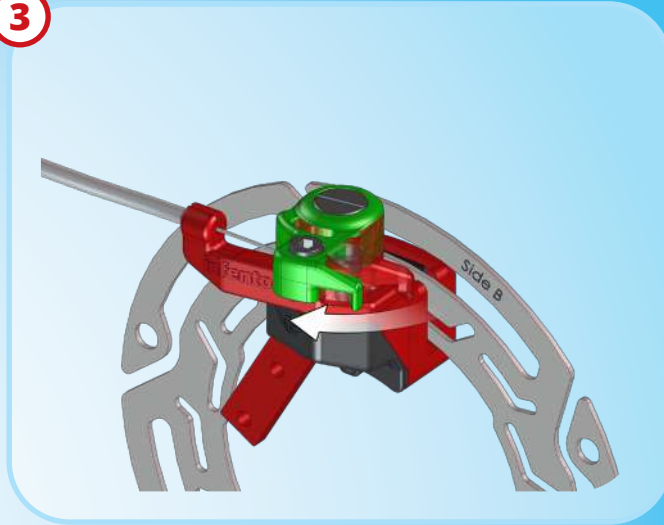

4

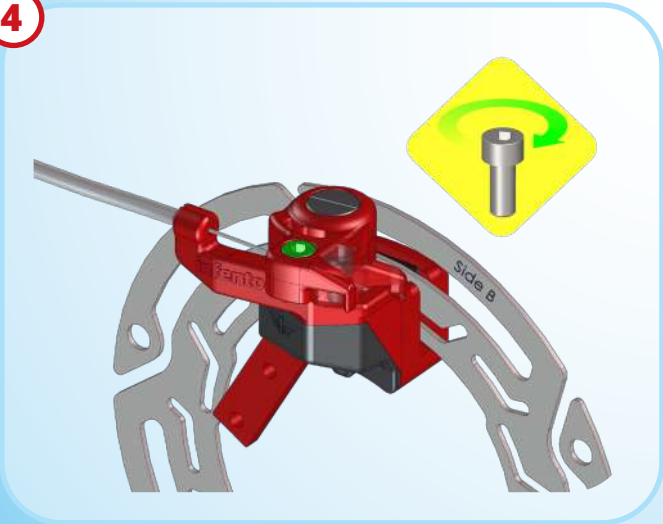

5

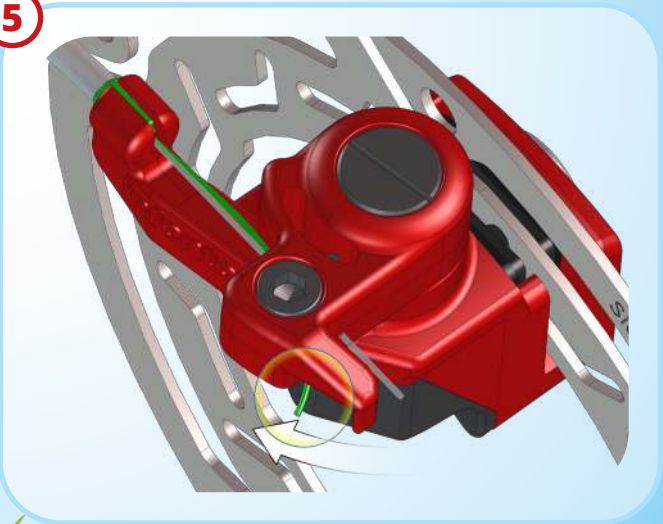



Safety
Check

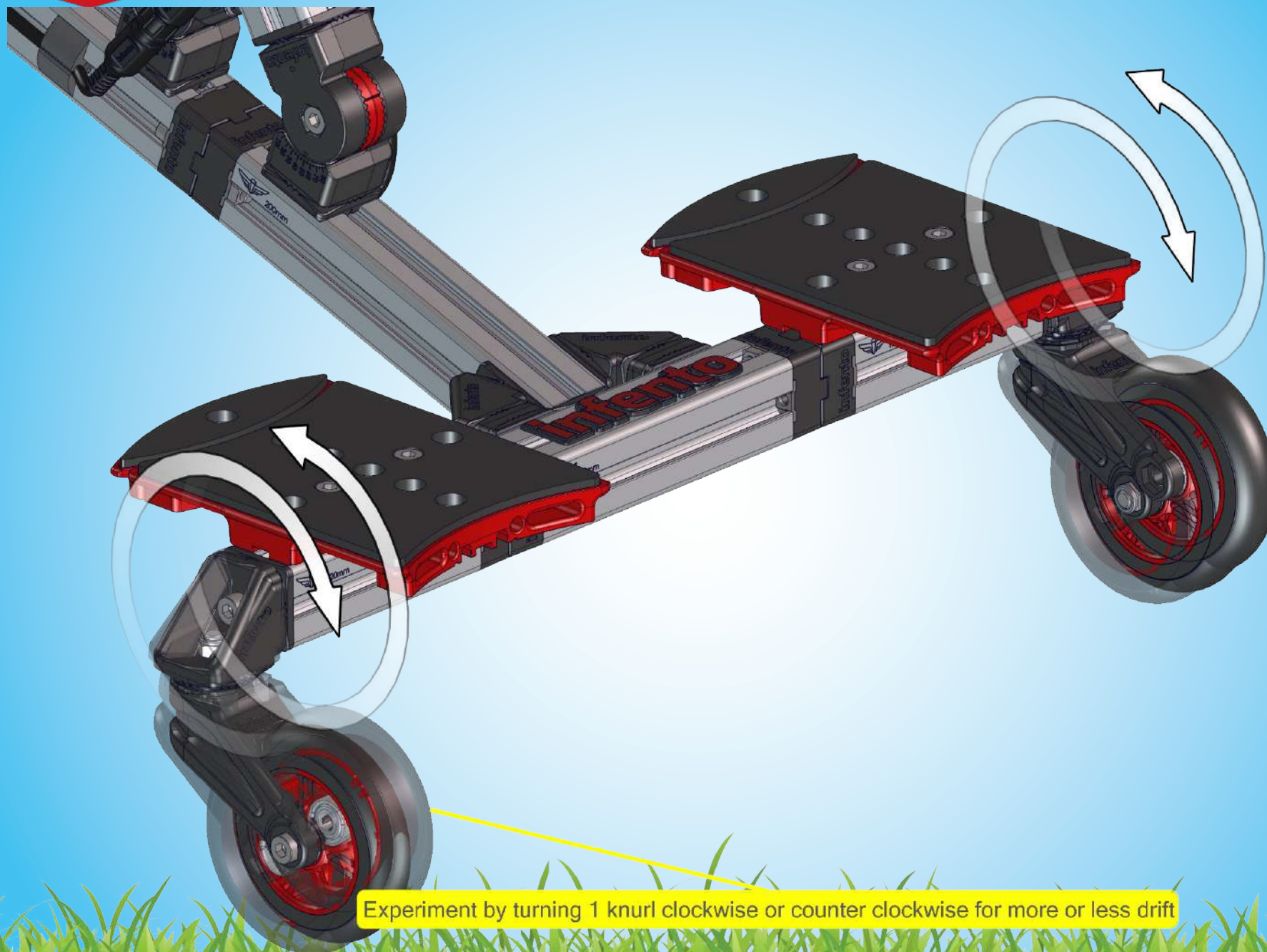

Experiment by turning 1 knurl clockwise or counter clockwise for more or less drift

