

4-9
YEARS

BULLDOG^{G2}

CONSTRUCTION MANUAL



Length 110 - 138 cm / 43-54 inch
Max weight 40kg / 88 lbs
Time to build 6 hours



World's first real constructible rides



WARNING - IMPORTANT NOTICE TO PARENTS

Before you start constructing and use our product, please carefully read the following safety warning and download our manual from our website. This safety warning and manual contains important information relating to your child's safety. It is your responsibility to review this information with your child and make sure they are fully aware of all the warnings before they start riding. Failure to follow instructions and safety precautions can result in serious injury or death.

You can find a digital copy of the manual at the following web address:

www.infentorides.com

PLEASE PRINT OUT THE MANUAL AND KEEP THE MANUAL AND THIS **SAFETY WARNING** IN A SAFE LOCATION FOR FUTURE REFERENCE.

SAFETY SECTION



WARNING! PARENTAL SUPERVISION AND APPROPRIATE USE

Like any moving product, rides made from Infento parts can be dangerous if due care and attention is not paid. To reduce the risk of serious injury: use only under close adult supervision. Parents must review the following warnings and instructions with each Infento ride that is being built. It is your responsibility to review this information and make sure that all riders understand all warnings, cautions, instructions and safety topics, and assure that young riders are able to safely and responsibly use this product. Infento recommends that you periodically review and reinforce the information in this manual with younger riders, and that you inspect and maintain your child's Infento rides to insure their safety.

WARNING! RIDING ON INFENTO RIDES CAN BE A DANGEROUS ACTIVITY

Riding on Infento rides can be a dangerous activity. Certain conditions may cause the equipment to fail without fault of the manufacturer. Rides made from Infento parts can and are intended to move, and it is therefore possible to lose control, fall off and/or get into dangerous situations that no amount of care, instruction or expertise can eliminate. If such things occur you can be seriously injured or die, even when using safety equipment and other precautions. Ride at your own risk and use common sense.

WARNING! NO LIABILITY FOR CONSTRUCTED RIDES THAT DIFFER FROM OUR MANUALS

The rides that you can find in our manuals have been tested by official independent testing agencies. We will not be responsible or liable, directly or indirectly, in any way for any loss or damage of any kind incurred as a result of your decision to build constructions or rides that differ from the official rides that we show in our manuals.

ASSEMBLY – SUBSECTION

WARNING! OUR KITS CONTAIN SMALL PARTS

This package contains small parts which, before assembly, present a choking hazard to children under the age of three. Care should be taken

during unpacking and assembly to insure that all small parts and plastic bags are accounted for and kept out of the reach of children.

WARNING! TO AVOID SERIOUS INJURY:

1. Construction/assembly of a ride should always be under supervision of an adult using the Infento manual for the specific ride.
2. All fasteners (bolts and nuts) should be fully tightened.
3. It is the responsibility of the adult who assembles this bicycle to properly install all parts included in the factory sealed shipping carton and to make the adjustments to the functional parts such as handle bar and seat and chain when necessary.

USE – SUBSECTION

WARNING! TO AVOID SERIOUS INJURY:

1. Continuous adult supervision is required.
2. Only ride constructed rides that have been built according to the instructions given in the official Infento manual.
3. Never exceed the maximum weight. You can find the maximum weight for every specific ride in our manual.
4. Always check the manual to see the minimum and maximum age as well as the minimum and maximum length for every specific ride.
5. Always wear safety equipment such as a helmet, knee pads and elbow pads. We recommend riders always wear a properly fitted helmet that complies with local or national guidelines or laws. Keep chinstrap of helmet securely buckled.
6. Always wear closed toed shoes (lace-up shoes with rubber soles), never ride barefooted or in sandals, and keep shoe laces tied and out of the way of the wheels.
7. Avoid streets and surfaces with water, sand, gravel, dirt, leaves, and other debris. Wet weather impairs traction, braking and visibility.
8. Excessive exposure to sunlight, temperatures below 0 degrees Celsius, water, sand, gravel, dirt, leaves, and other debris can damage, shrink, expand or weaken parts. Keep your ride in a dry environment with proper heating.
9. Avoid sharp bumps, drainage grates and sudden surface changes. Your Infento ride may suddenly stop.
10. Ride on smooth, paved surfaces away from

motor vehicles. Wet, slick or uneven and rough surfaces may impair traction and contribute to possible accidents.

11. Never risk damaging surfaces, such as carpet or flooring, by use of an Infento ride indoors.
 12. Never use near motor vehicles, streets, roadways, alleys, swimming pool areas, hills, steps, sloped driveways, inclines and public highways.
 13. Watch out for pedestrians, skaters, skateboards, scooters, bikes, children or animals who may enter your path, and respect the rights and property of others.
 14. Avoid excessive speed associated with downhill rides.
 15. Do not use at night or in periods with reduced visibility.
 16. Before every use, please make sure that the complete ride and all joints have been assembled tightly, as with use, joints may wear out.
 17. Before using your Infento ride, please check that the screws are tightened securely.
 18. It's your own responsibility if you modify the product other than manufacturer's instructions.
 19. Maintain a hold on the handlebars at all times.
 20. Brake will get hot from continuous use. Do not touch after braking.
 21. Periodically check hardware and tighten if necessary. Replace worn or broken parts immediately.
 22. Skill is required to avoid falls or collision causing injury to the user and third parties.
 23. Check operation of breaks every time before bicycle is ridden.
 24. Check local laws before you start with riding.
 25. Never tow wagons, other vehicles, or children on skates or skateboards.
 26. Make certain that anyone who uses an Infento ride has been fully instructed in its operation.
 27. Instruct your child on how to use the breaks.
 28. Do not perform stunts.
 29. Never use headphones or a cell phone when riding.
 30. Only one rider at a time on an Infento ride.
 31. Do not allow children to stand on the product at any time.
- FAILURE TO USE COMMON SENSE AND HEED THE ABOVE WARNINGS INCREASES RISK OF SERIOUS INJURY. USE WITH APPROPRIATE CAUTION AND SERIOUS ATTENTION TO SAFE OPERATION.**

SAFETY SECTION



OUR KITS CONTAIN SMALL PARTS

This package contains small parts which, before assembly, present a choking hazard to children under the age of three. Care should be taken during unpacking and assembly to insure that all small parts and plastic bags are accounted for and kept out of the reach of children.

QUESTIONS OR SUPPORT NEEDED?

You can mail us all your questions at:
support@infentorides.com
and our team will reply you as soon as possible.



MAINTENANCE | INSTRUCTION



1. Oil or grease moving parts periodically.
2. Check nuts and bolts often and tighten if necessary.
3. Any parts showing evidence or wear should be replaced immediately.
4. Follow closely the assembly instructions pertaining to the proper adjustments of parts
5. Periodically check the brake system for proper function
6. Periodically check the steering mechanism for proper function
7. Check the air pressure in the tires to be the amount specified in the manual
8. Periodically check the bicycle's tooth belt to be sure that it is not too loose which could allow the chain to slip off the sprockets.

RECOMMENDED TOOLS



4 x Allen key
3, 4, 5, 6 mm



1 x Tapeline

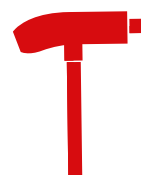

1 x T-handle
for Allen key

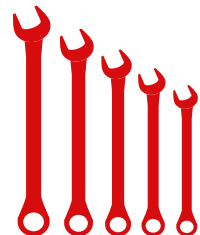





5 x Wrench
10, 13, 14, 15, 19 mm



1

ride **BULLDOG**

First, get all required materials stated here and then follow the instructions.

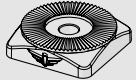
- 
T-Positioning block
2x
- 
Positioning block
2x
- 
Bolt M8x40
1x
- 
Multi angle joint
1x
- 
Swivel plate 40x40
2x

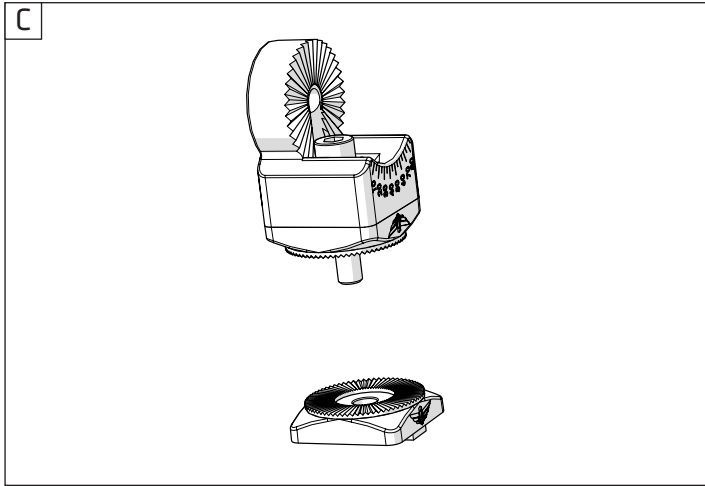
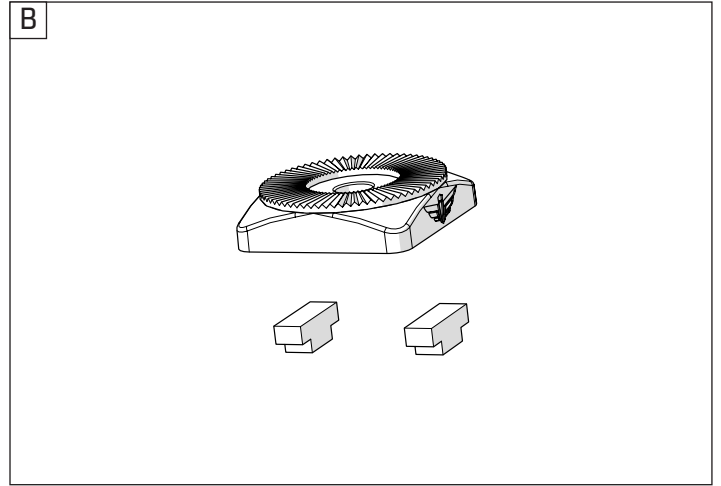
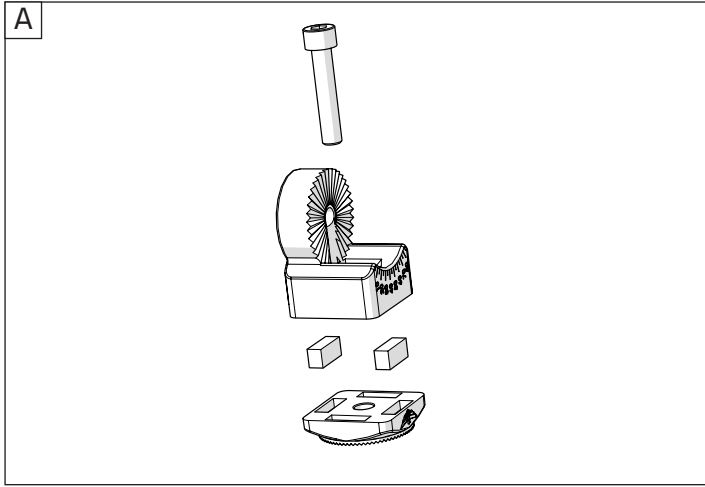

The positioning blocks are some of the smallest Infento parts but they are also some of the most important. They ensure that everything connects to each other properly. This prevents parts from twisting and coming loose when under pressure. Therefore, always use at least two positioning blocks

Double check here:

Does your result looks **exactly** like the image at the bottom of the page?

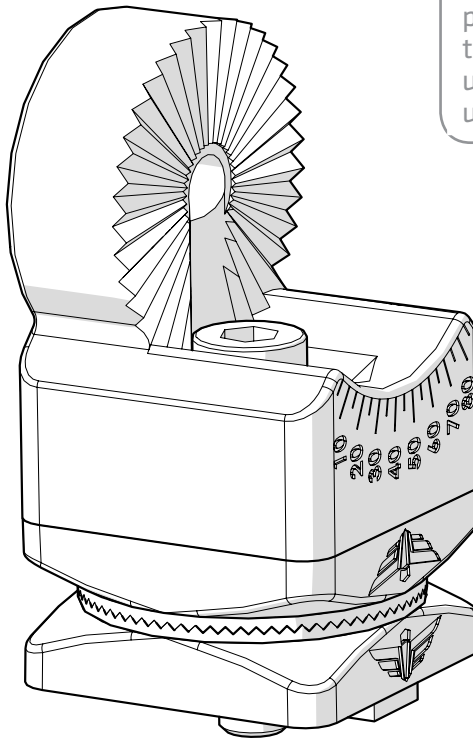

TOP 3 REQUIREMENTS MAKING A GREAT INFENTO EXPERIENCE:



1

Tighten bolts with full force (15Nm) to prevent them from coming loose.

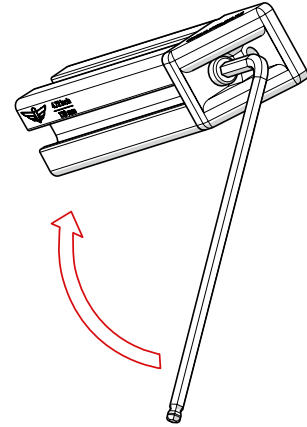

2

Constructing and playing always under supervision of an adult.



3

Check frequently if all parts are still firmly tightened and function properly.





2

ride **BULLDOG**

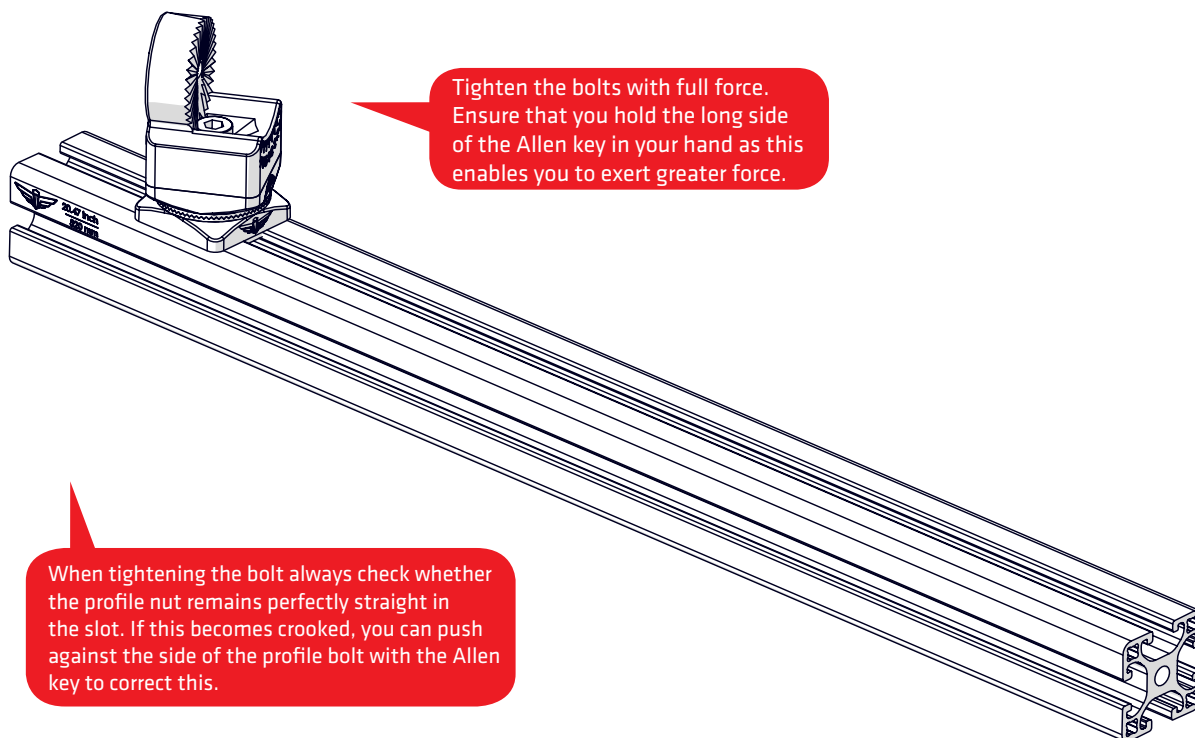
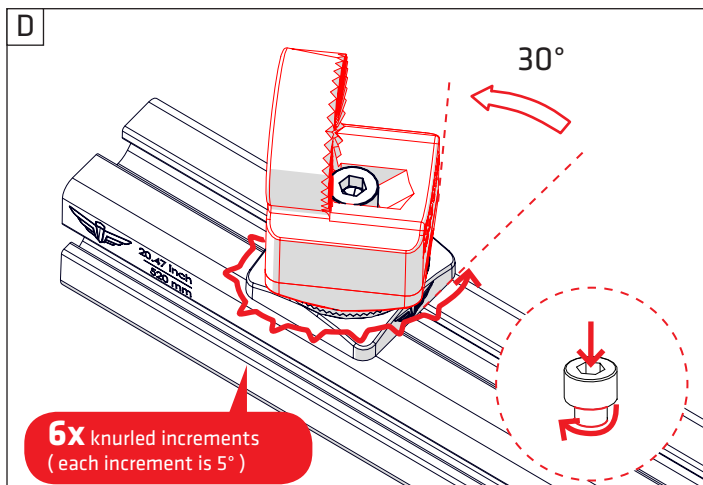
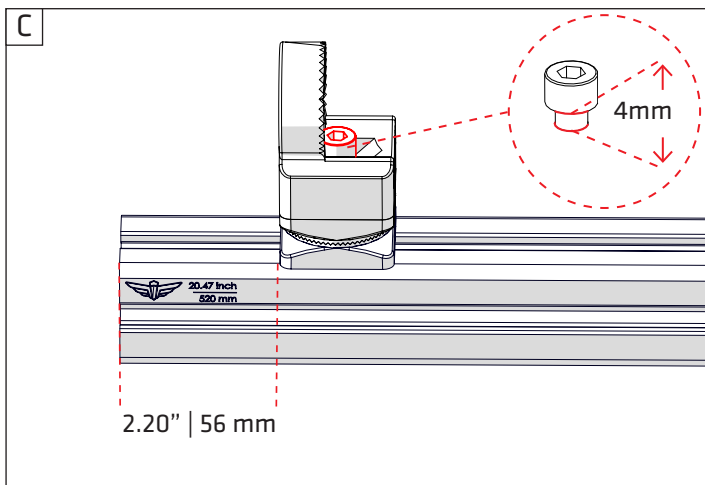
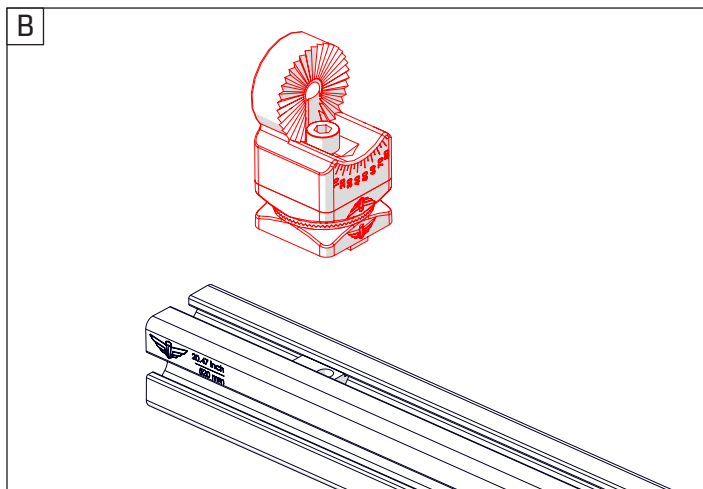
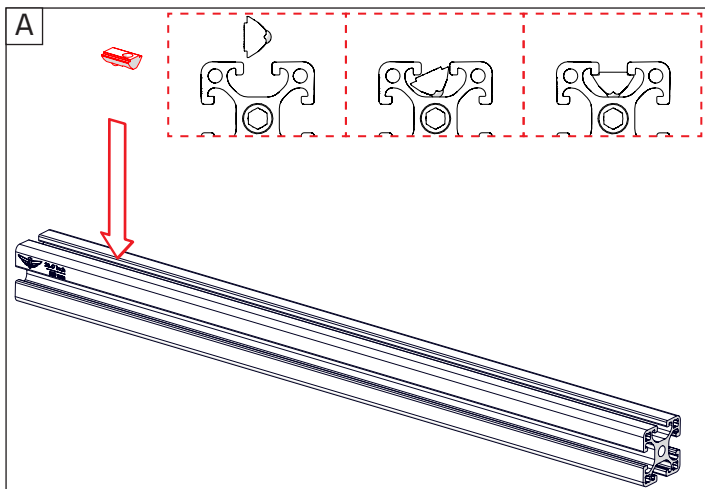
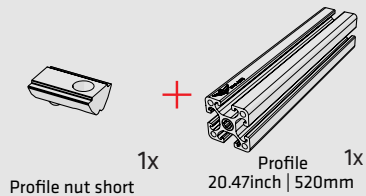

Tighten the bolts with full force. Ensure that you hold the long side of the Allen key in your hand as this enables you to exert greater force.

When tightening the bolt always check whether the profile nut remains perfectly straight in the slot. If this becomes crooked, you can push against the side of the profile bolt with the Allen key to correct this.



3

ride **BULLDOG**

- 2x T-Positioning block + 2x Positioning block + 1x Bolt M8x40 + 1x Multi angle joint + 2x Swivel plate 40x40

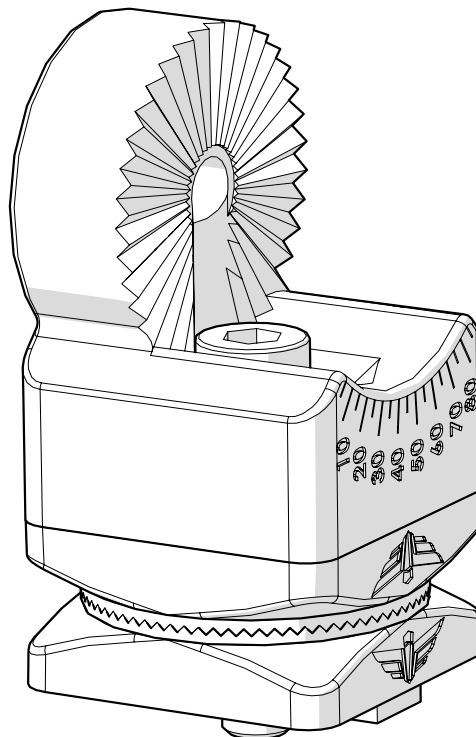
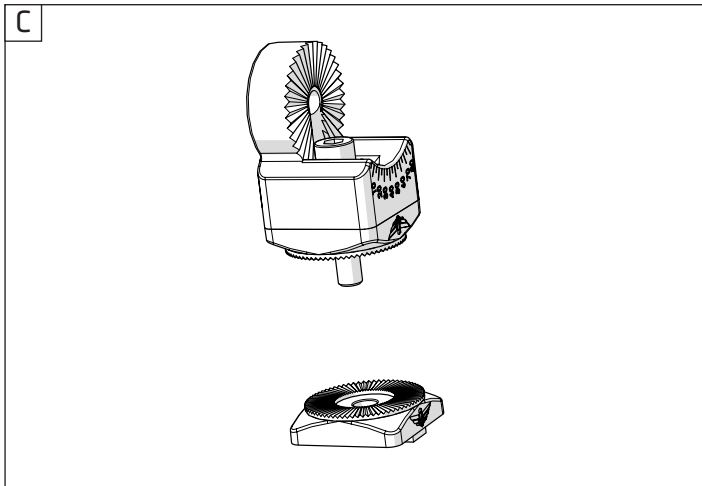
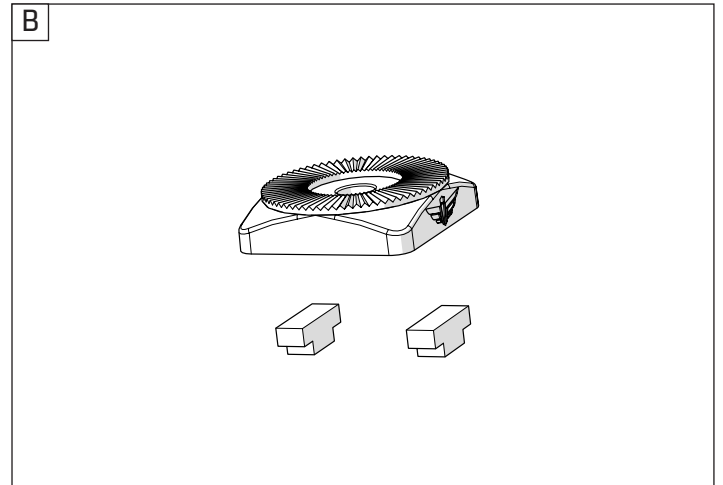
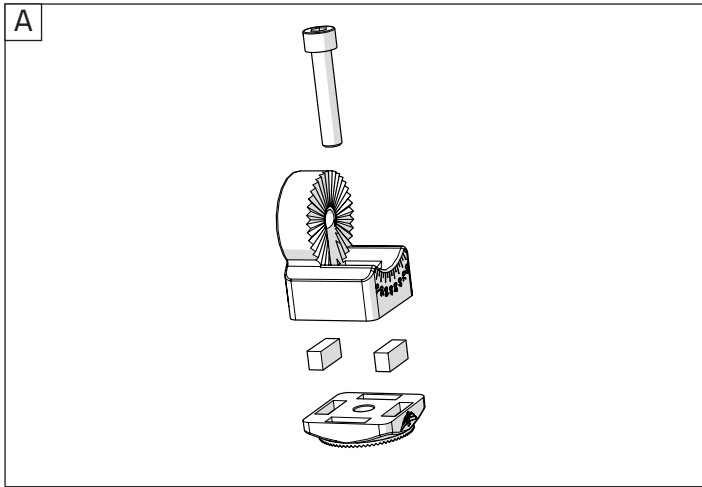



4

ride **BULLDOG**



1x
Profile nut short

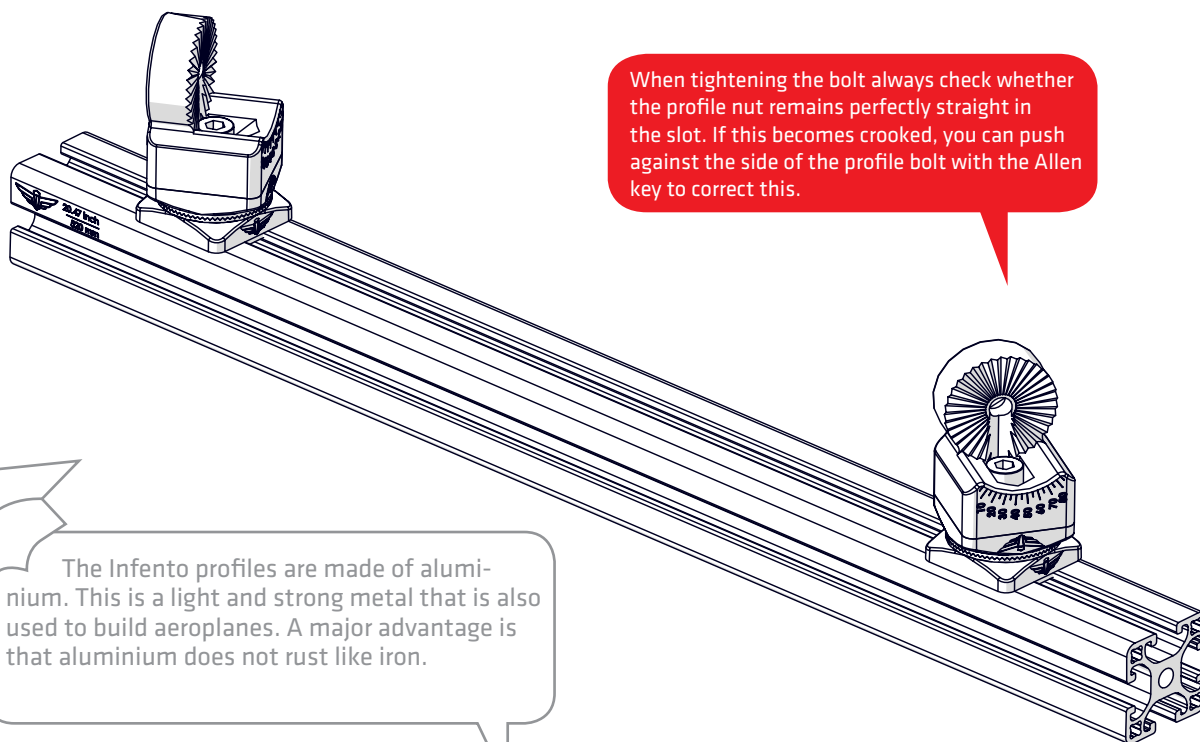
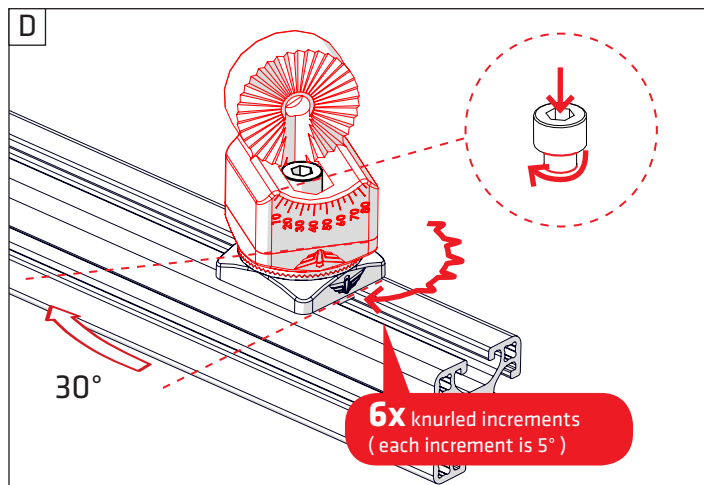
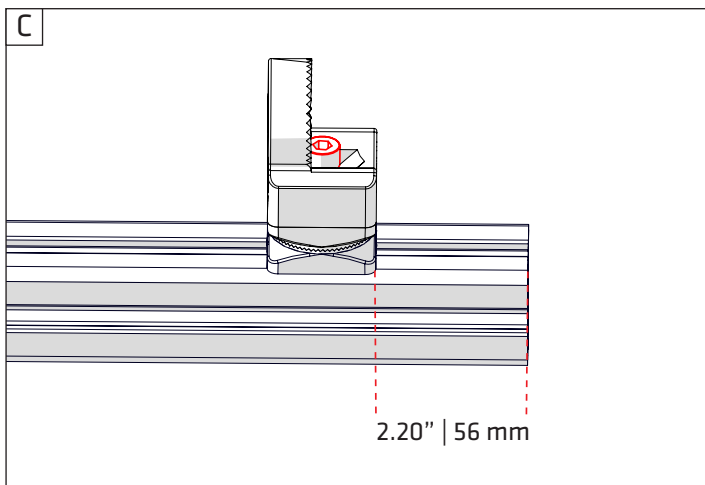
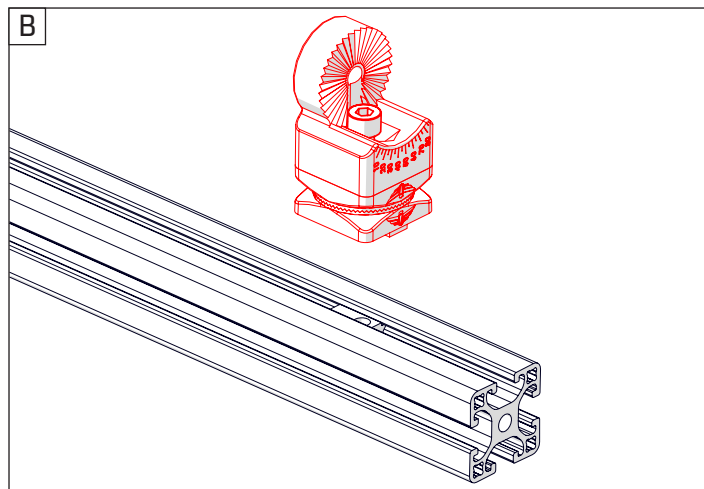
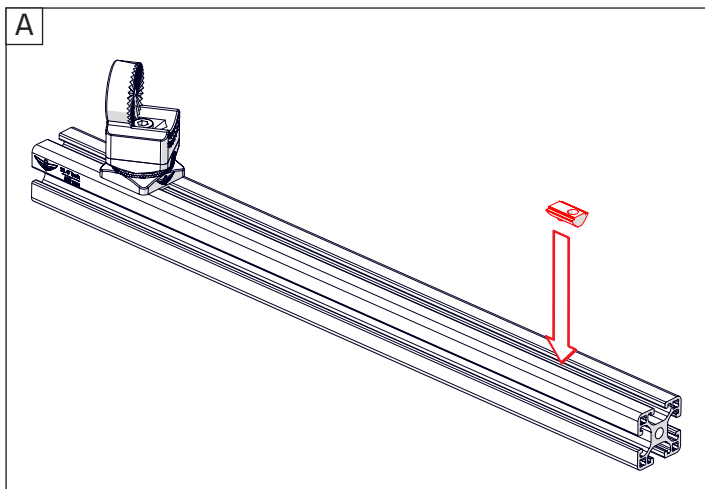





When tightening the bolt always check whether the profile nut remains perfectly straight in the slot. If this becomes crooked, you can push against the side of the profile bolt with the Allen key to correct this.

The Infento profiles are made of aluminium. This is a light and strong metal that is also used to build aeroplanes. A major advantage is that aluminium does not rust like iron.



5

ride **BULLDOG**

- 
Bolt M8x20
- + 
T-Positioning block
- + 
Profile nut short
- + 
Multi angle joint

2x

4x

2x

2x

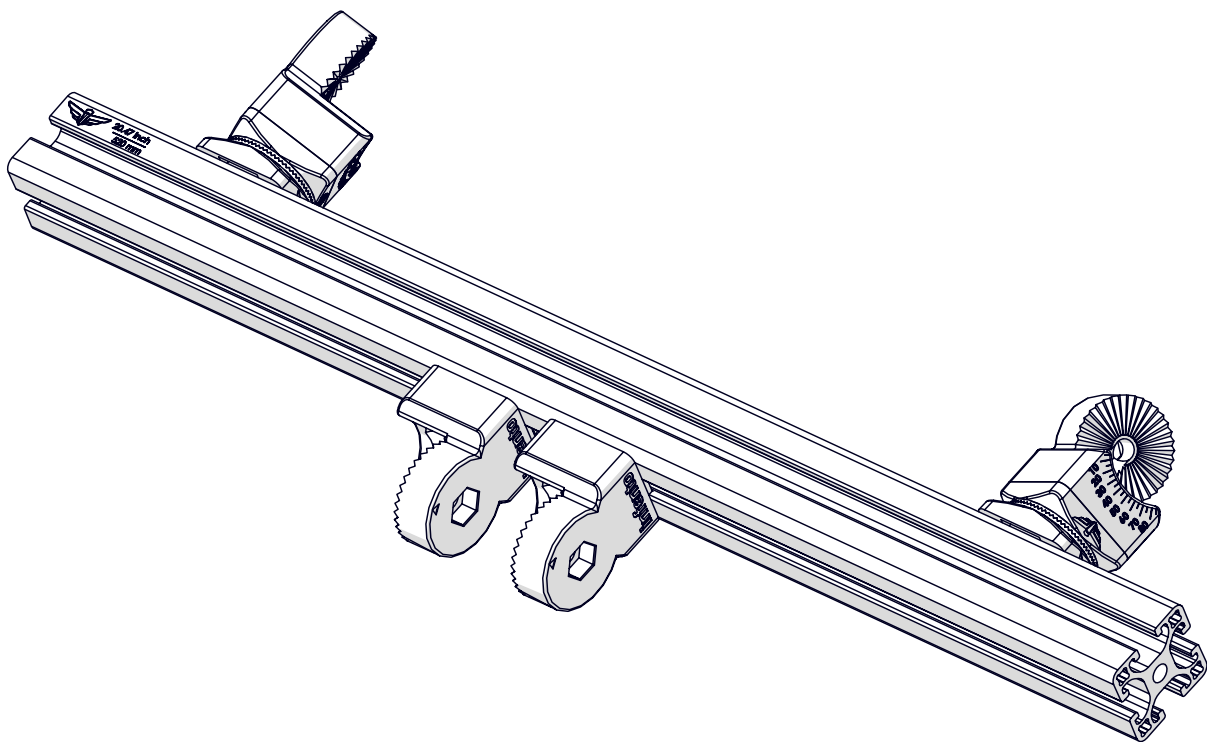
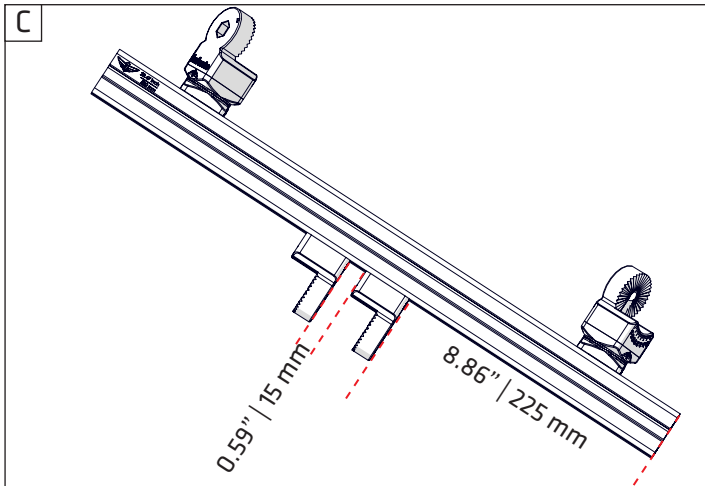
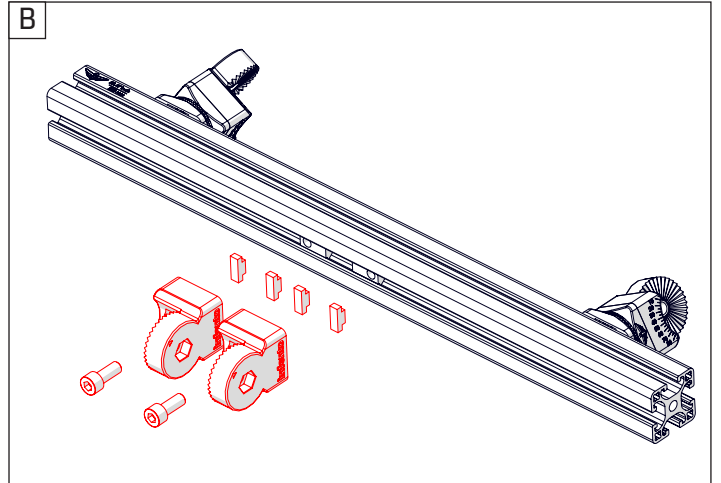
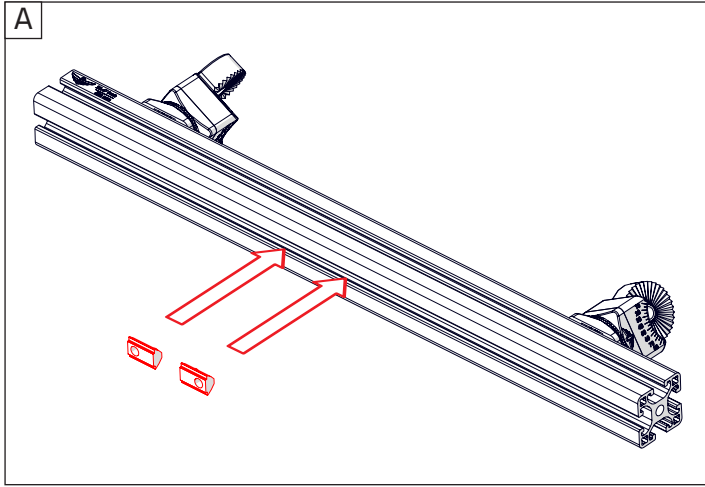



6

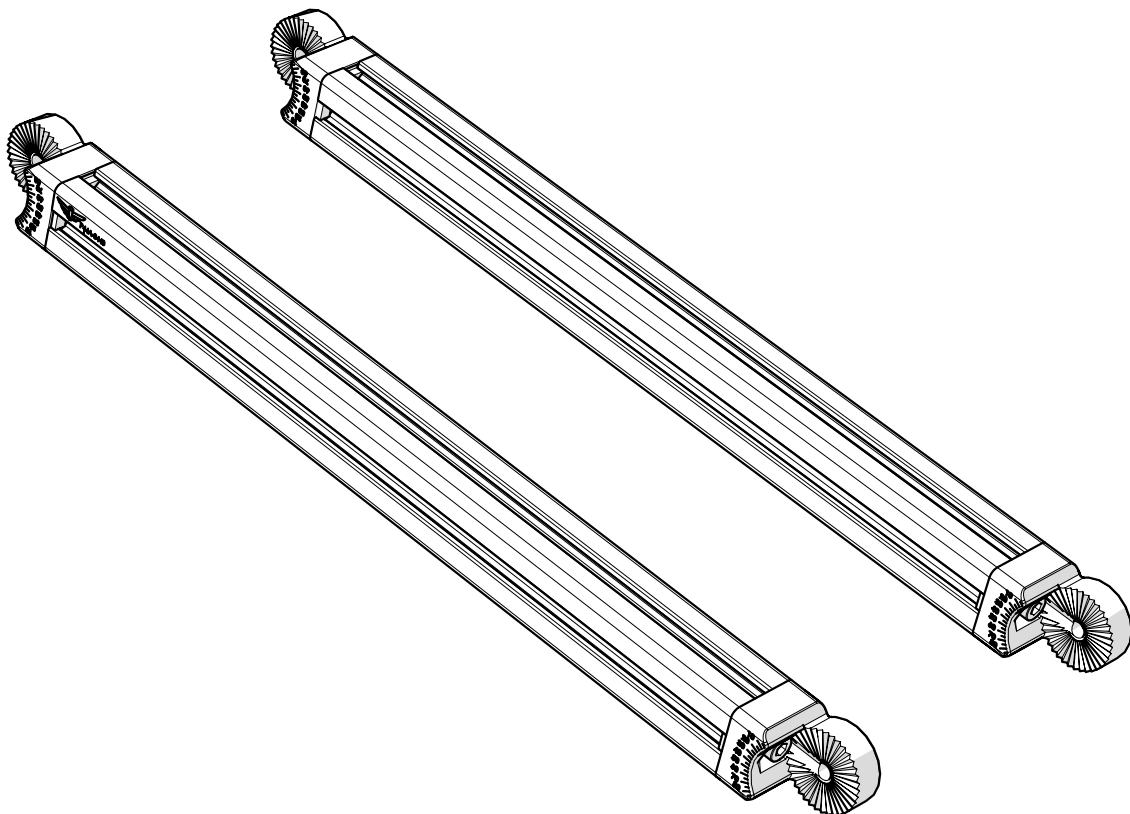
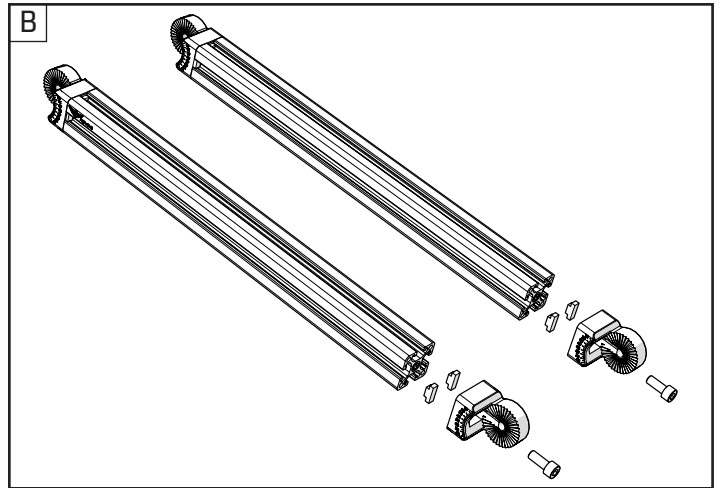
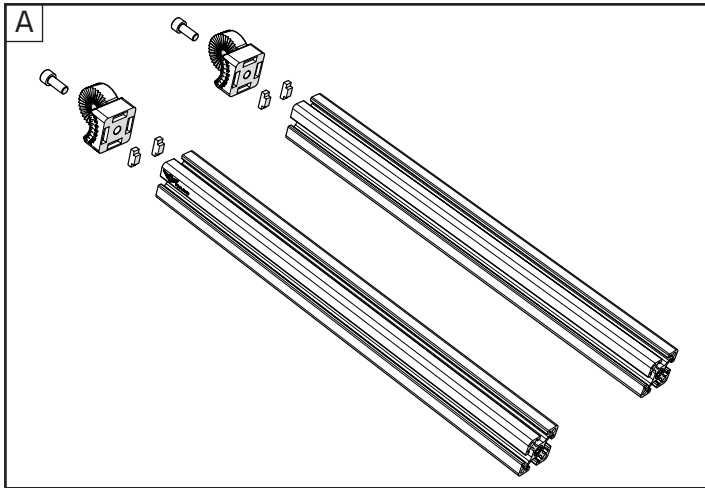
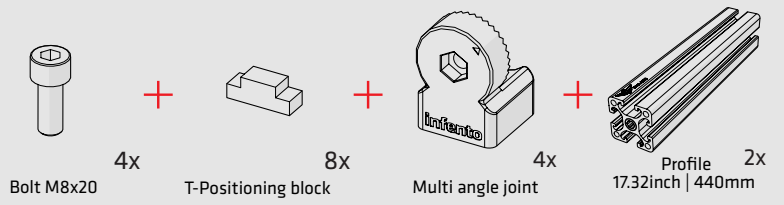

ride **BULLDOG**





7

ride **BULLDOG**

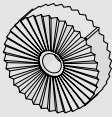
- 
Locknut M8
 - +
 - 
Bolt M8x35
 - +
 - 
Knurled disc 1 stripe
- 2x 2x 2x

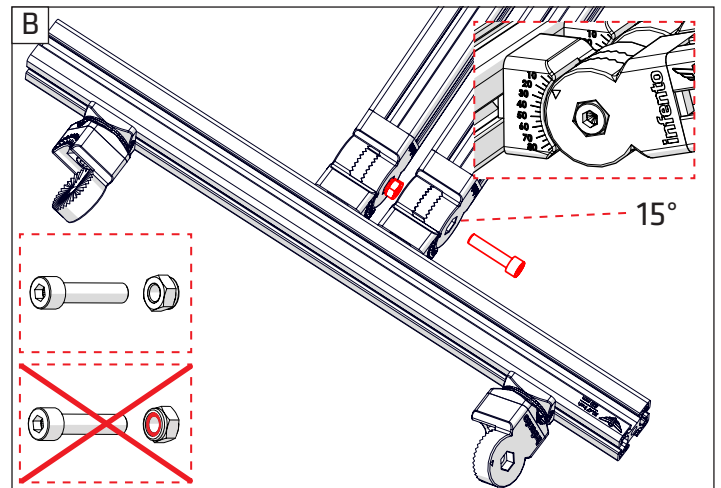
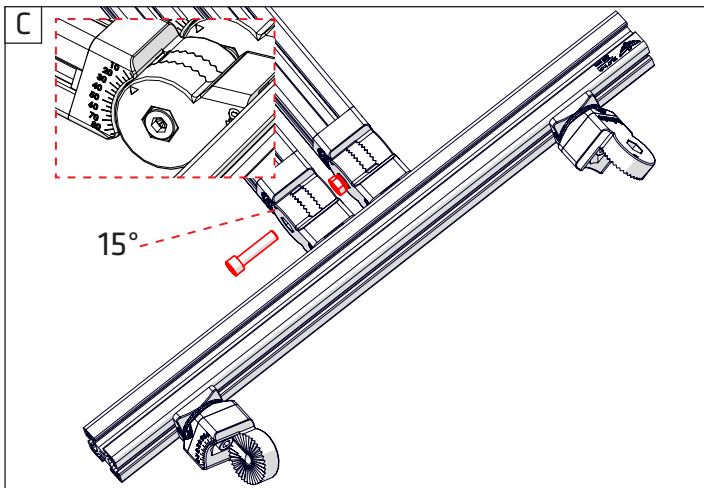
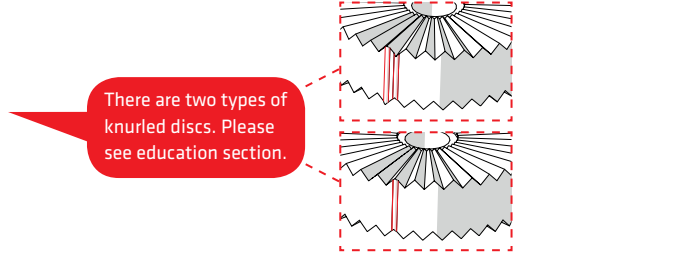
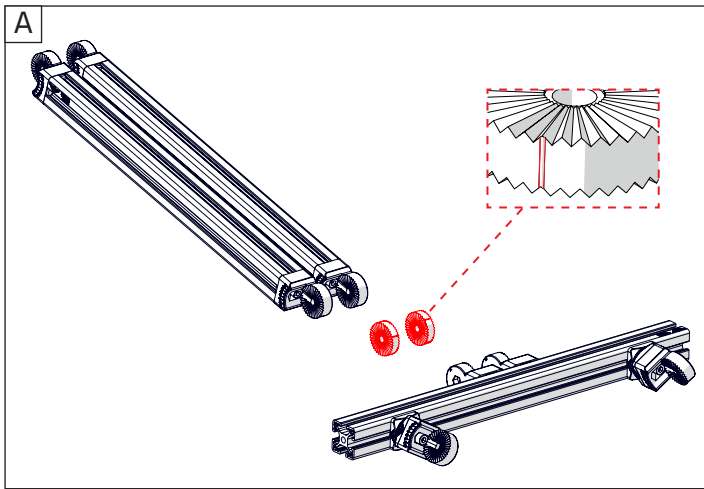

There are two different knurled discs. One for each corner ending in a 5 (5-15-25-etc. degrees), which has one stripe round the outside, and one for each corner that ends in a 0 (0-10-20-etc degrees), which has two stripes round the outside.

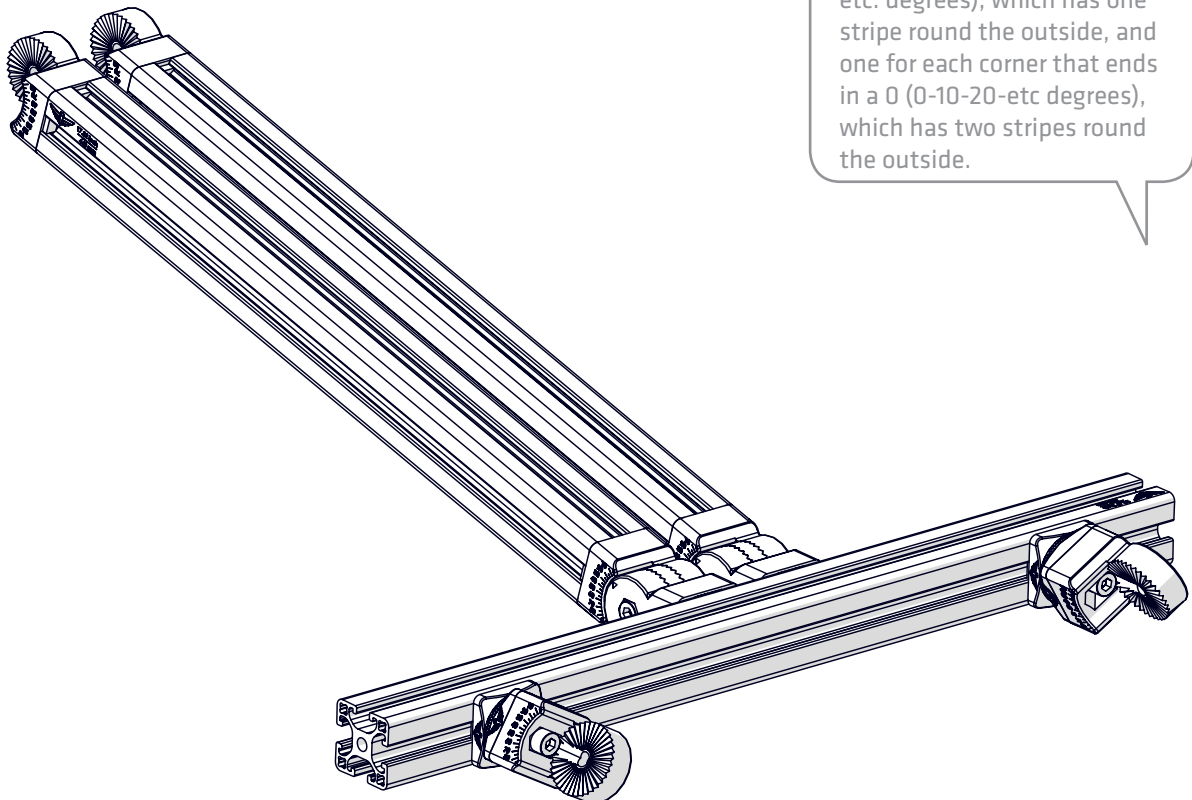



8

ride **BULLDOG**



+



+



T-Positioning block 4x

Bolt M8x20 2x

Bearing block 40x40_8 2x

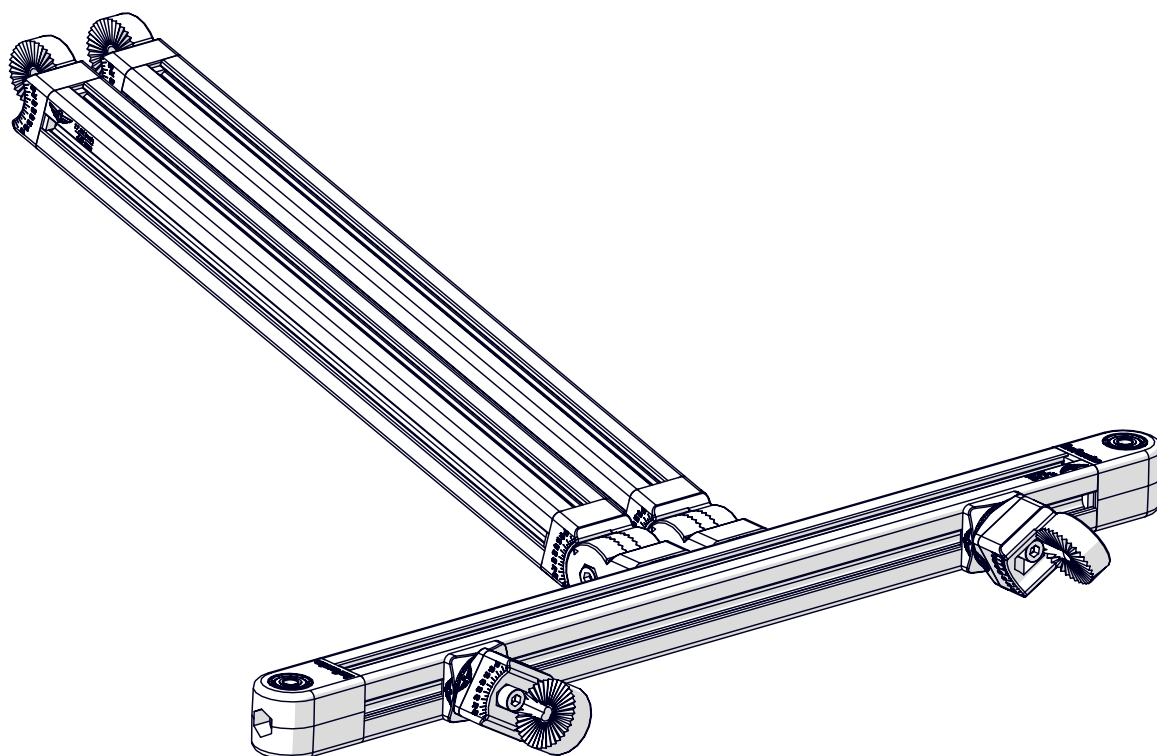
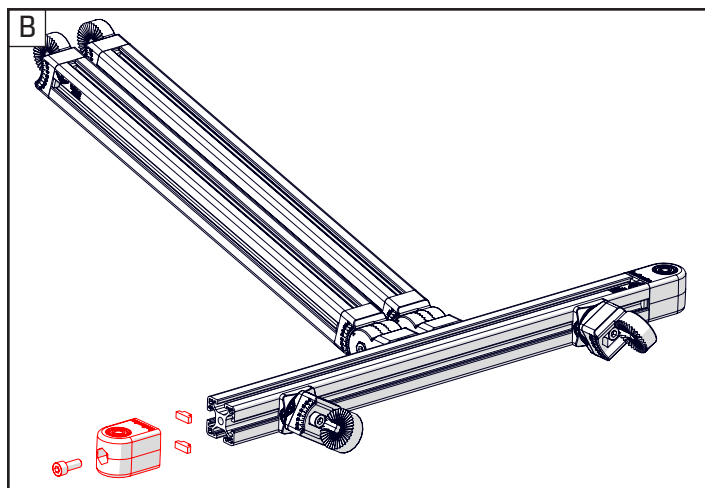
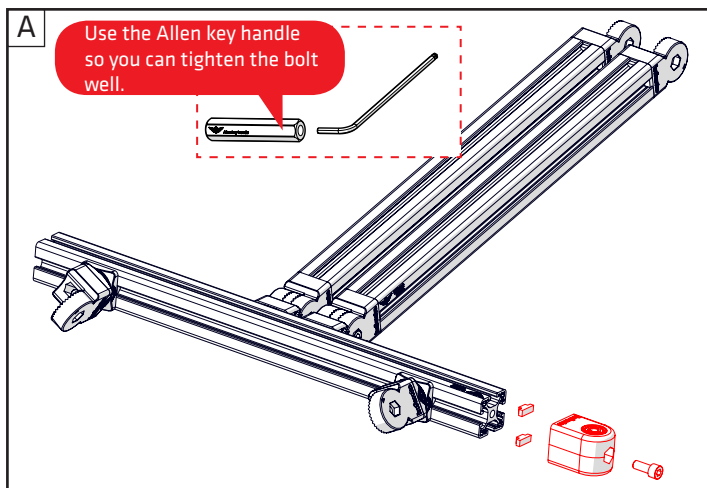



9

ride **BULLDOG**



Locknut M8

1x



Washer M8-16

2x



Bolt M8x60

1x

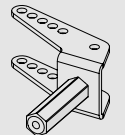

Steering arm
2.76inch | 70mm

1x

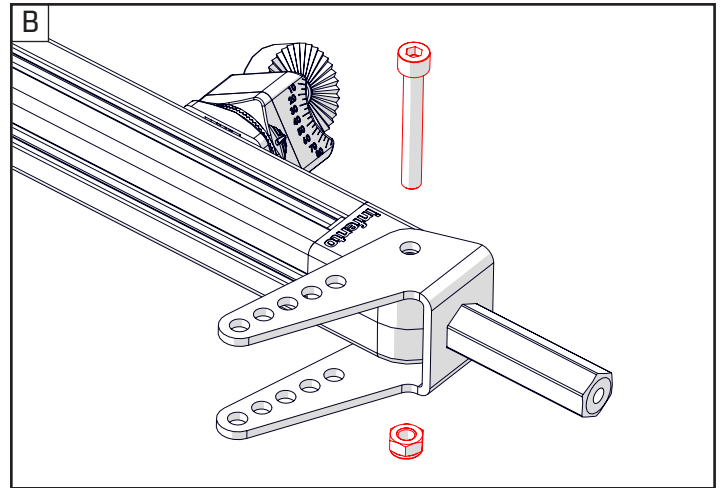
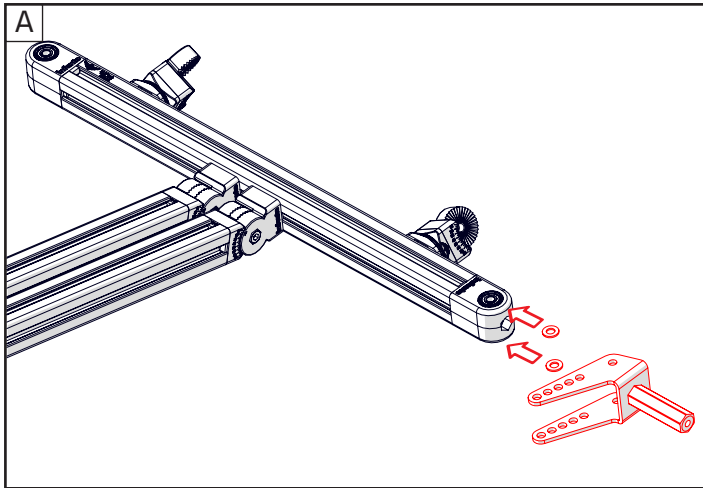

All Infento block bearings have two bearings with a spacer in between. This ensures that you can e.g. put a bolt or a washer tightly against the block bearing without it breaking. A bearing cannot withstand lateral pressure very well; this is because a bearing consists of two washers with small balls locked in between.

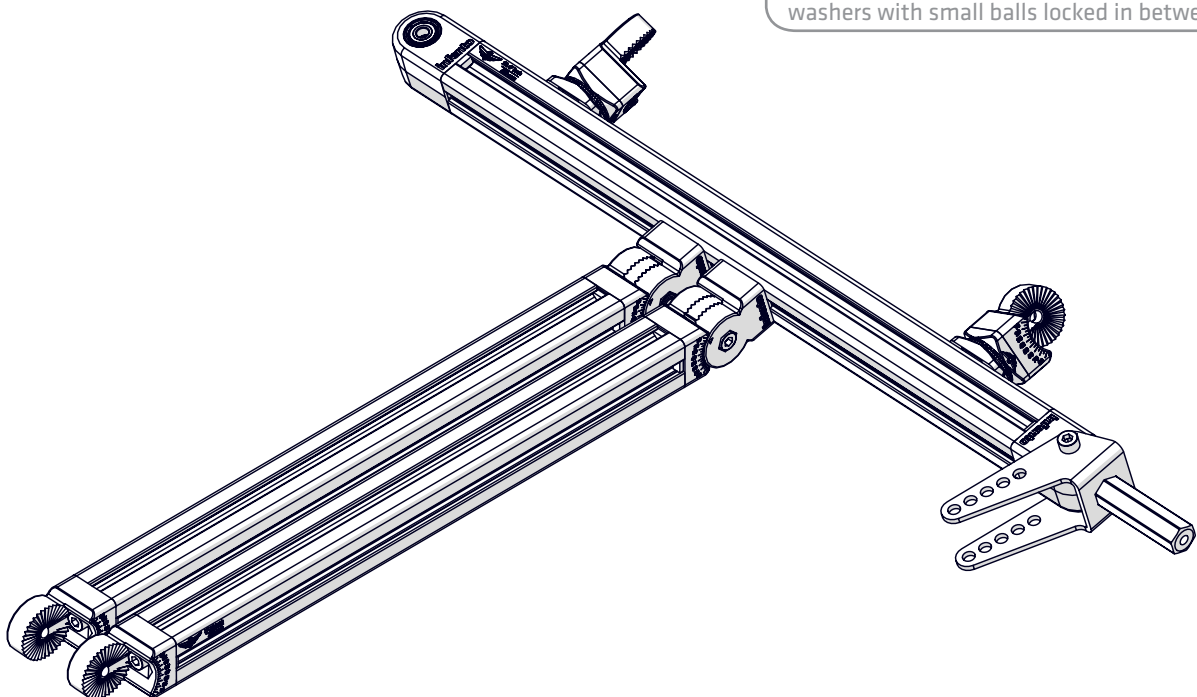



10

ride **BULLDOG**



Locknut M8

1x



Washer M8-16

2x



Bolt M8x60

1x

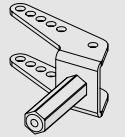

Steering arm
2.76inch | 70mm

1x

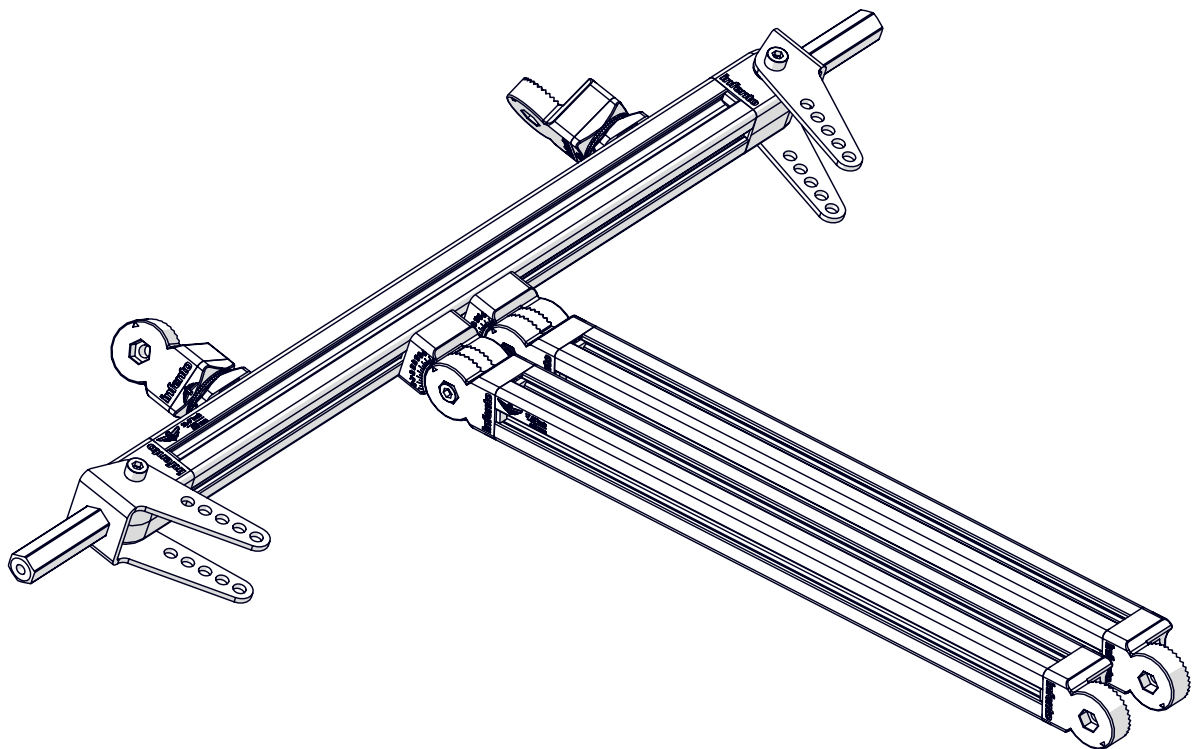
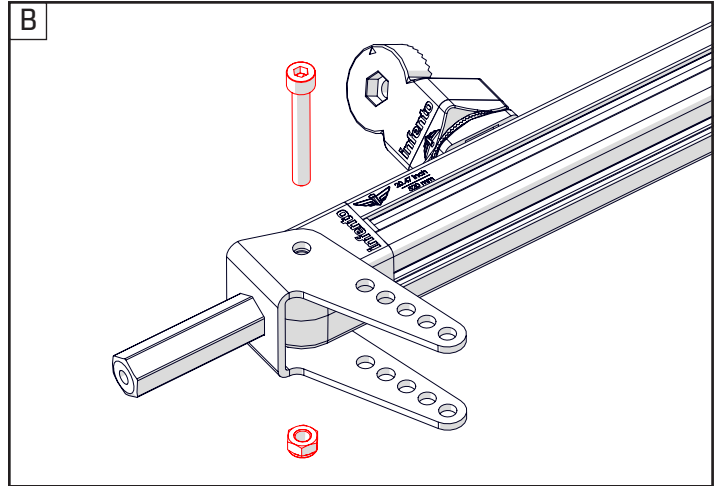
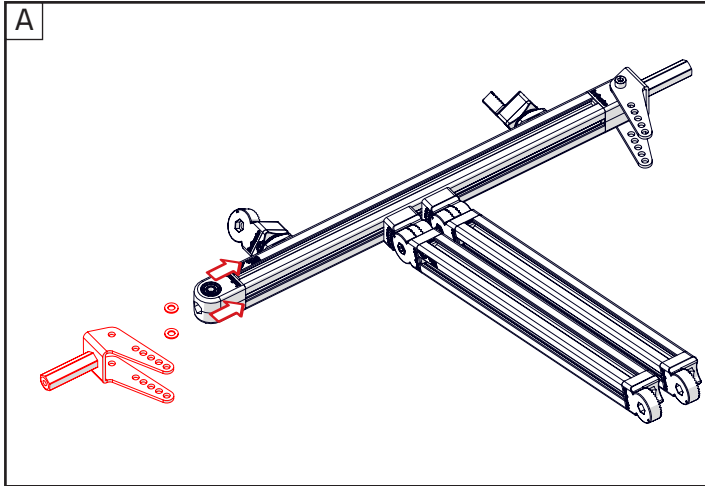



11

ride BULLDOG

- 8x T-Positioning block
- 4x Bolt M8x20
- 2x Profile nut short
- 4x Multi angle joint
- 1x Profile 5.51inch | 140mm

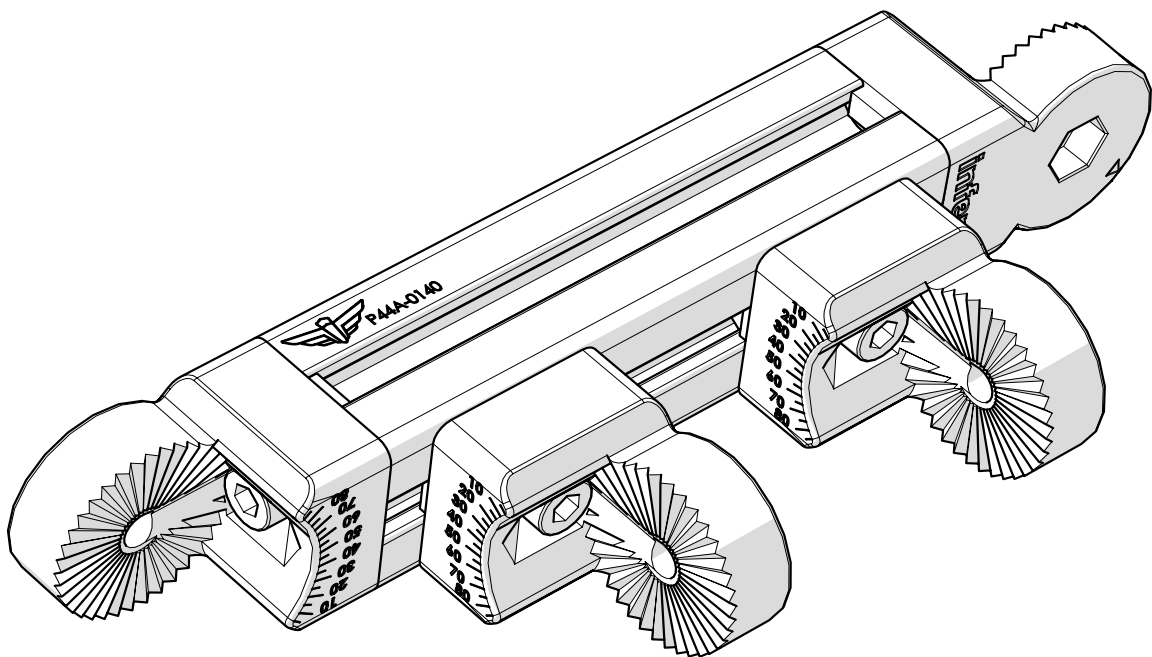
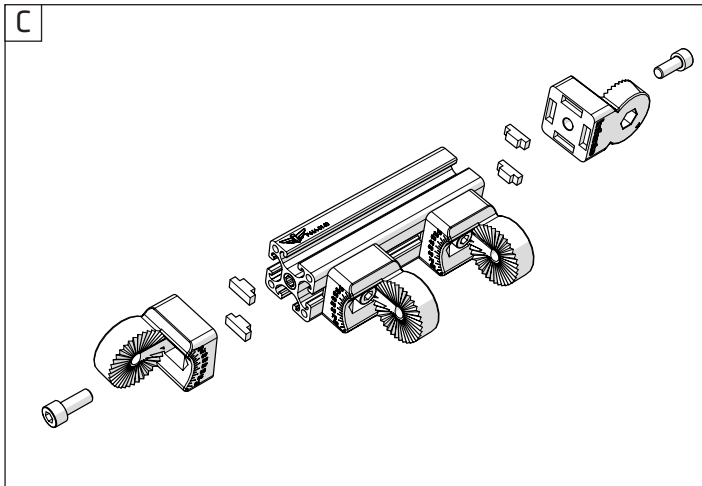
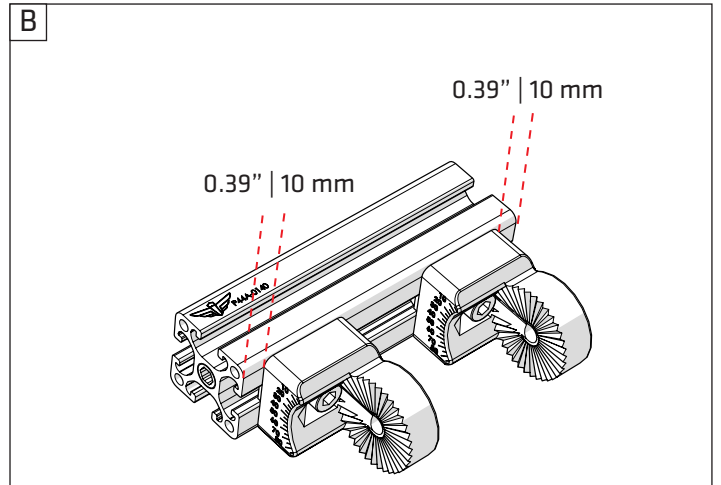
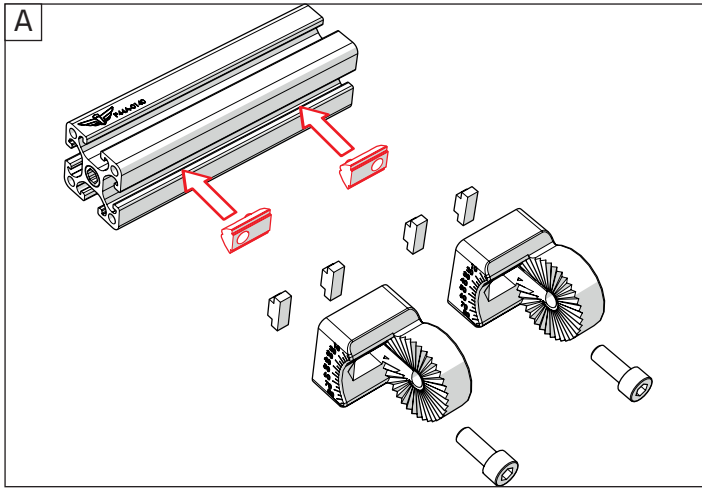



12

ride **BULLDOG**

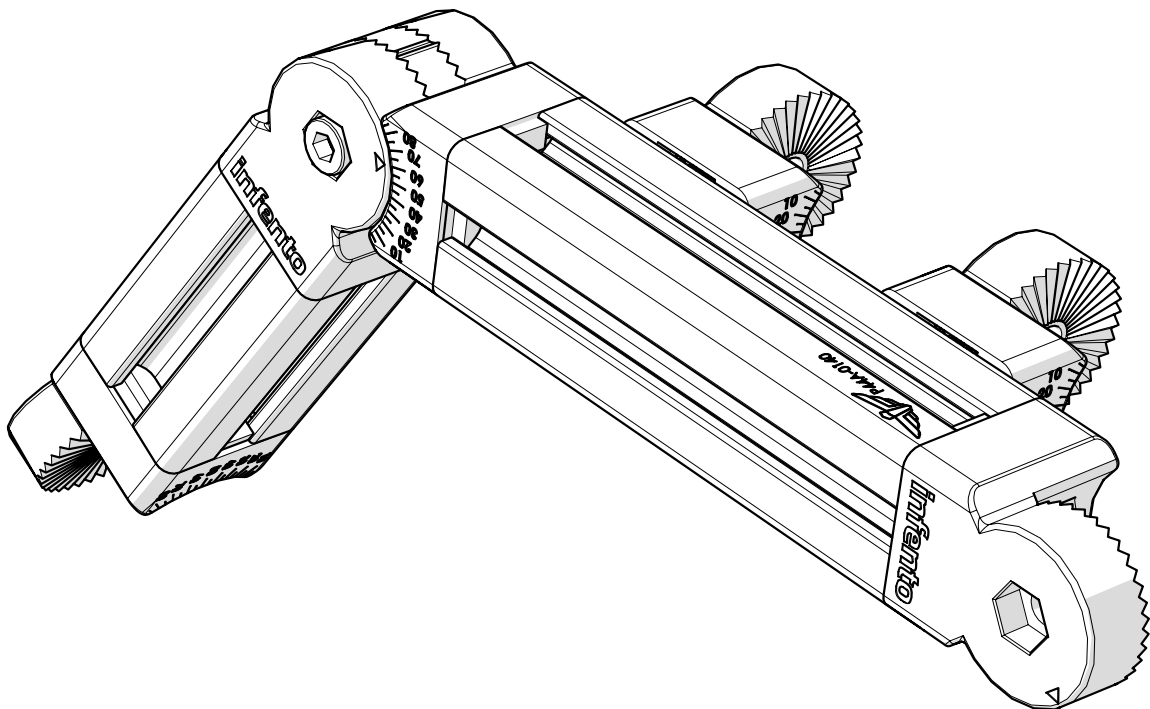
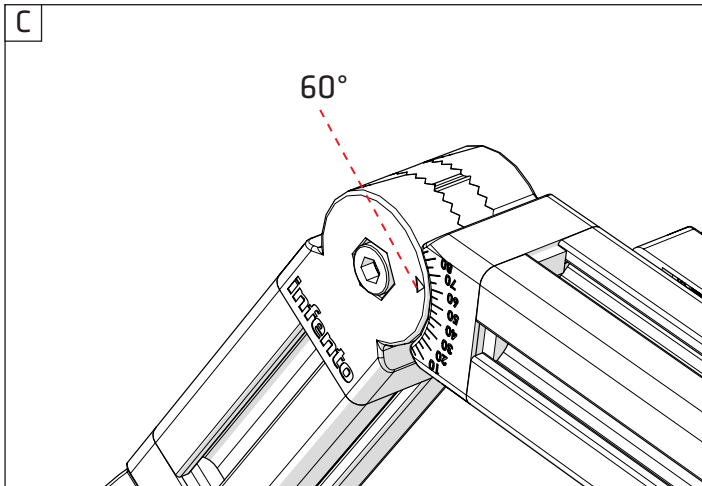
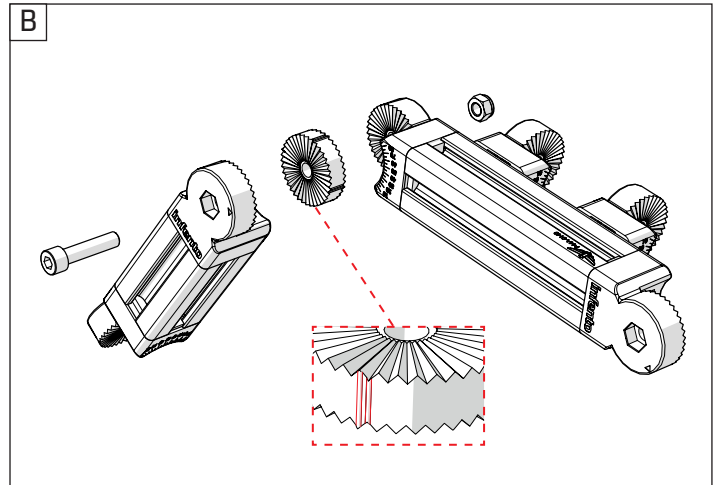
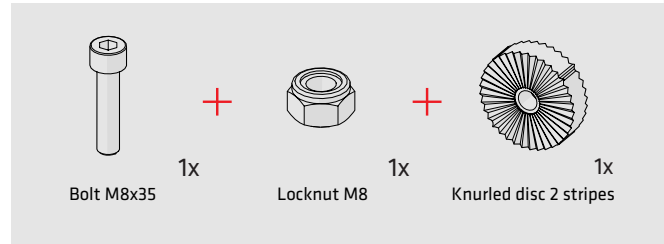
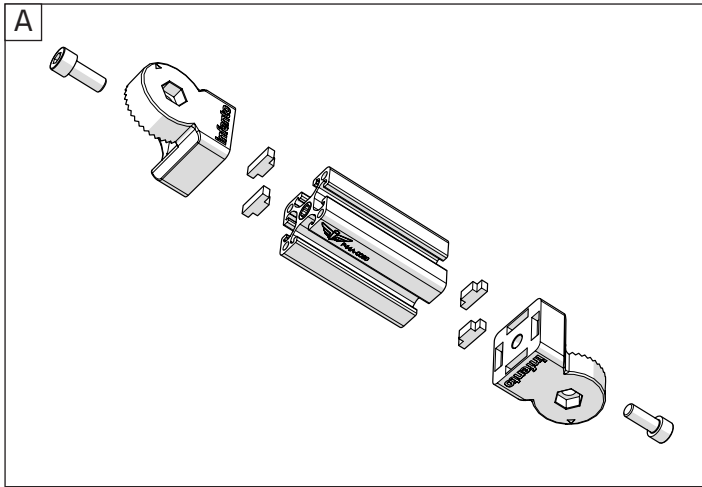
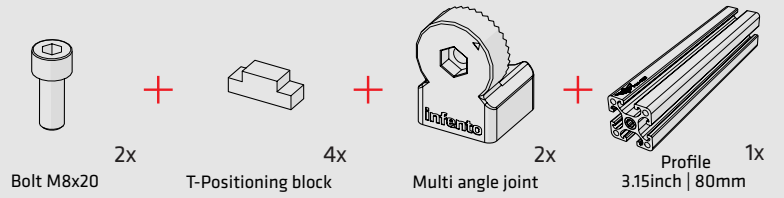



13

ride **BULLDOG**

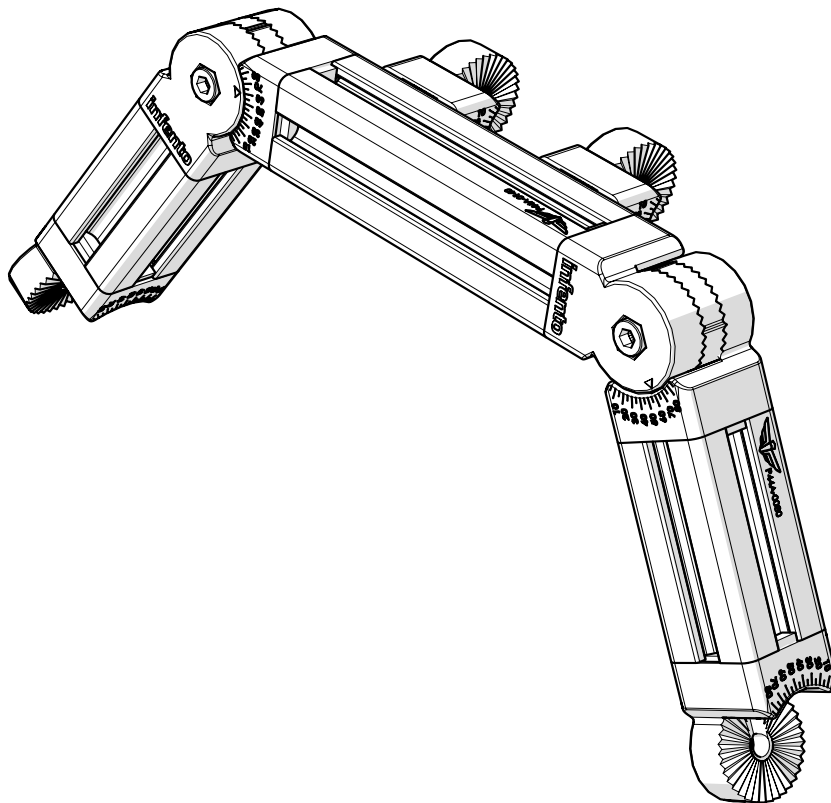
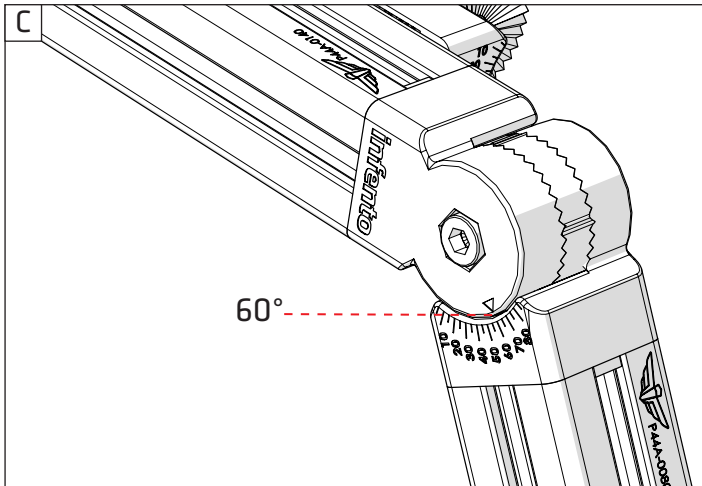
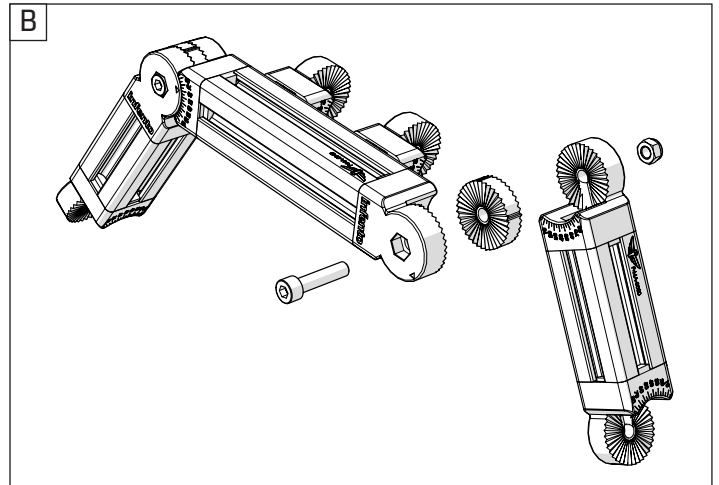
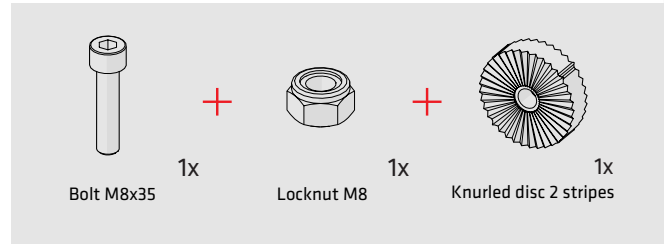
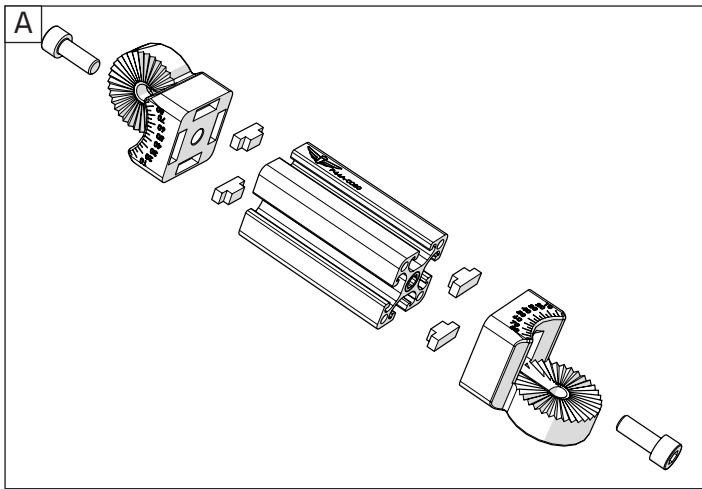
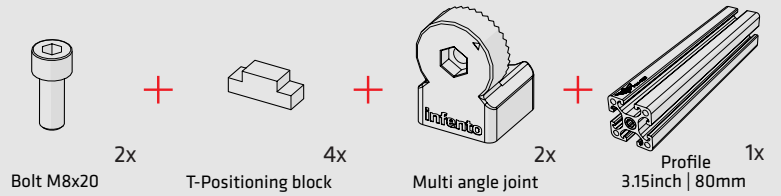



14

ride **BULLDOG**



2x

Bolt M8x35

+



2x

Locknut M8

+

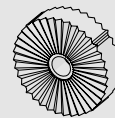

2x

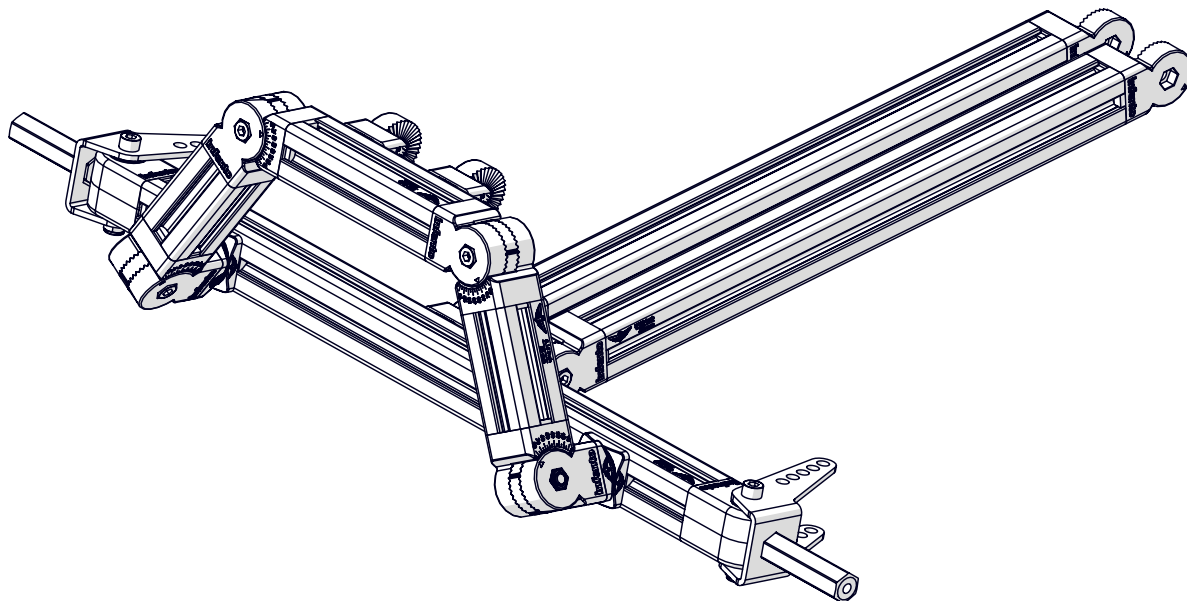
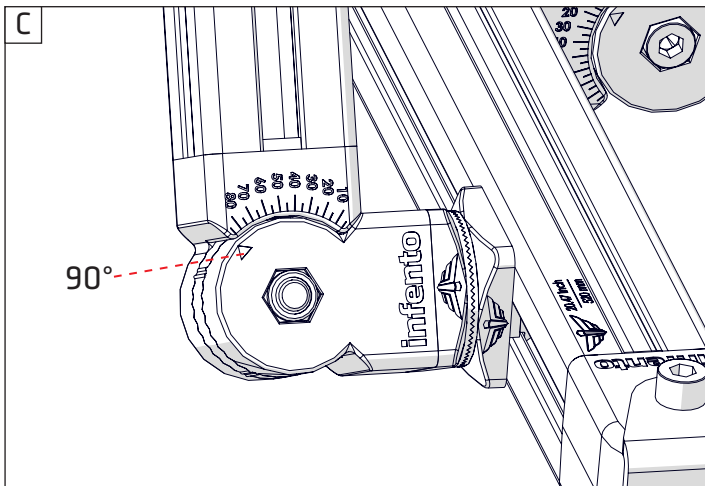
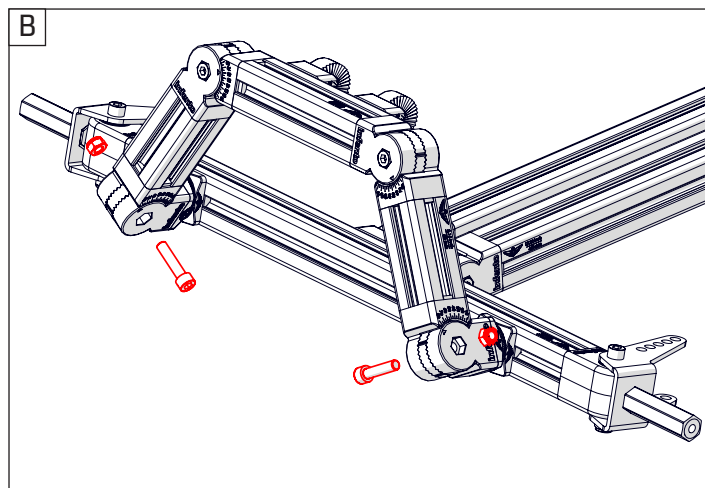
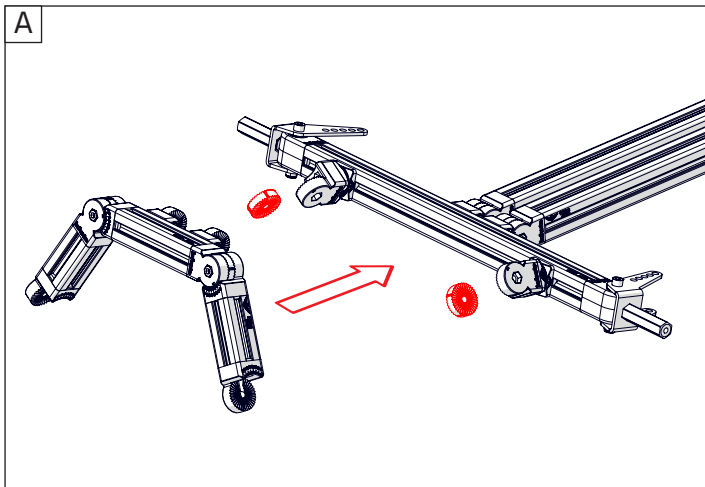

Knurled disc 2 stripes





15

ride **BULLDOG**

-  3x Bolt M8x20
-  6x T-Positioning block
-  3x Profile nut short
-  3x Multi angle joint
-  1x Profile 5.12inch | 130mm

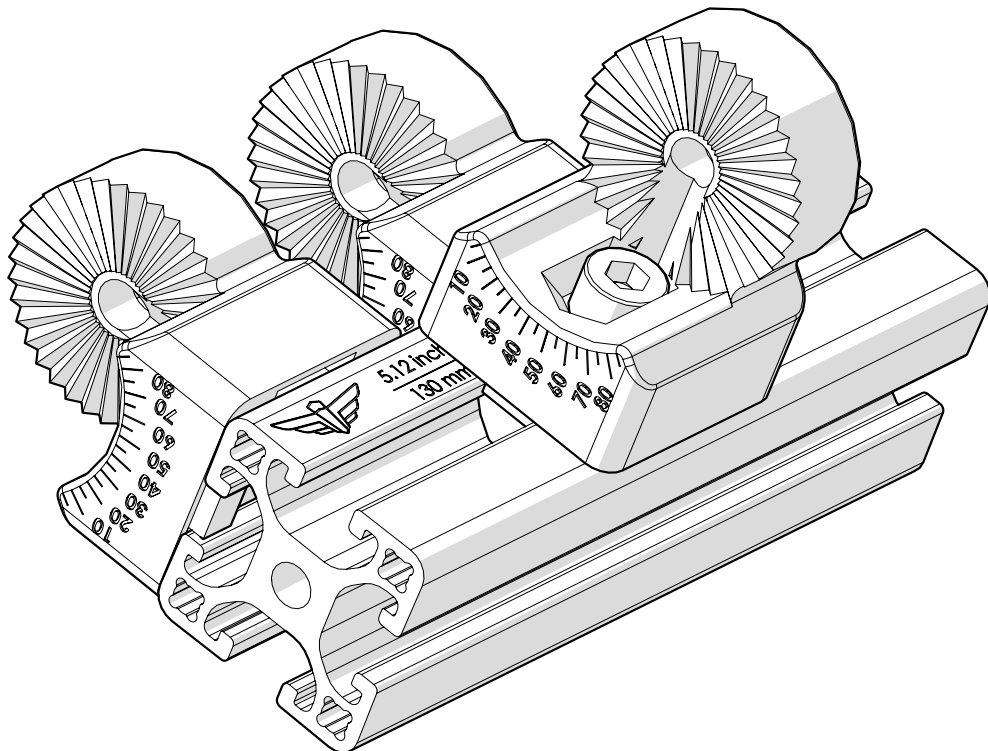
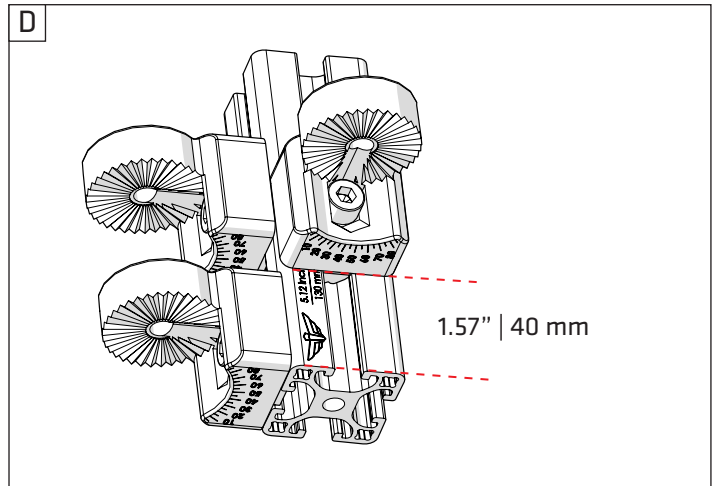
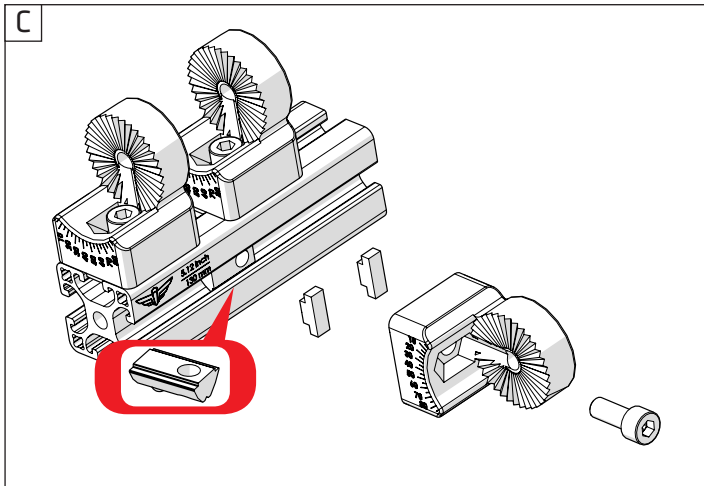
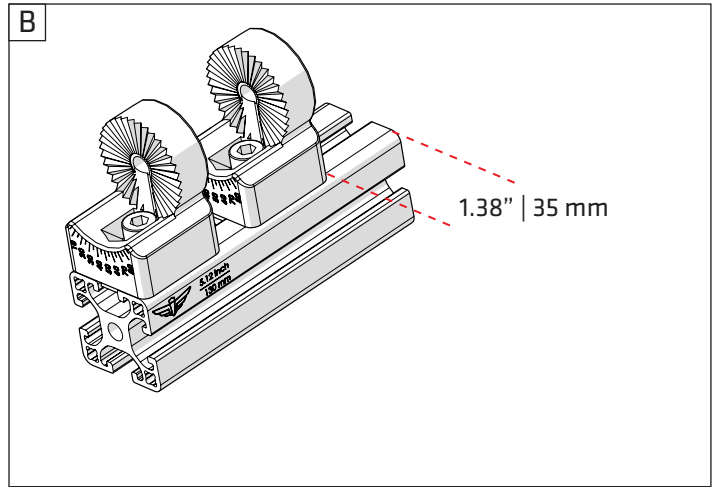
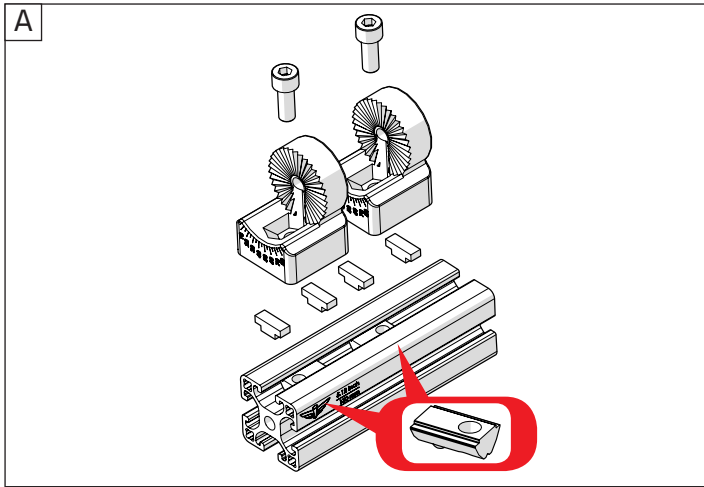



16

ride **BULLDOG**



2x

Bolt M8x35

+



2x

Locknut M8

+

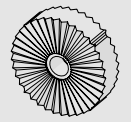

2x

Knurled disc 2 stripes

A

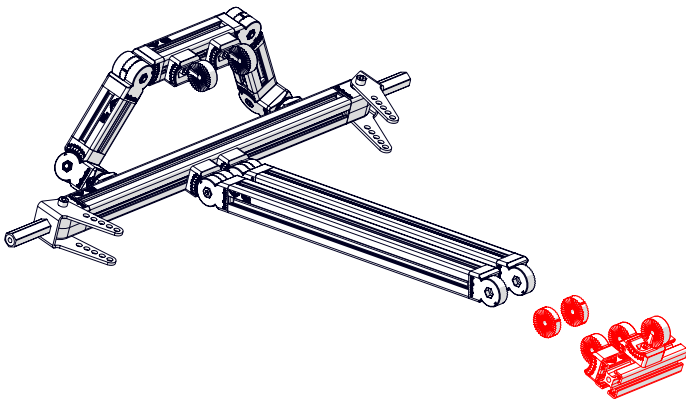

B

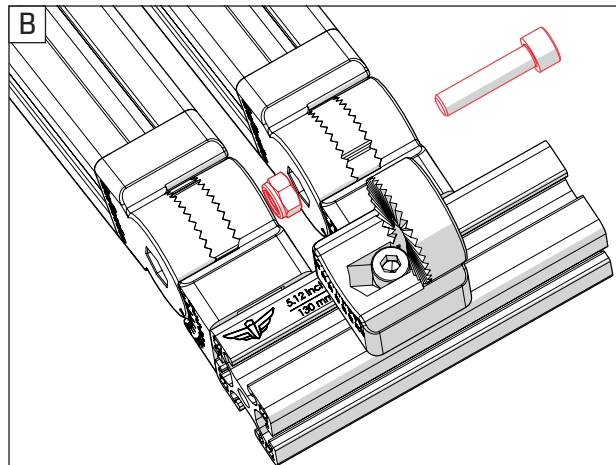

C

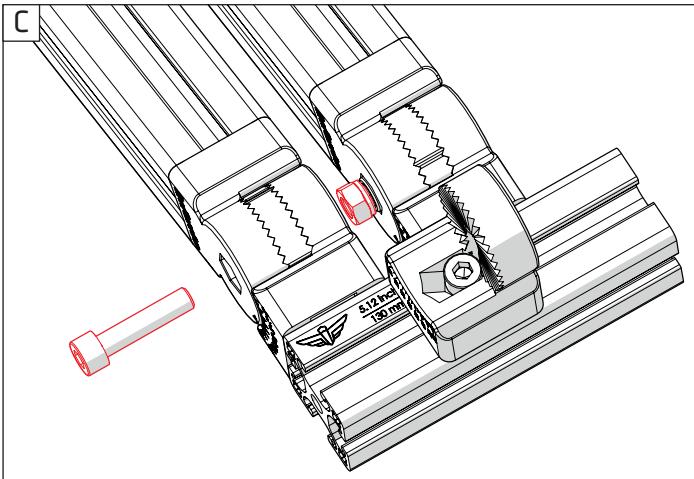

D

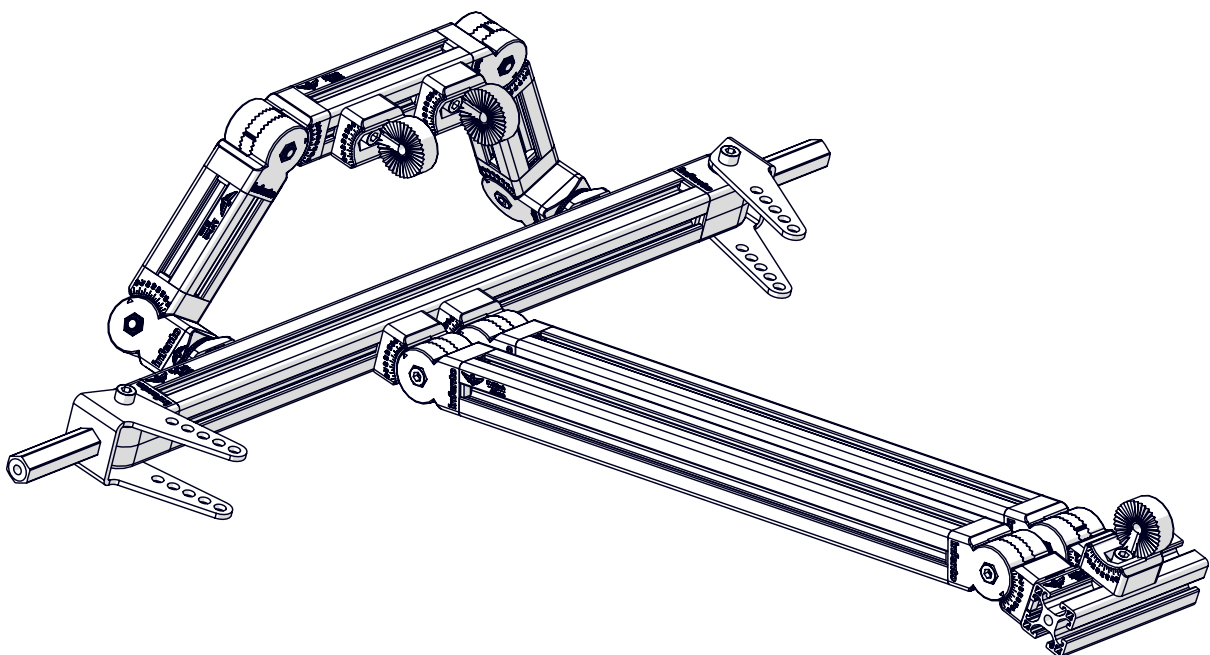
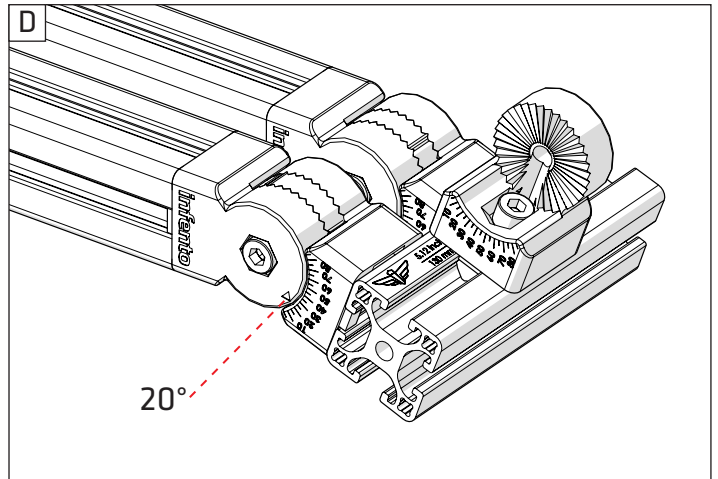



17

ride **BULLDOG**

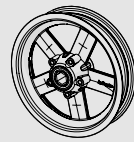

8 inch
Free spinning rim 1x

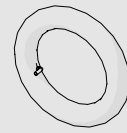

Inner tube 1x
13x2.75-8



Tire 1x
13x2.75-8

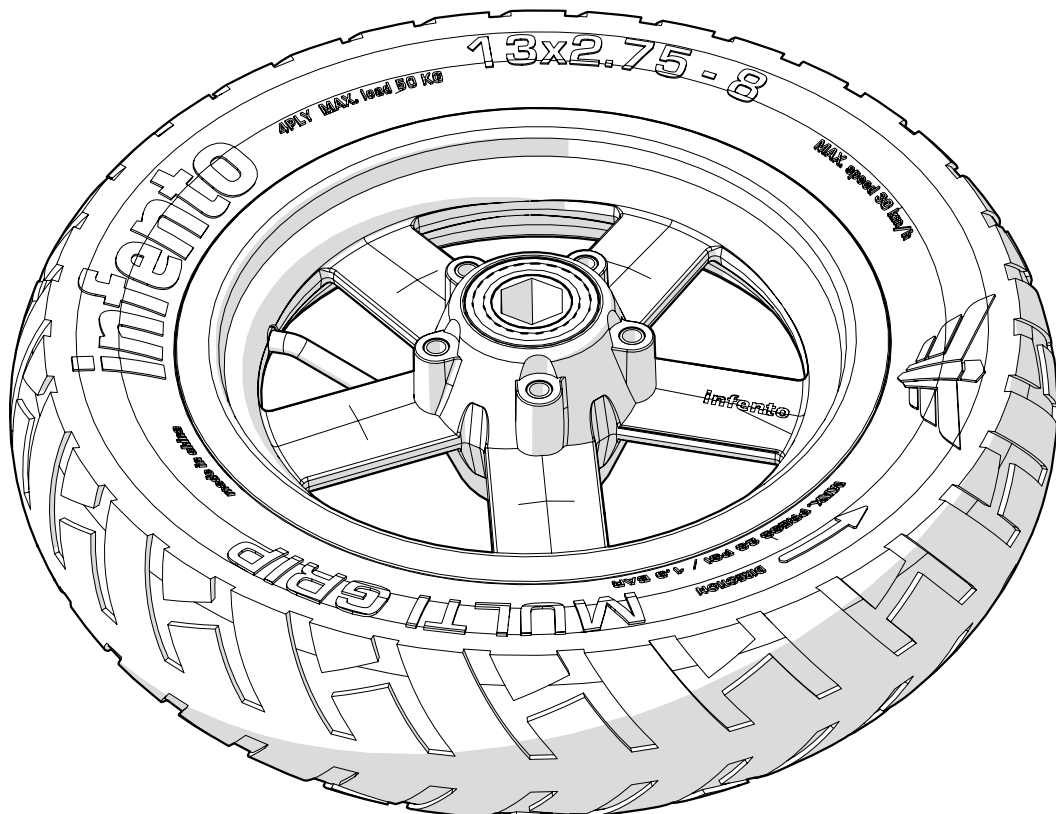
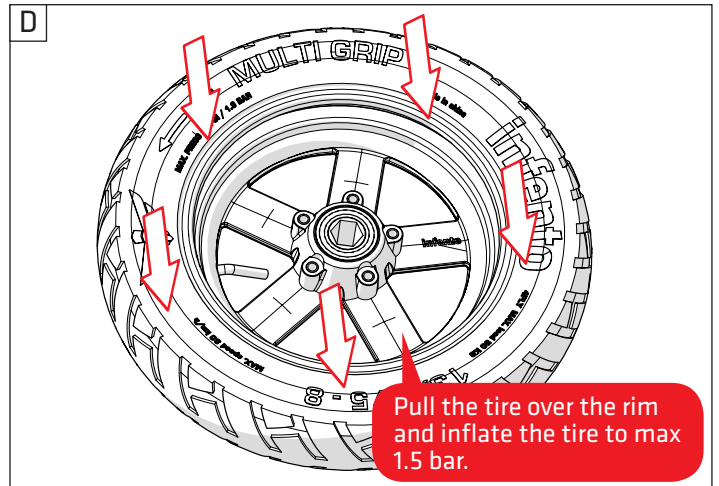
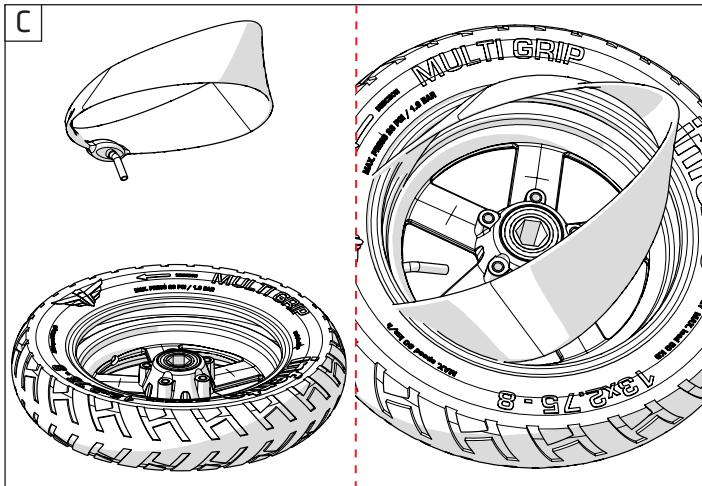
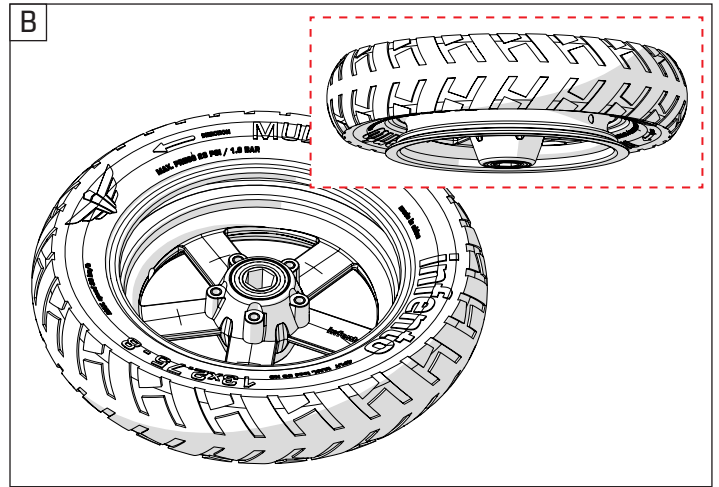
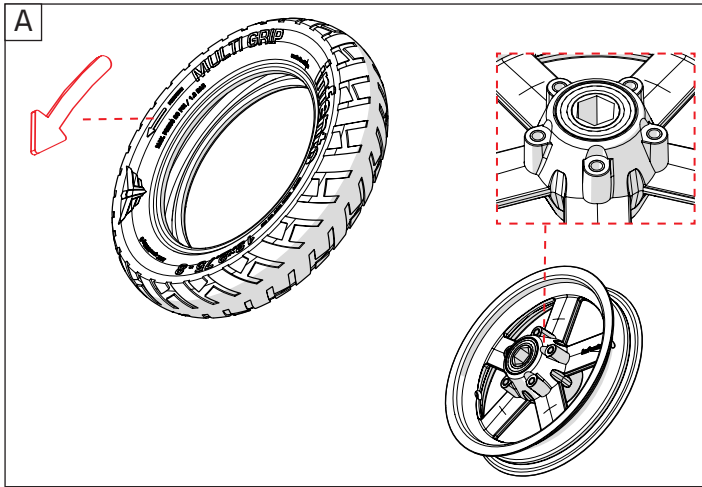



18

ride BULLDOG

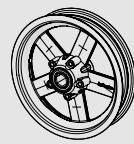

8 inch
Free spinning rim

+

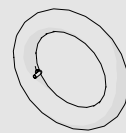

Inner tube
13x2.75-8

+



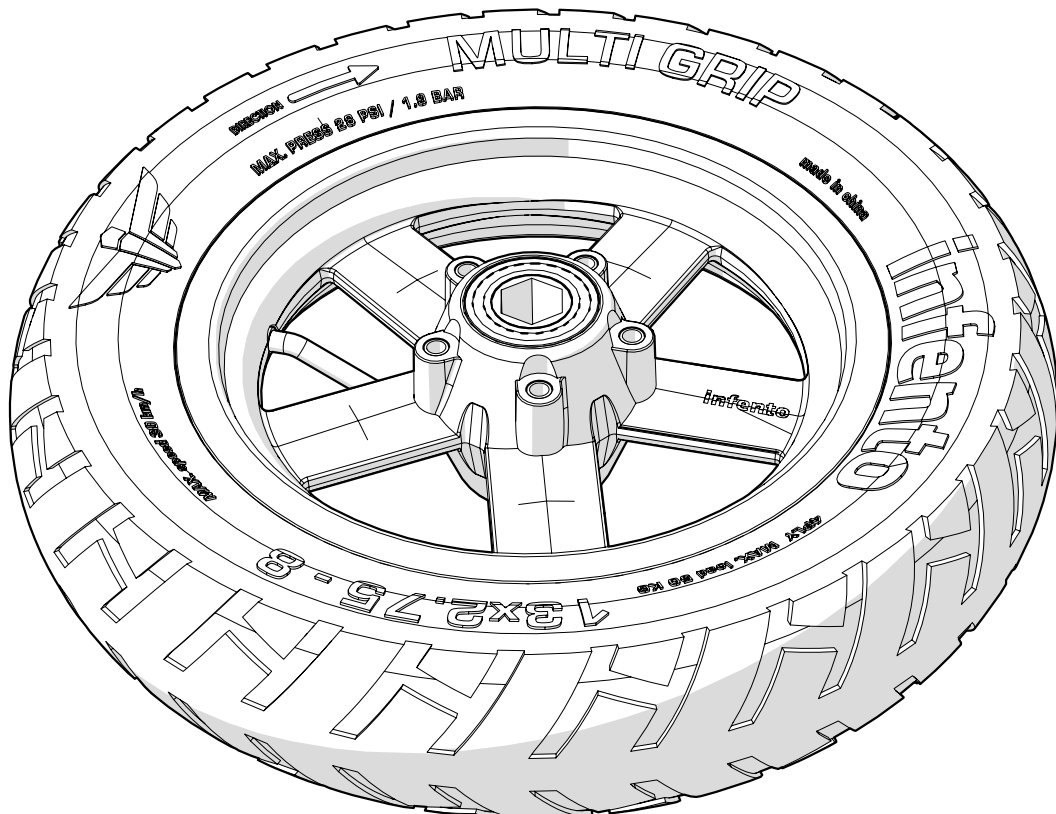
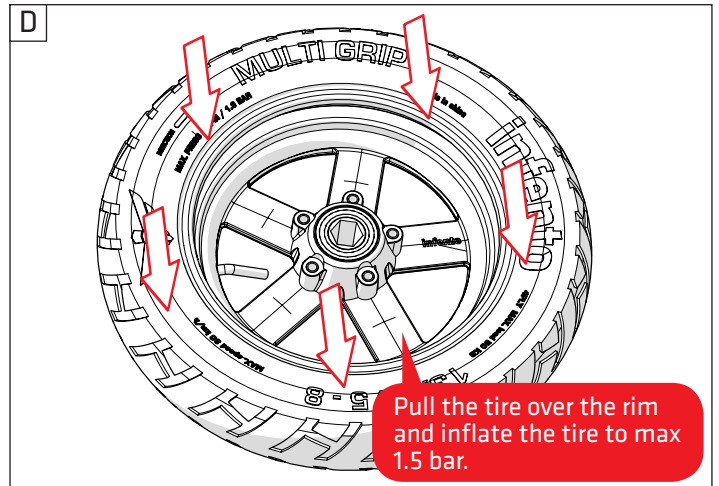
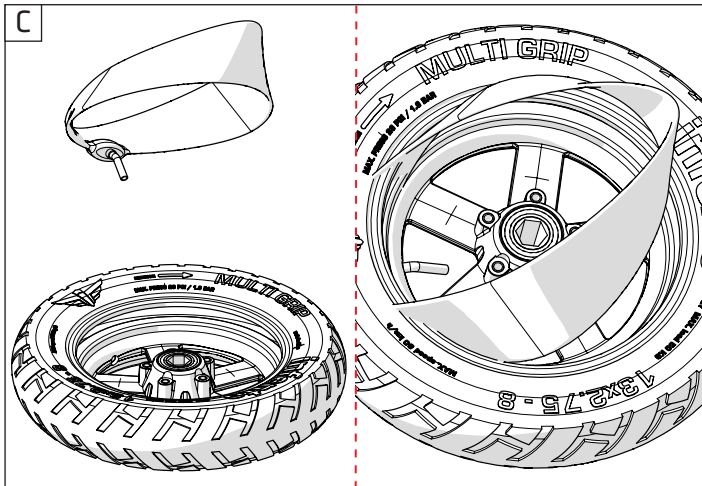
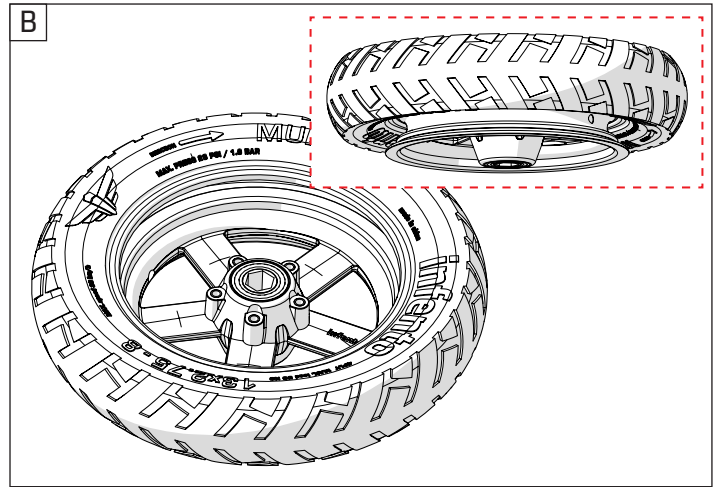
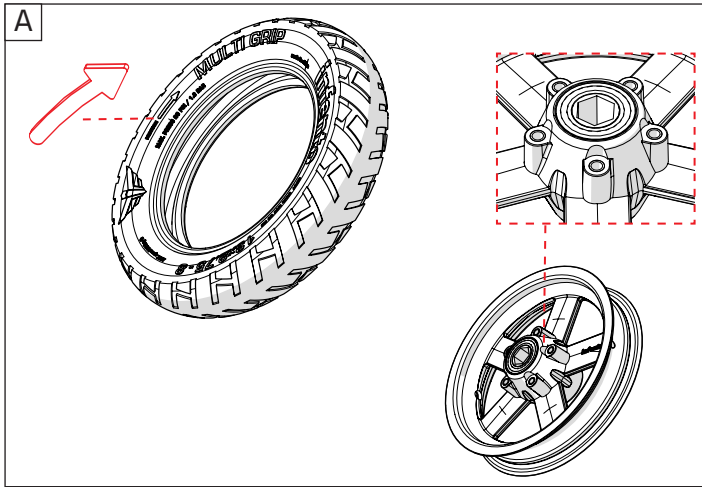

Tire
13x2.75-8



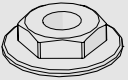

19

ride **BULLDOG**

-  2x
-  2x
-  2x

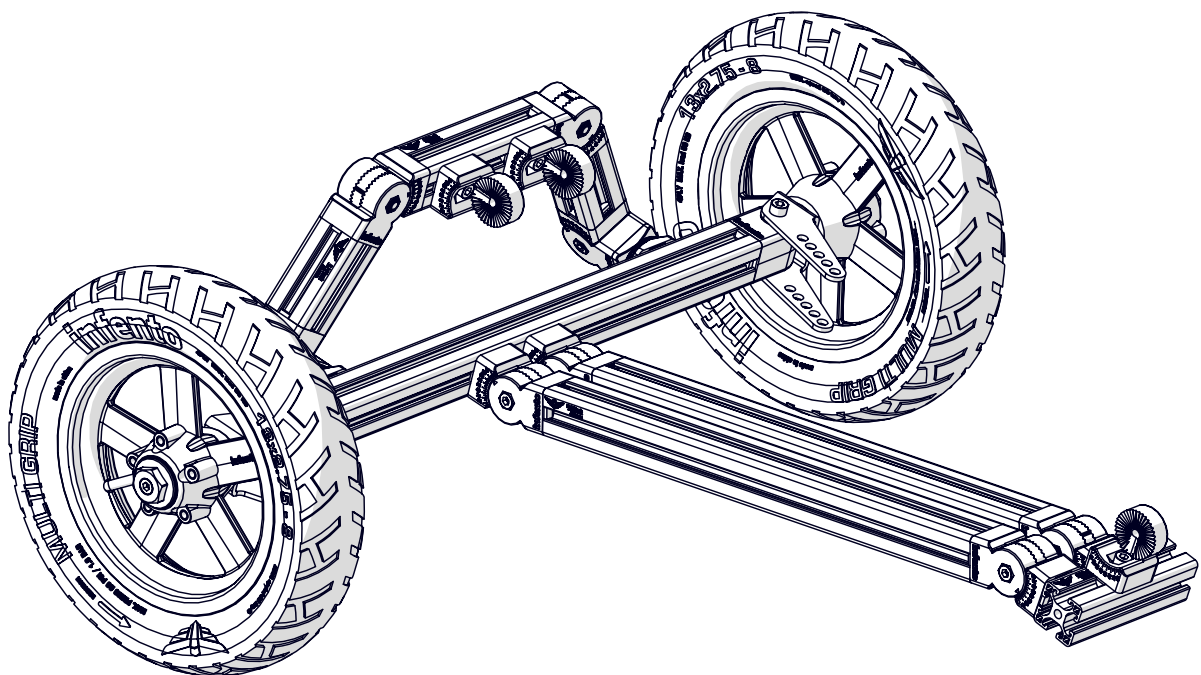
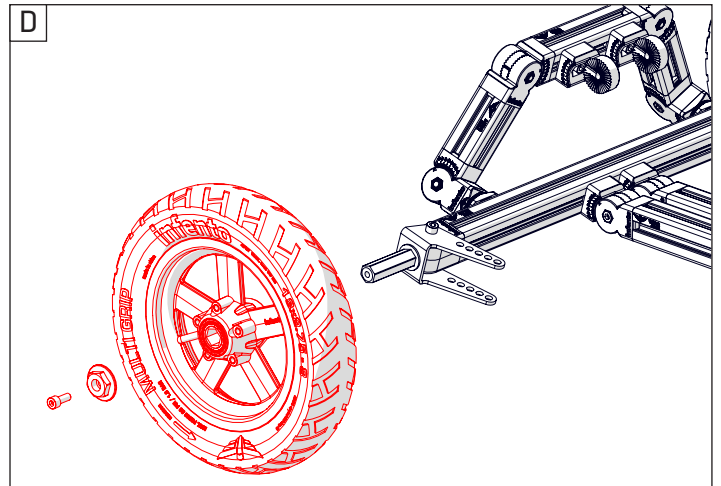
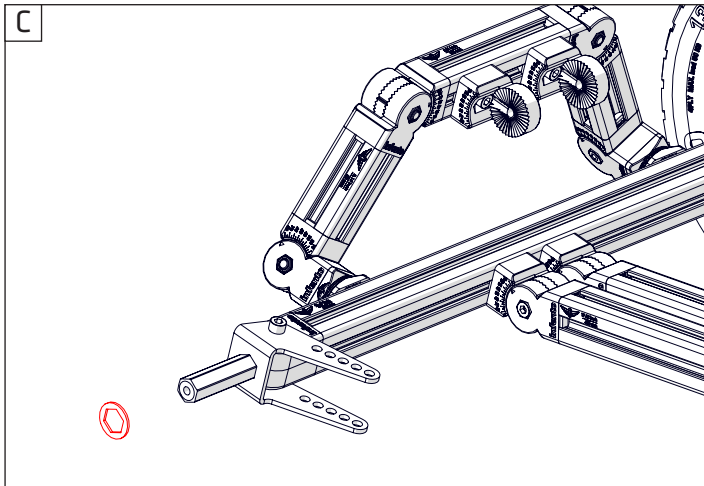
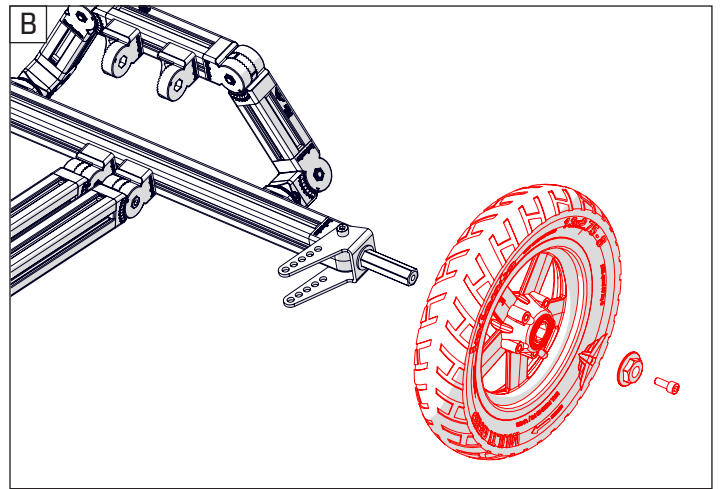
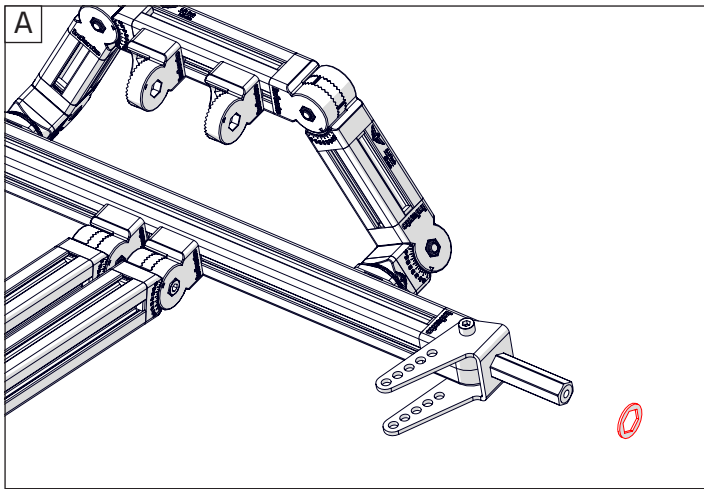



20

ride **BULLDOG**

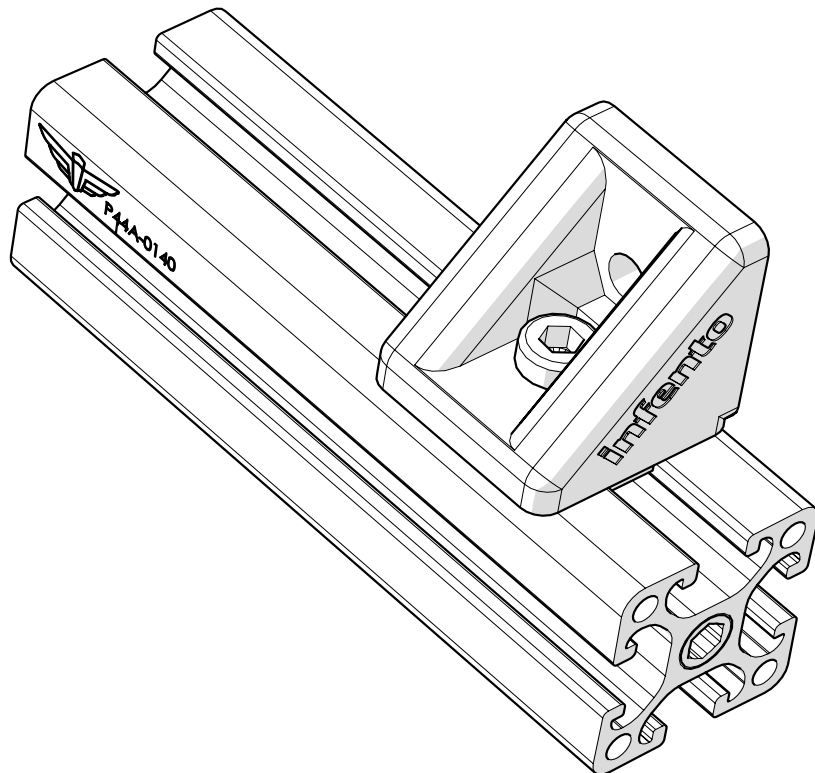
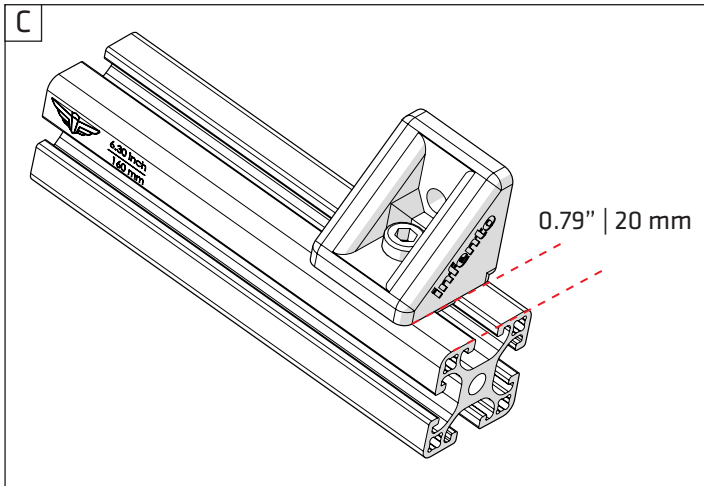
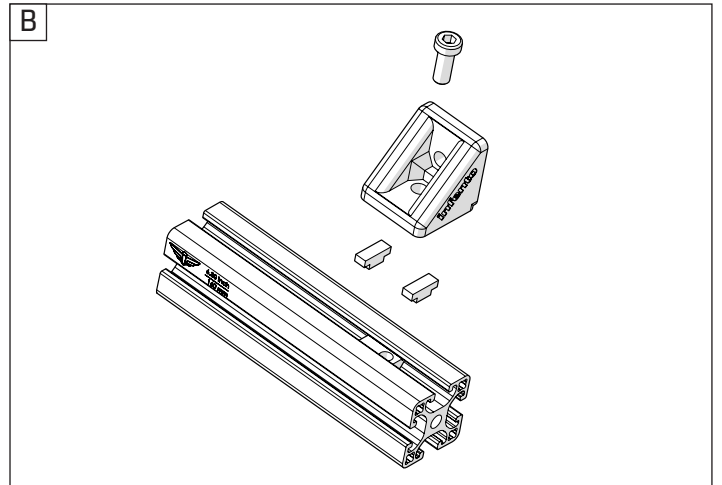
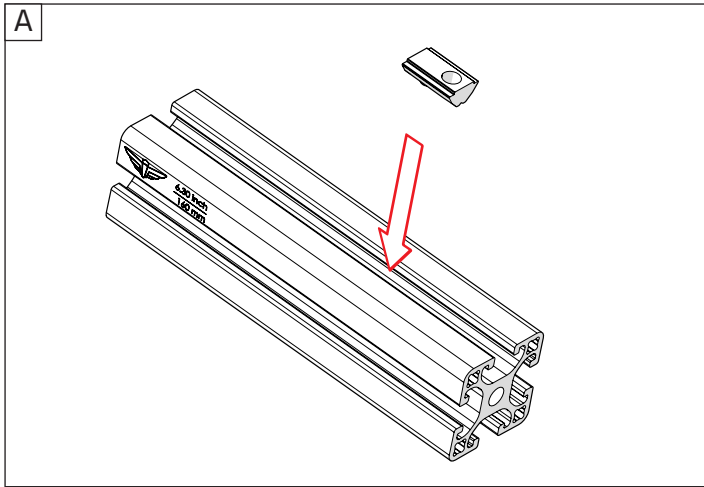

- Bolt M8x20 (low head) 1x
- T-Positioning block 2x
- Profile nut short 1x
- L-joint 1x
- Profile 6.30inch | 160mm 1x





21

ride **BULLDOG**

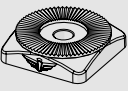
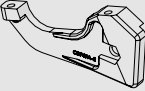

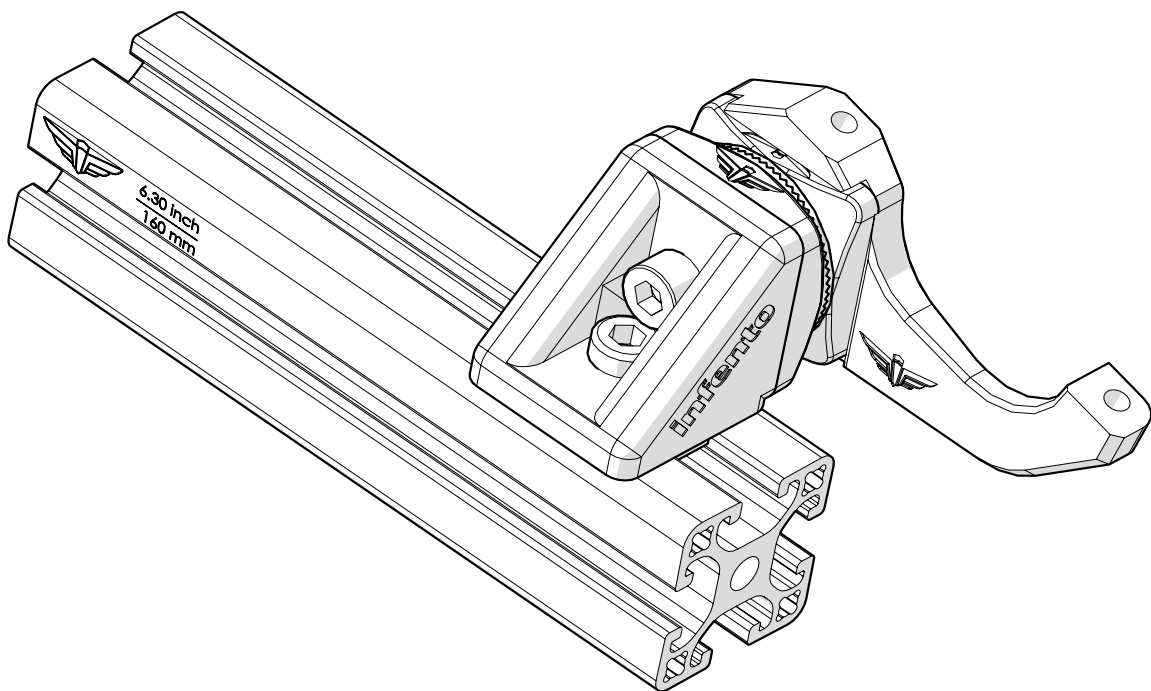
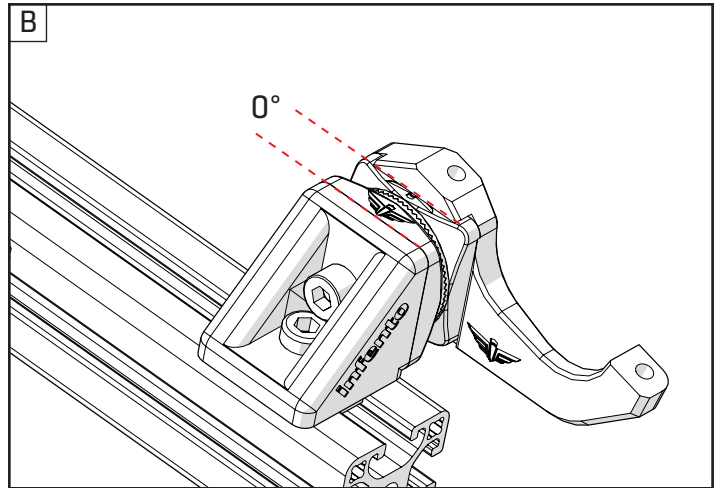
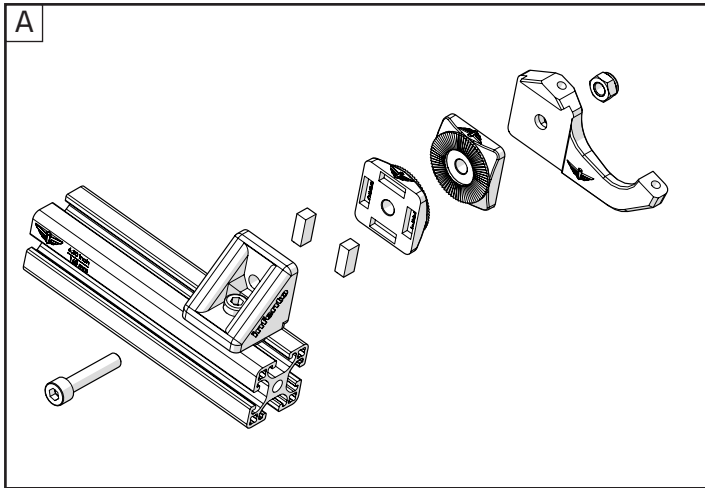

- 
Positioning block 2x
- 
Locknut M8 1x
- 
Bolt M8x40 1x
- 
Swivel plate 40x40 2x
- 
Brake caliper holder 1x





22

ride BULLDOG

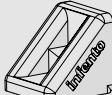
-  1x
-  4x
-  1x
-  1x
-  1x

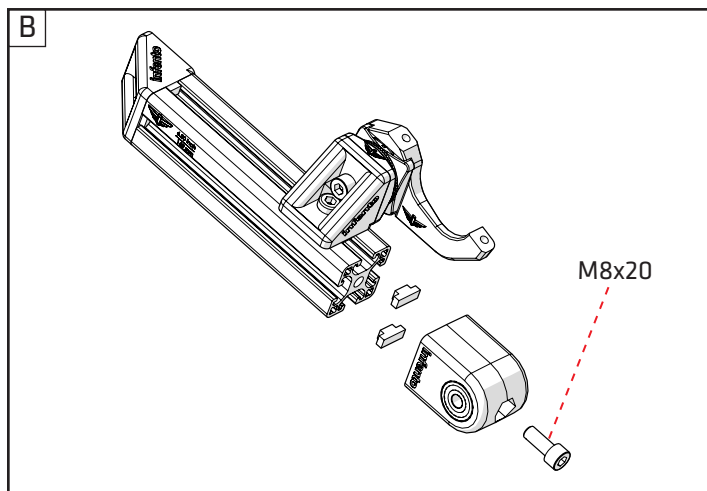
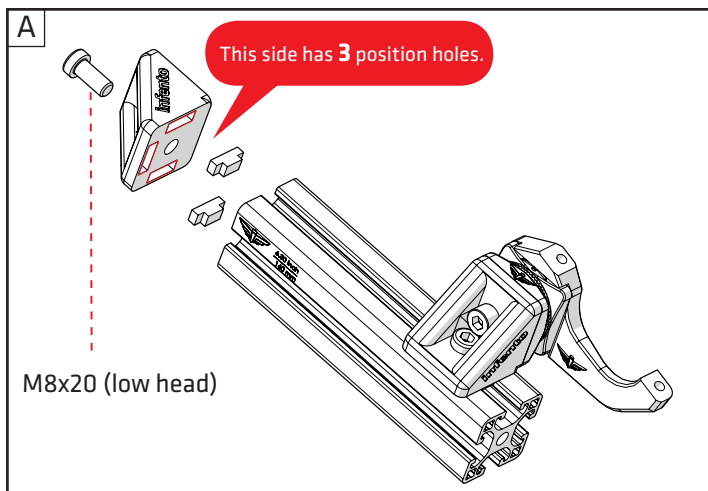

Use the Allen key handle so you can tighten the bolt well.

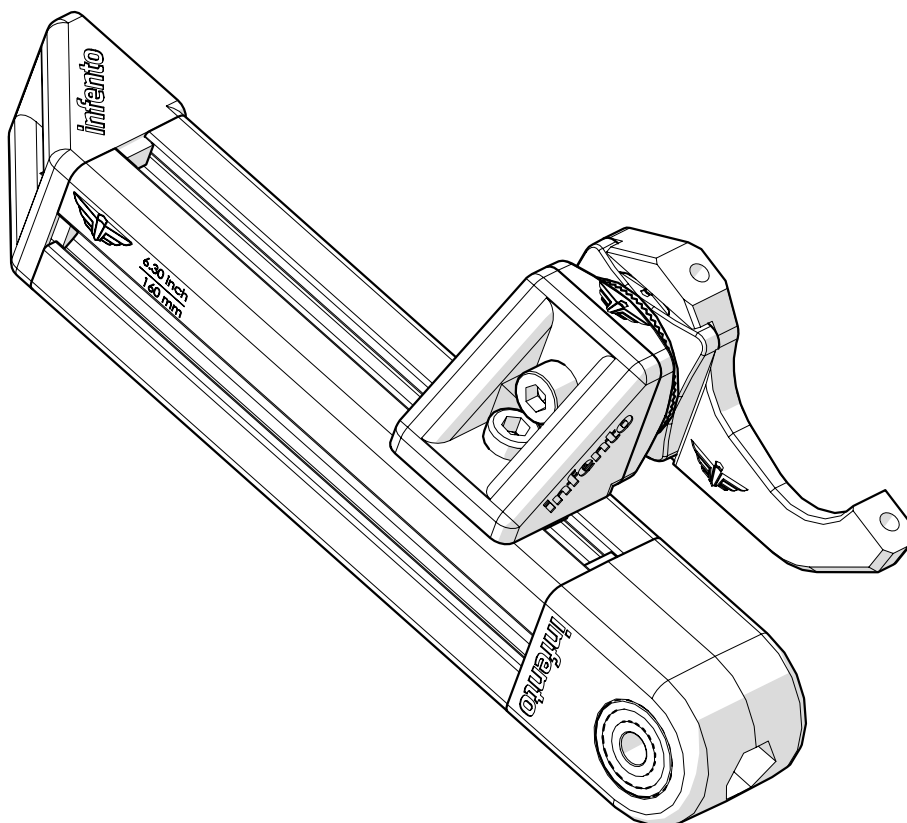
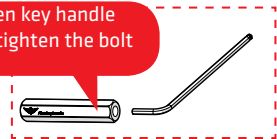



23

ride **BULLDOG**



+



T-Positioning block 3x

Bolt M8x20 1x
(low head)

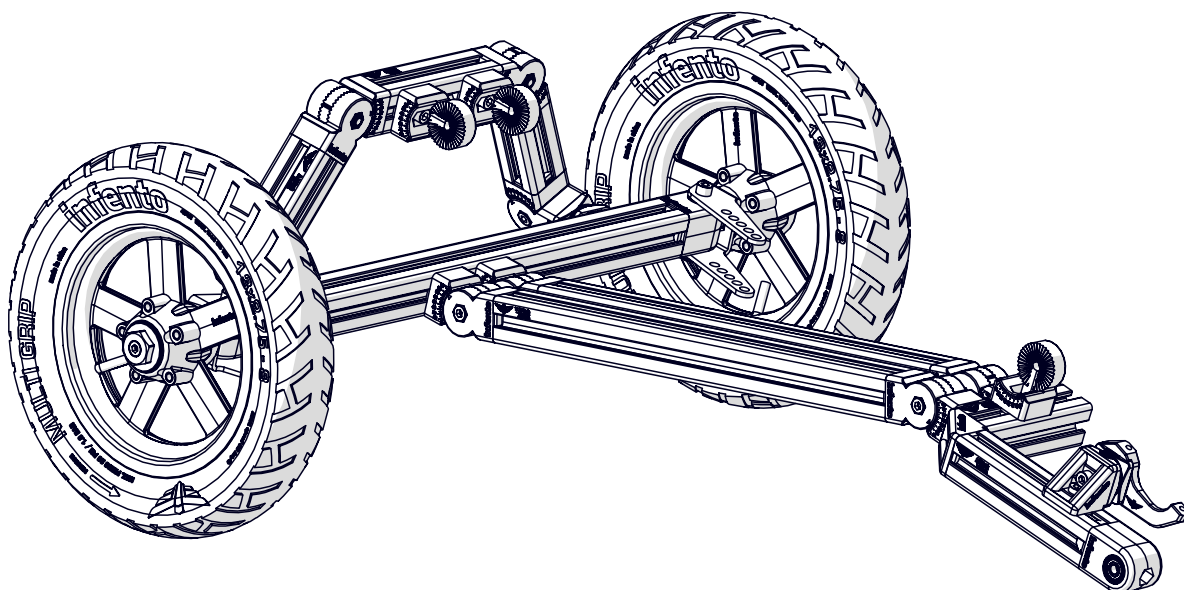
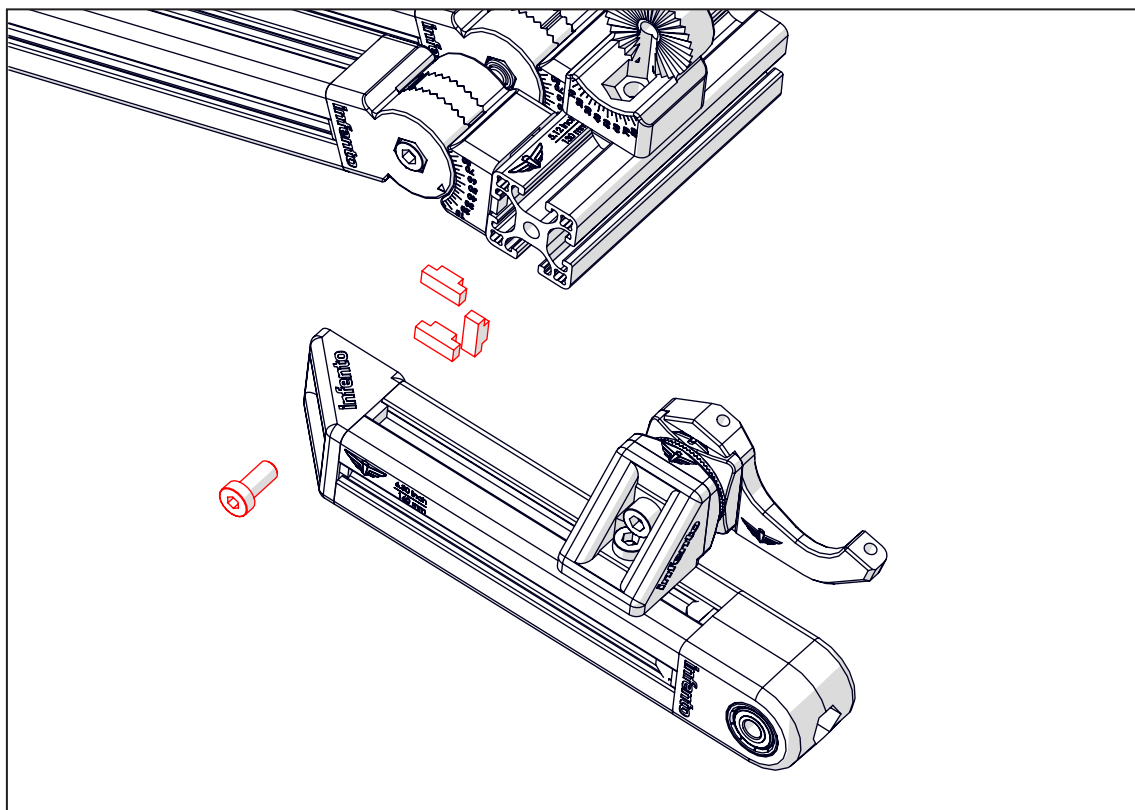



24

ride BULLDOG



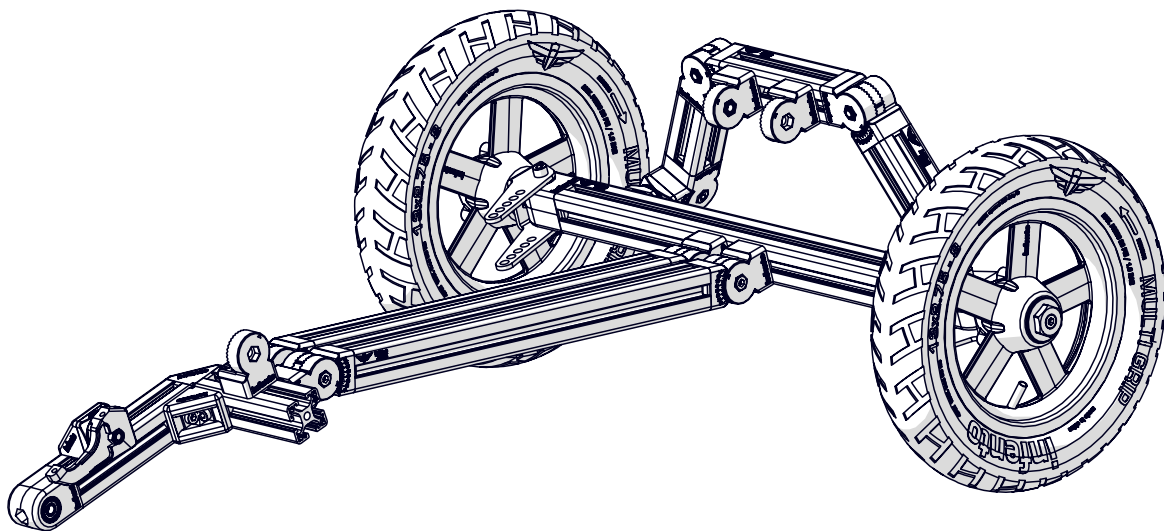
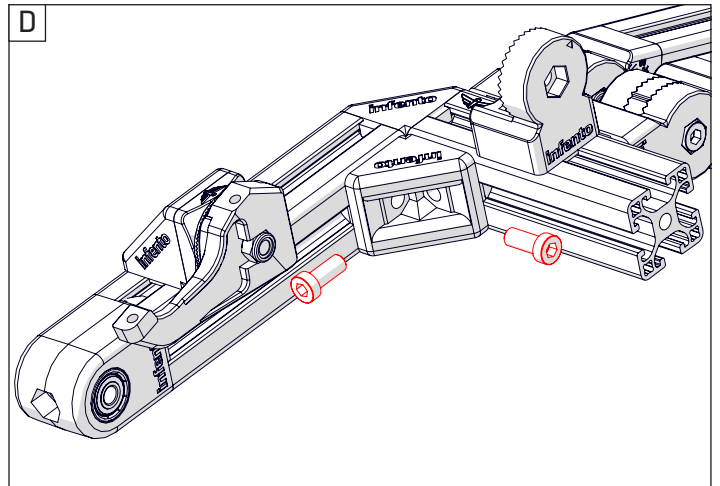
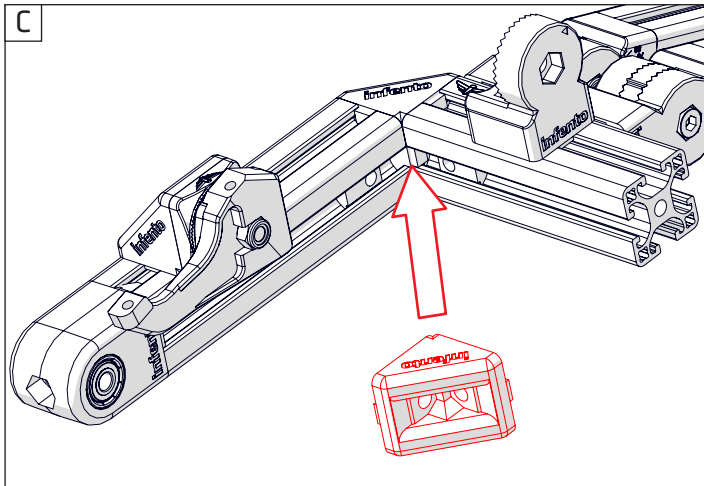
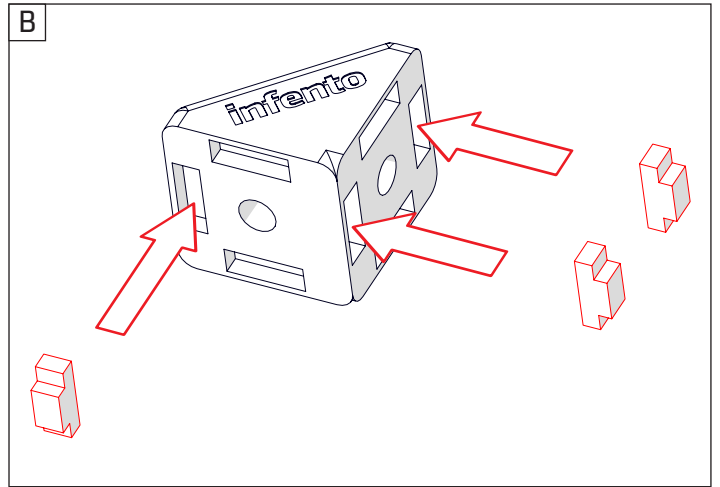
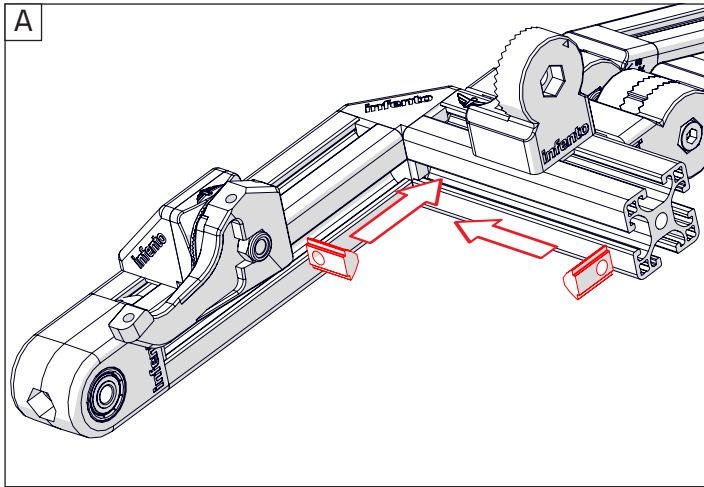

-  3x
-  2x
-  2x
-  1x





25

ride BULLDOG

- 
Bolt M8x60 1x
- +
- 
Washer M8-16 1x
- +
- 
Washer M8-24 1x
- +
- 
Axle 4.8inch | 122mm 1x

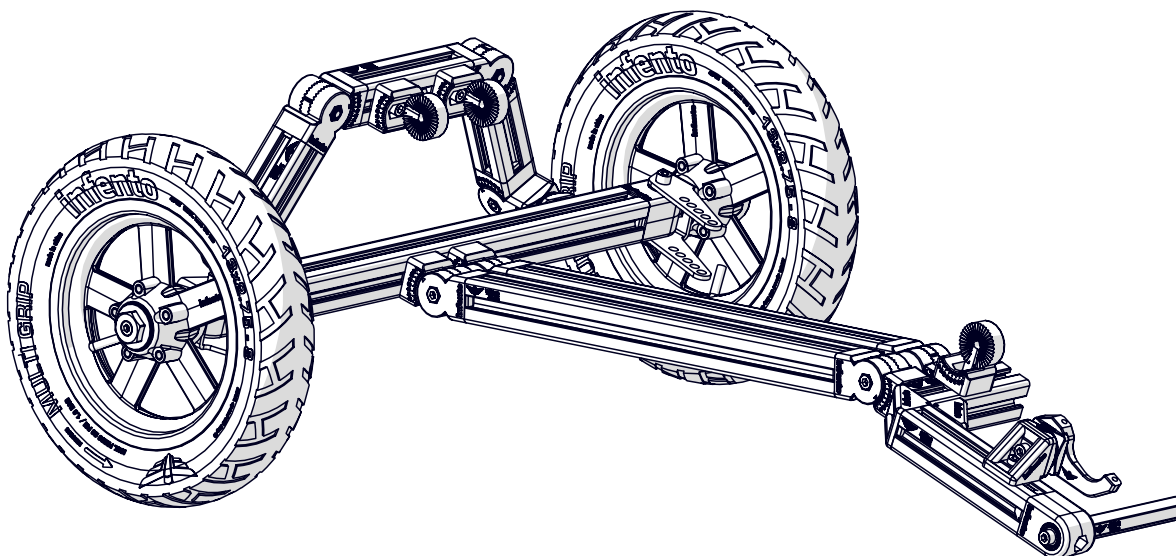
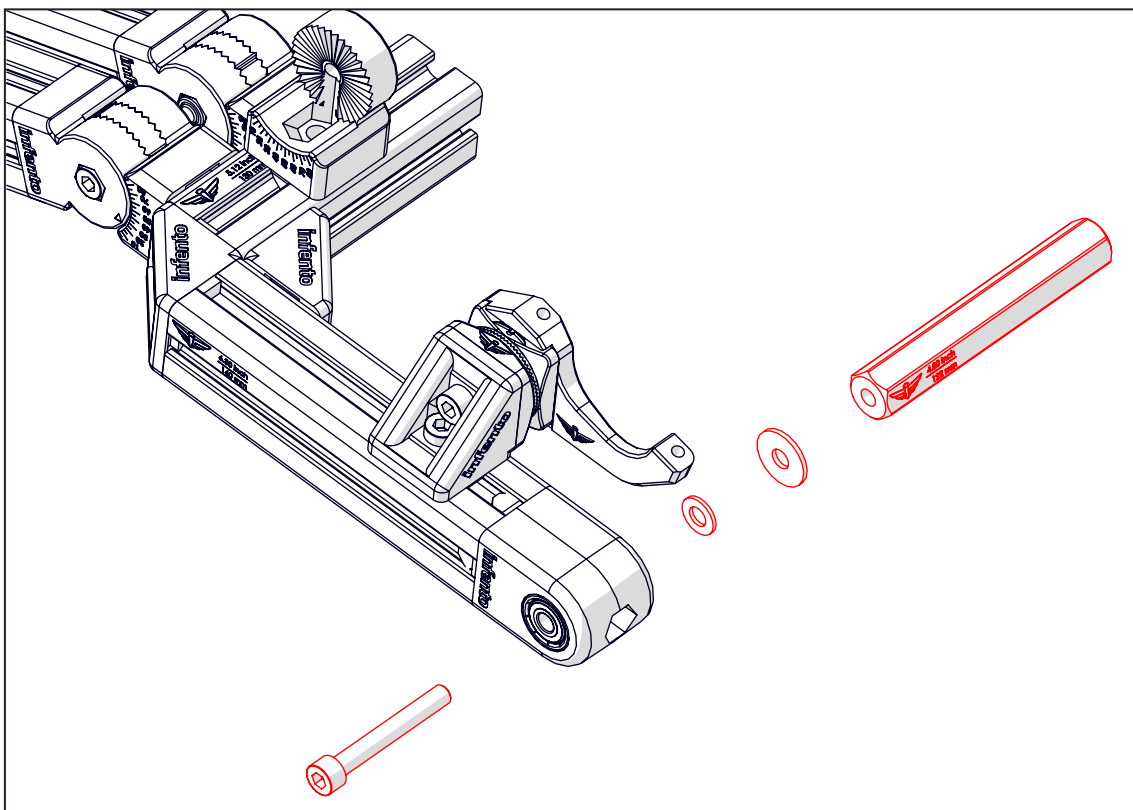



26

ride BULLDOG

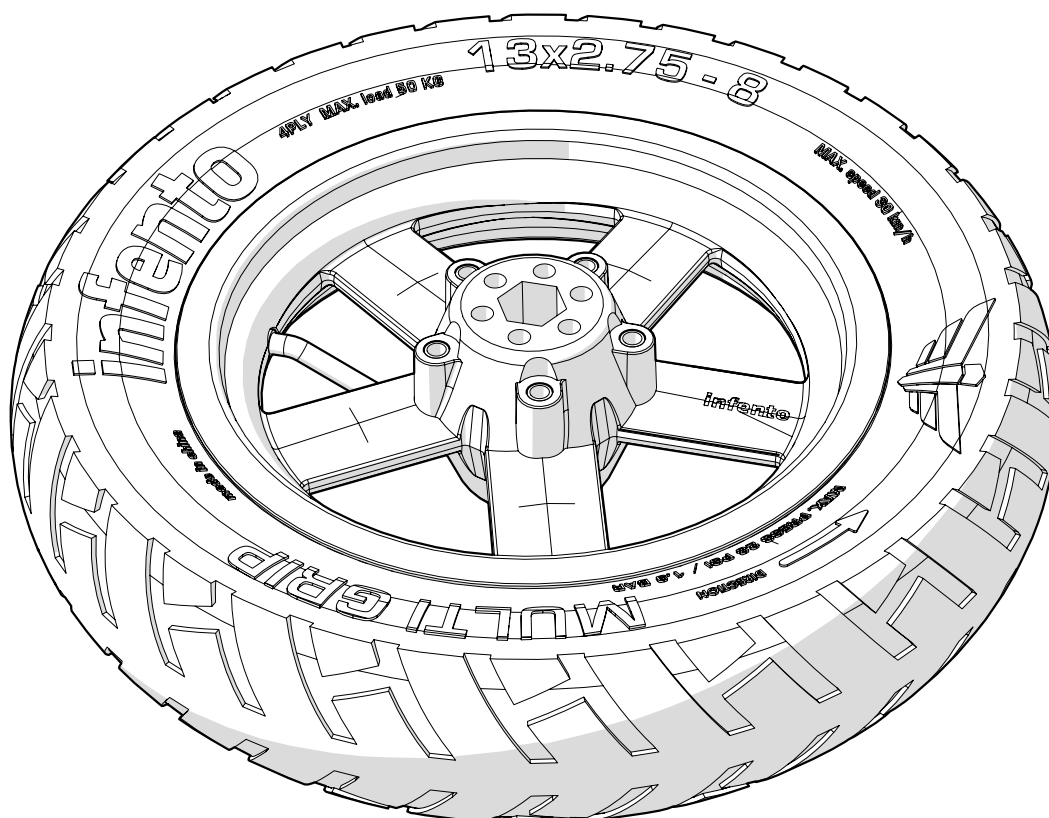
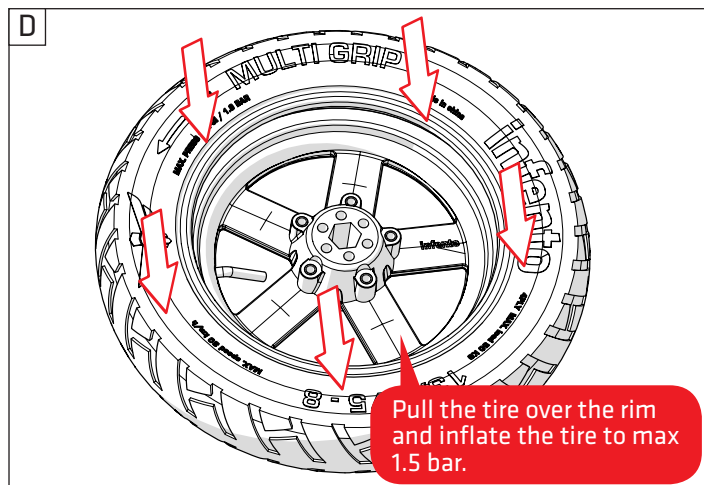
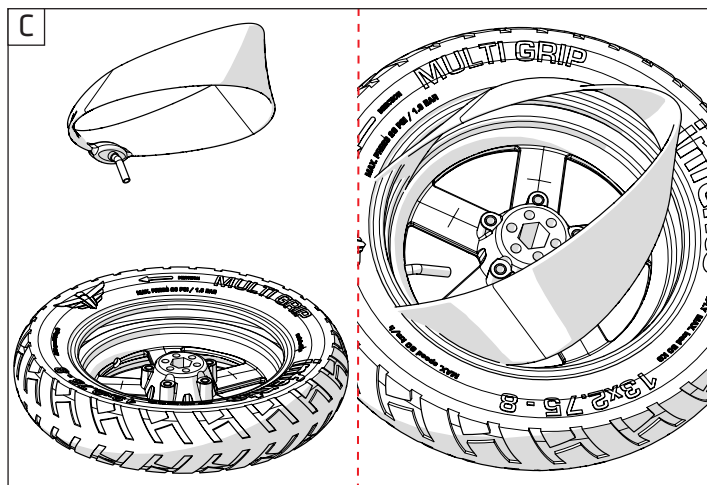
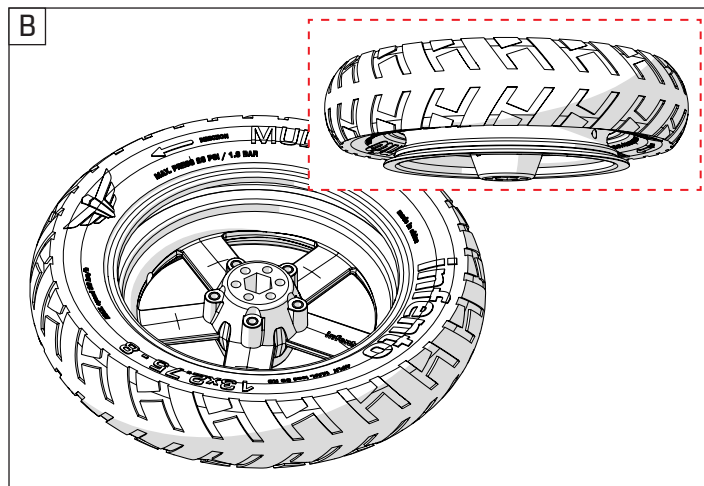
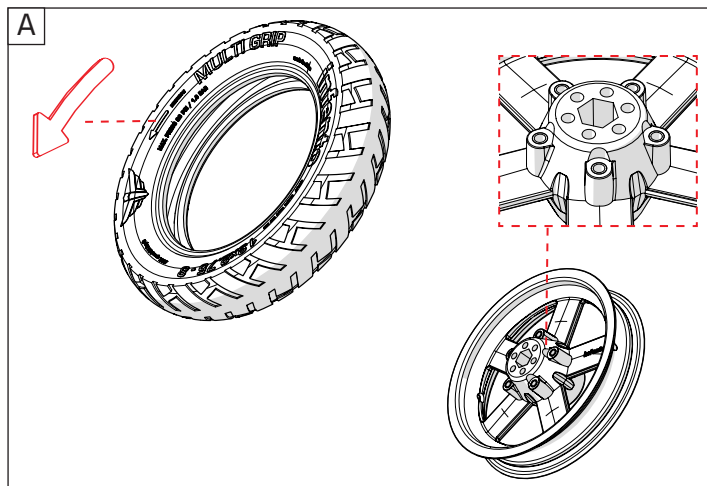



27

ride BULLDOG

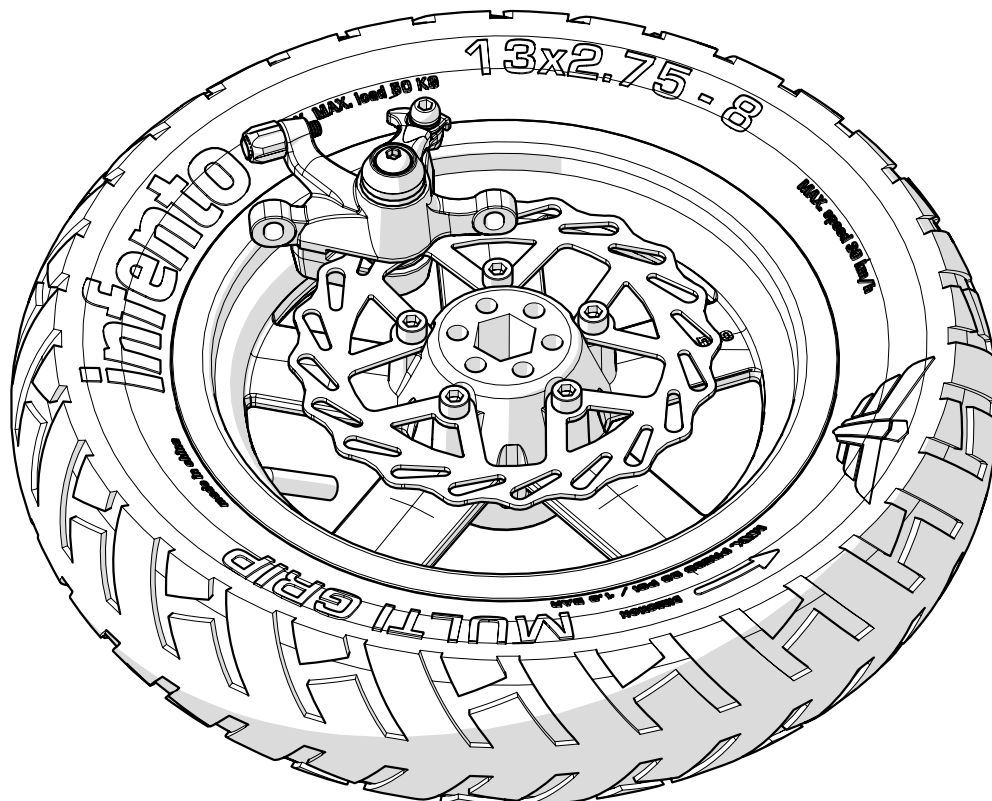
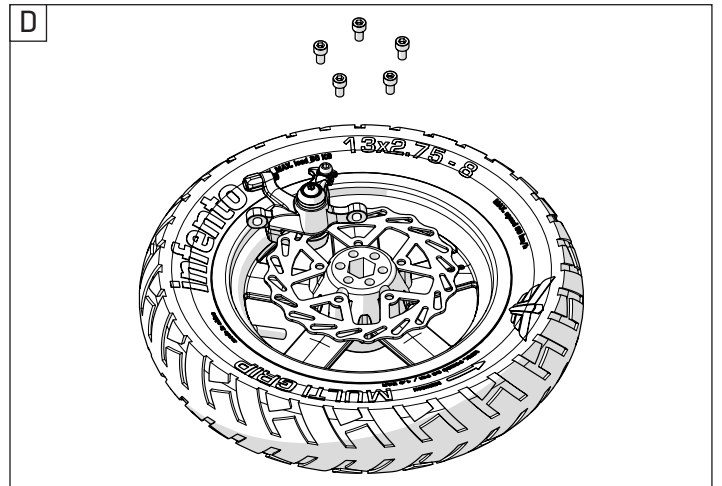
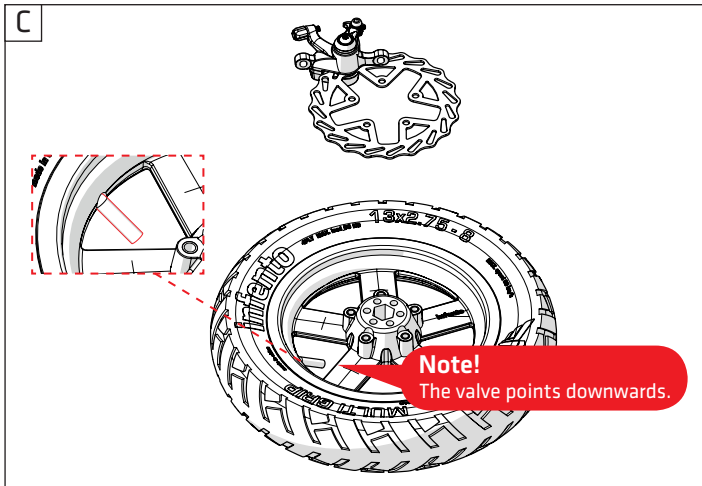
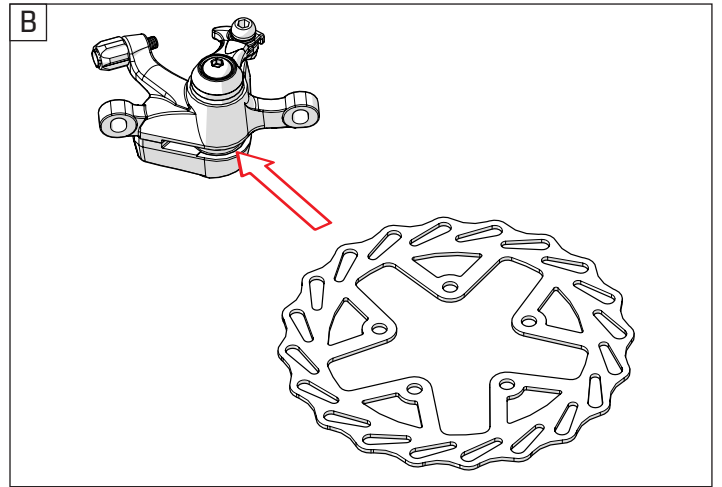
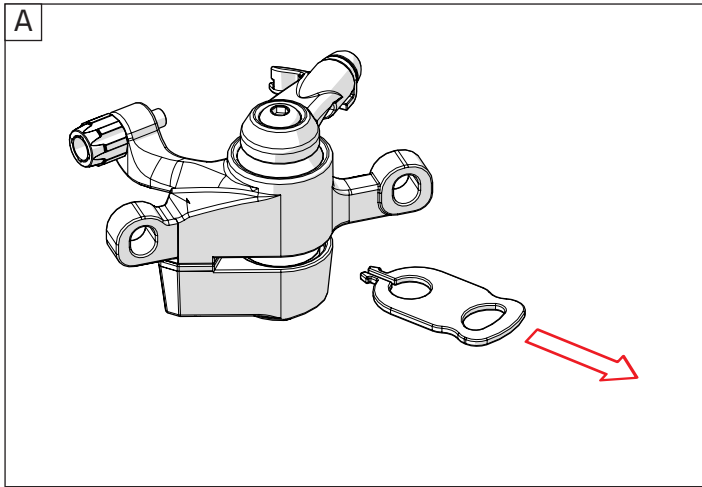
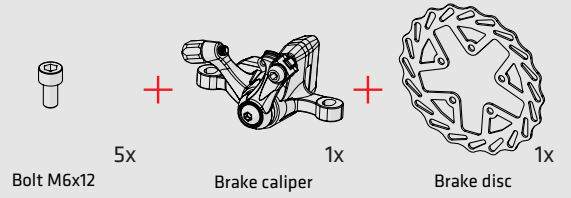



28

ride BULLDOG

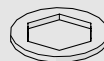

+



Spacer 1x
0.08inch | 2 mm

Spacer 2x
0.39inch | 10mm

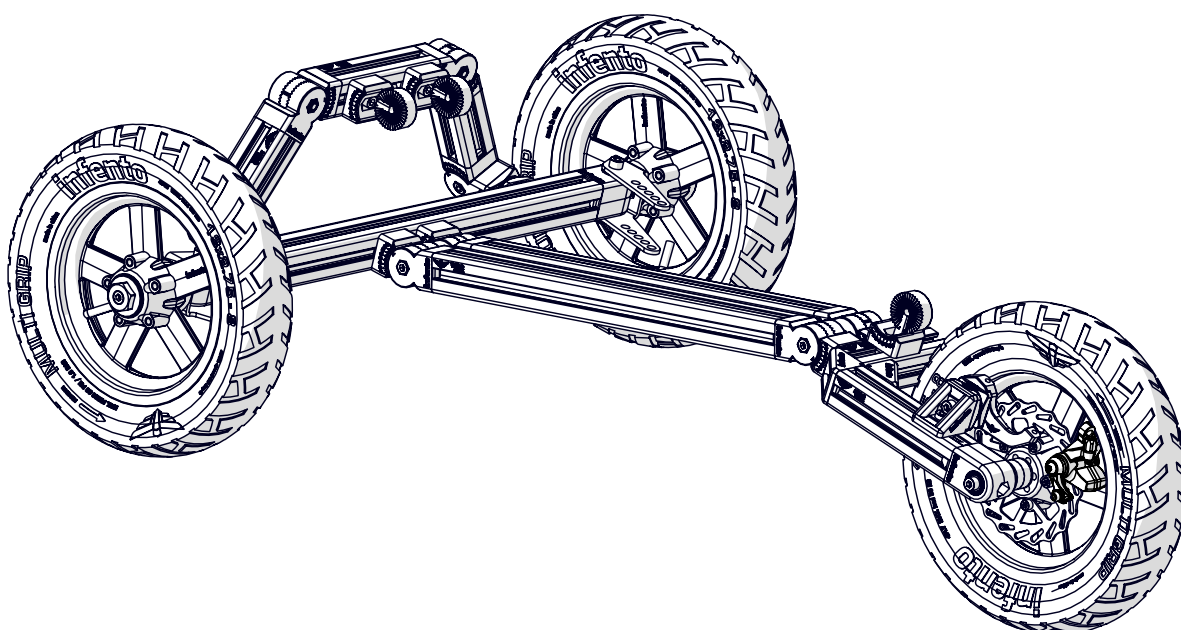
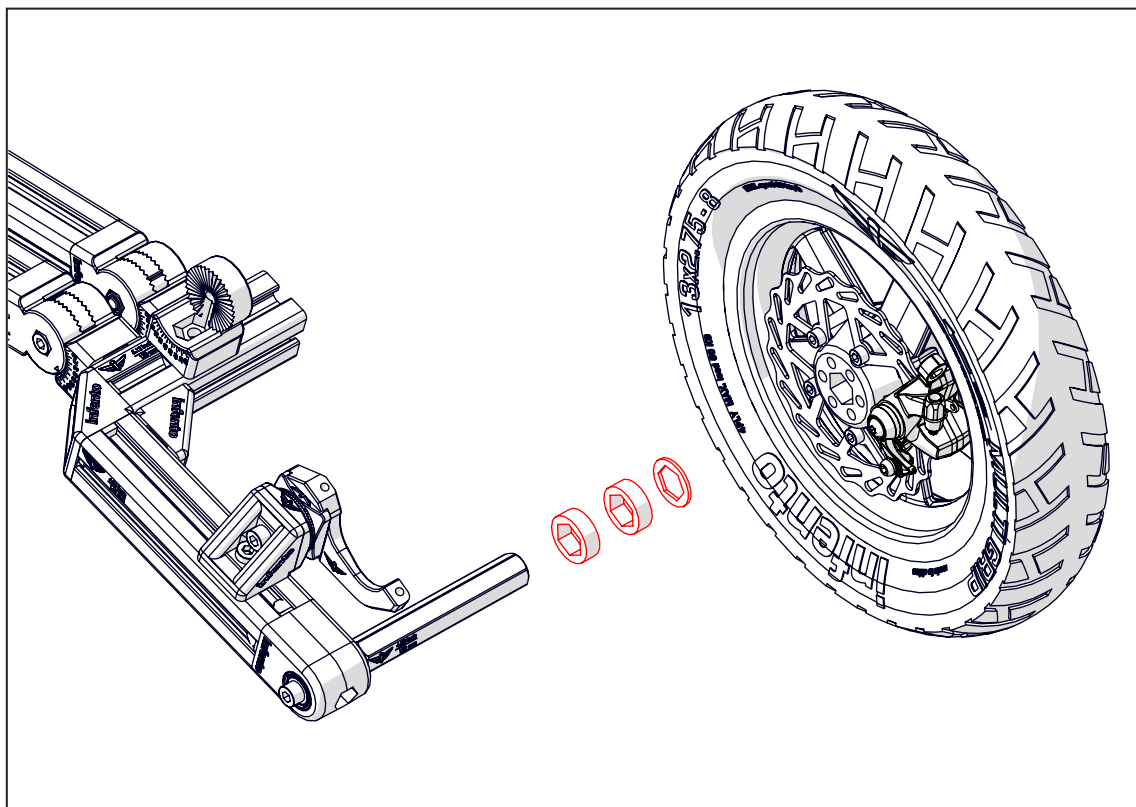



29

ride **BULLDOG**



+



Conical spring
washer M6-10

2x

Bolt M6x16

2x

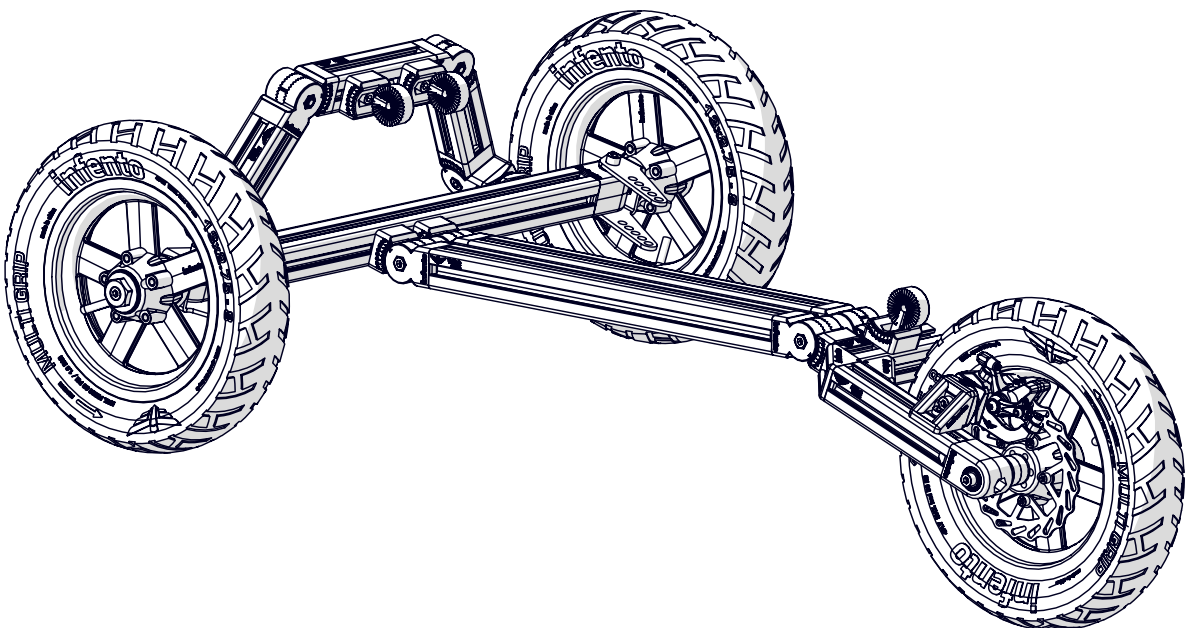
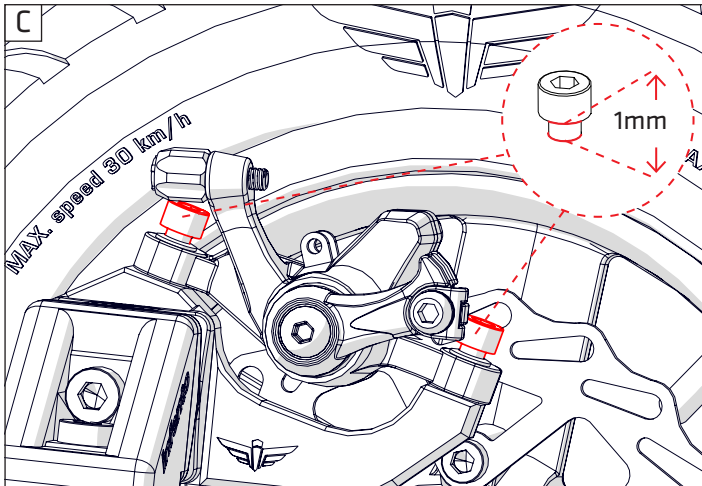
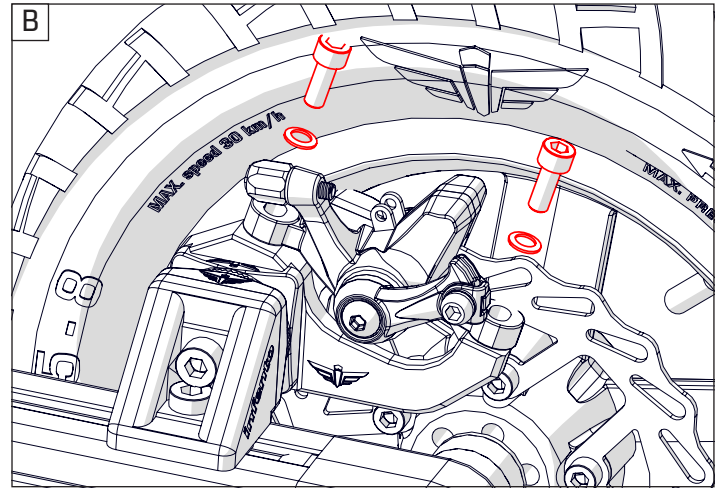
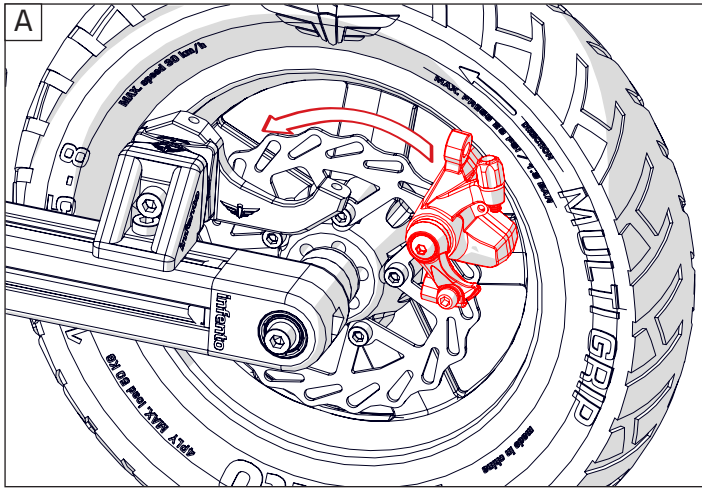



30

ride **BULLDOG**

- Bolt M8x20 (low head) 1x
- T-Positioning block 1x
- Profile nut short 1x
- L-joint 1x

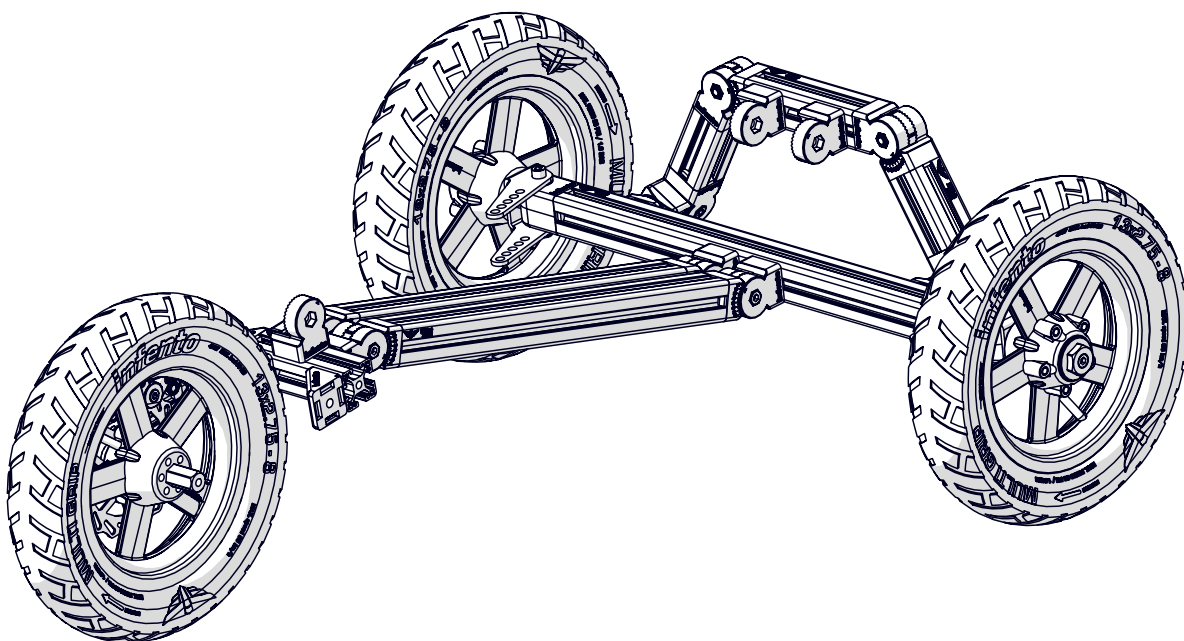
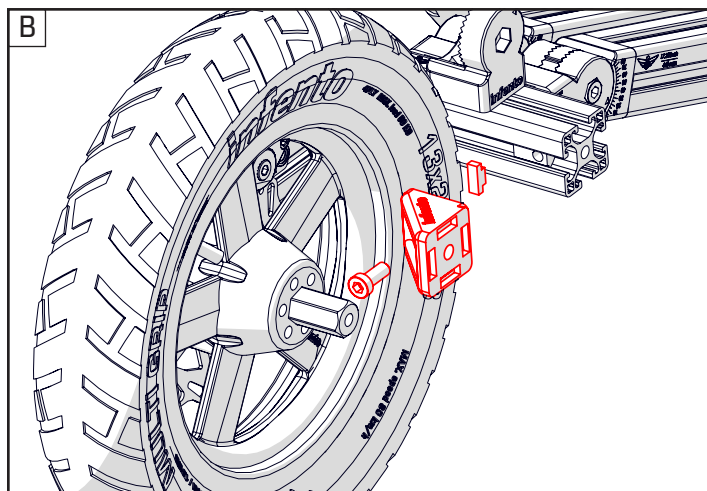
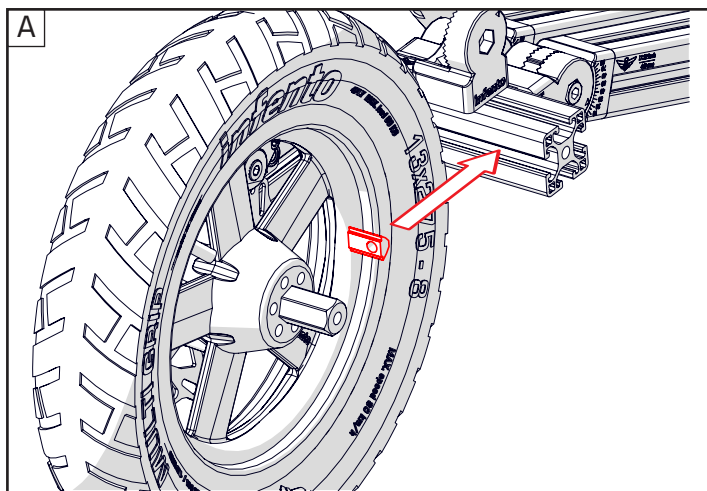



31

ride **BULLDOG**

Bolt M6x16

5x

Locknut M6



5x

Freewheel

1x

Toothed belt pulley 28T

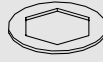
1x

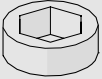
 +  + 

Spacer 1x
0.04inch | 1mm

Spacer 2x
0.08inch | 2mm

Spacer 1x
0.39inch | 10mm

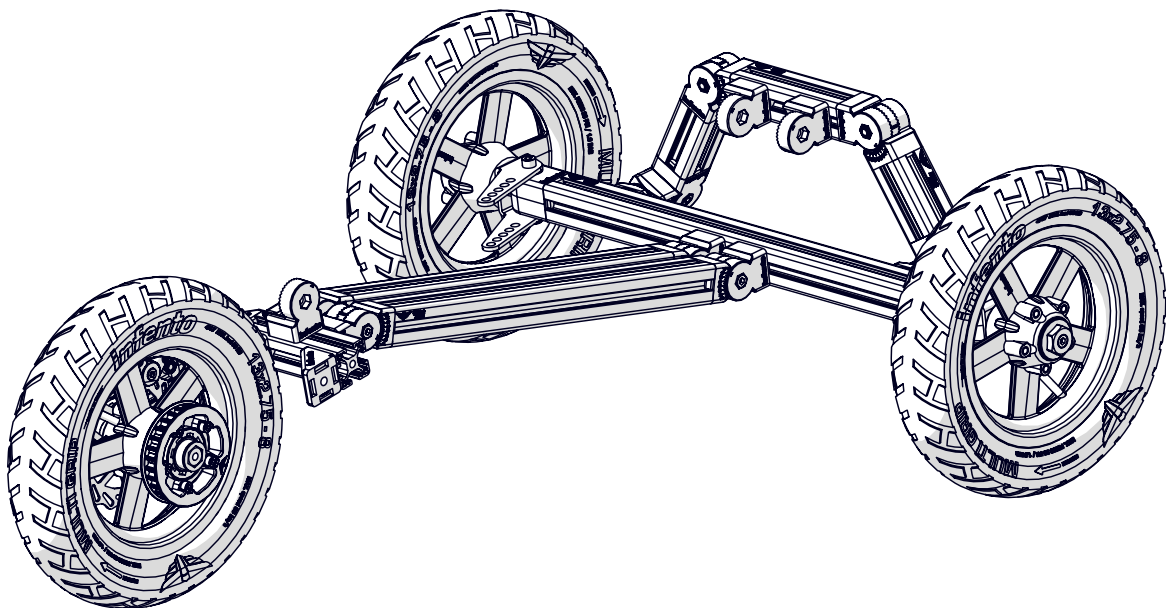
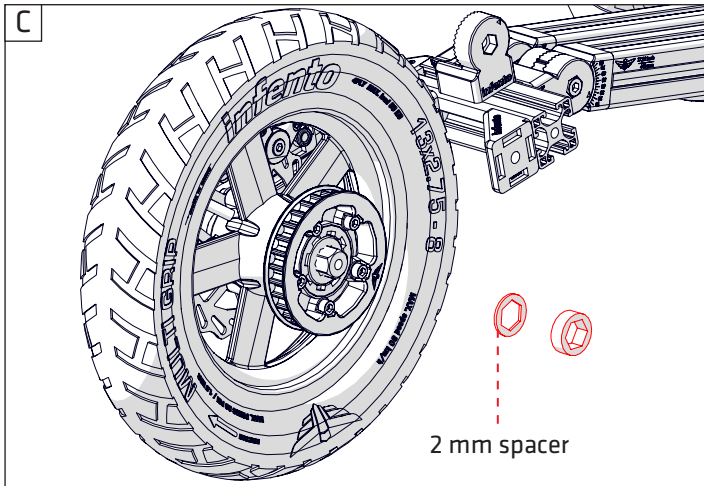
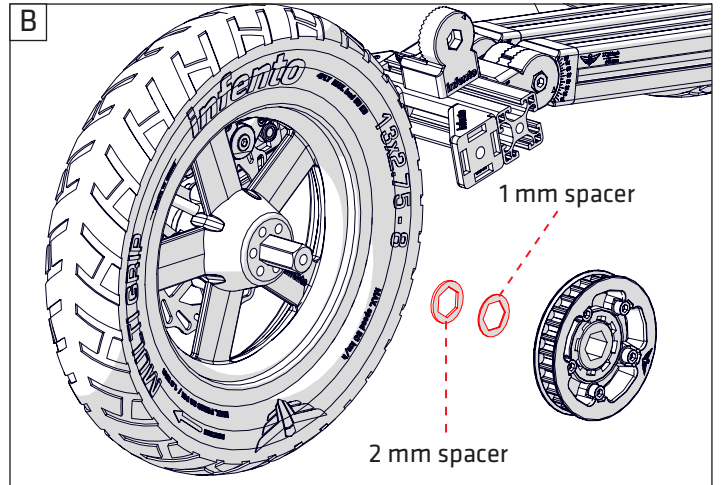
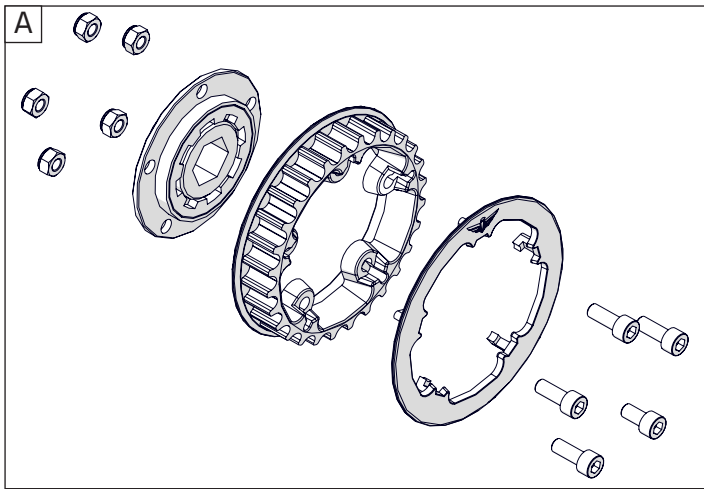



32

ride BULLDOG

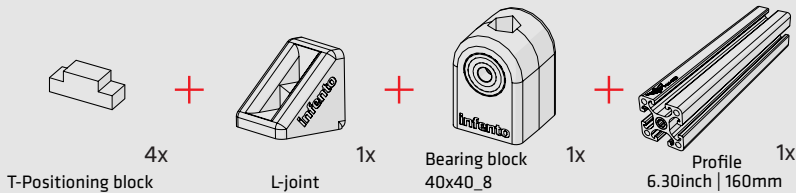

This side has 3 position holes.

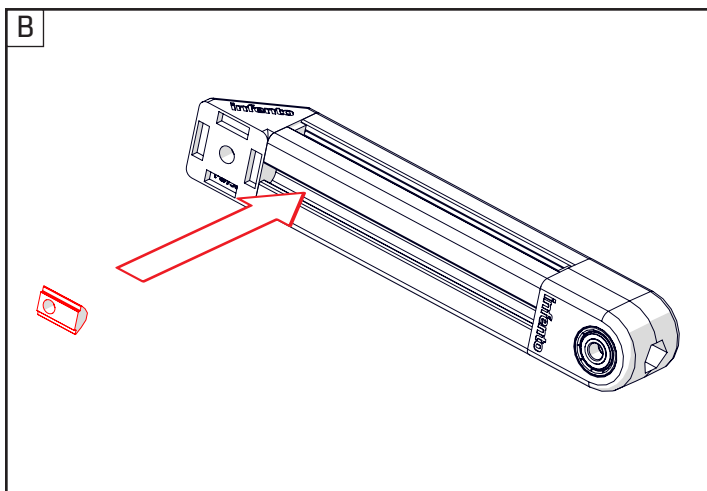
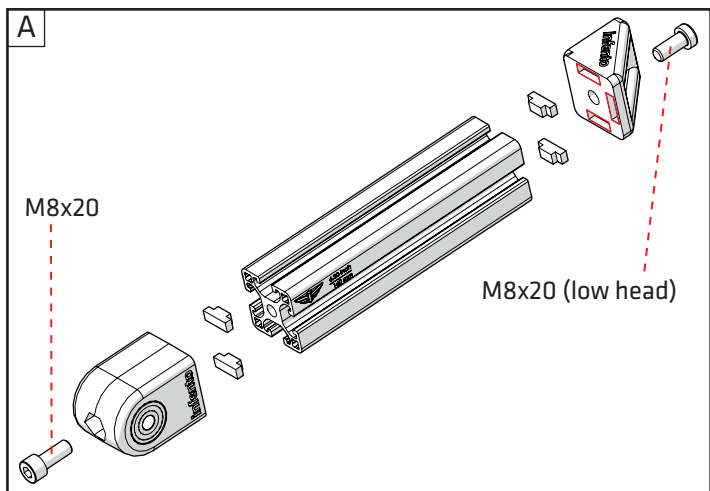
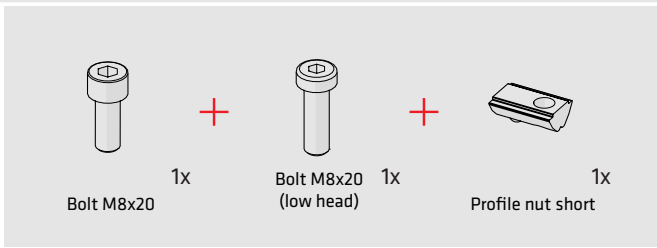



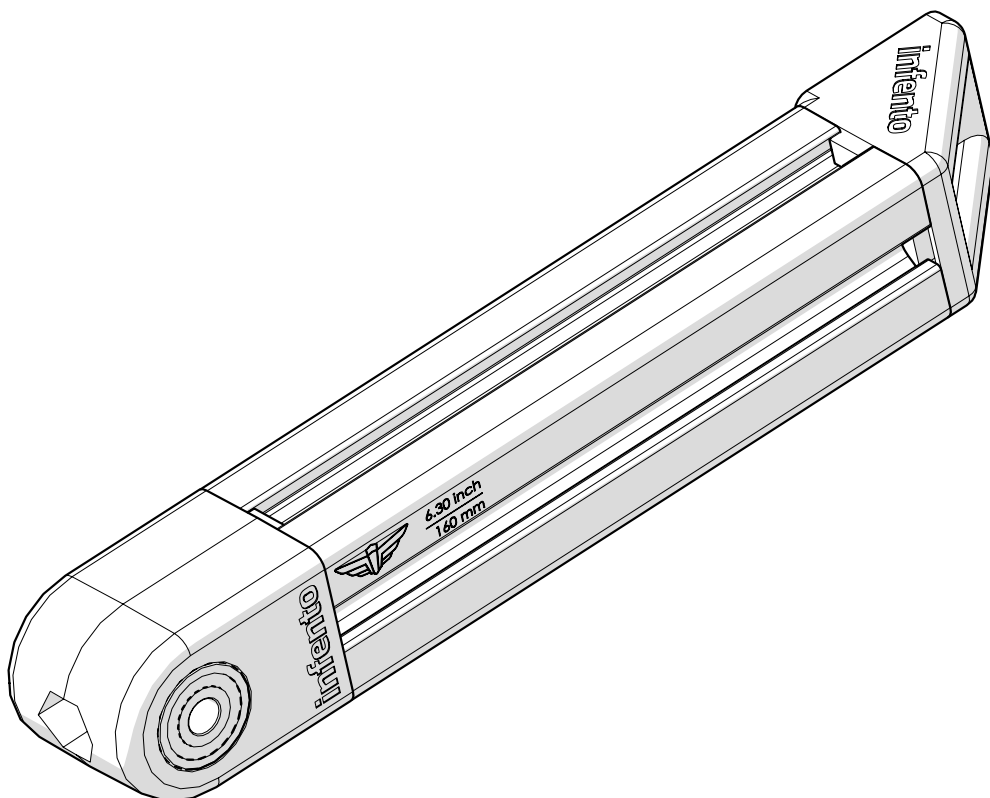
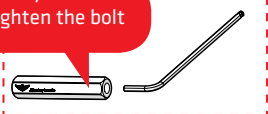

Use the Allen key handle so you can tighten the bolt well.





33

ride **BULLDOG**



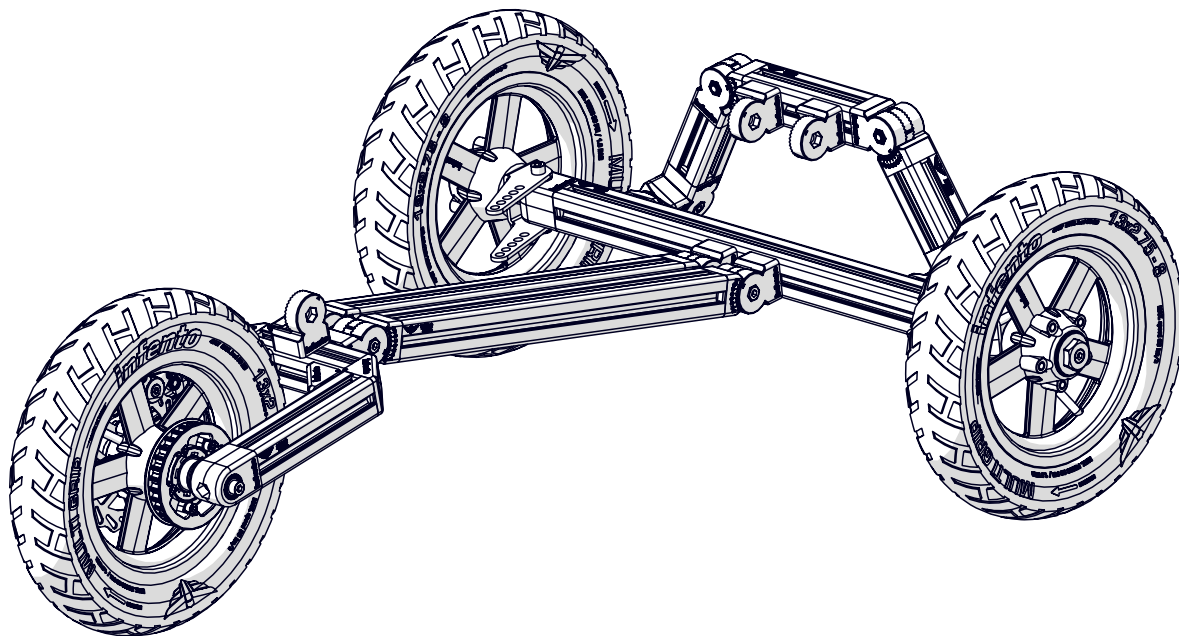
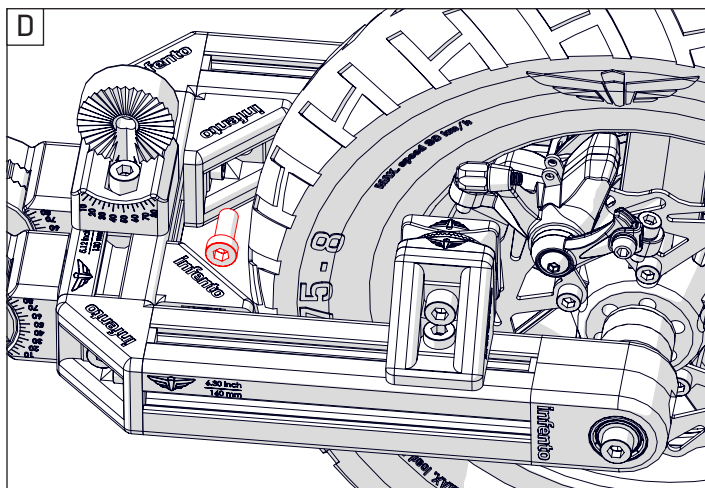
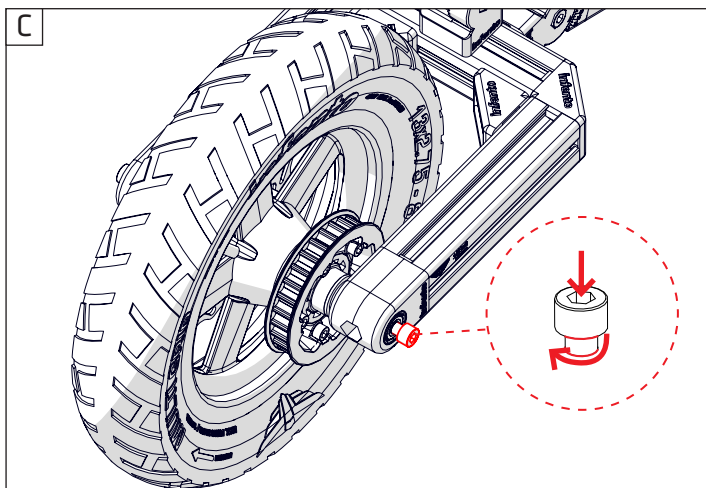
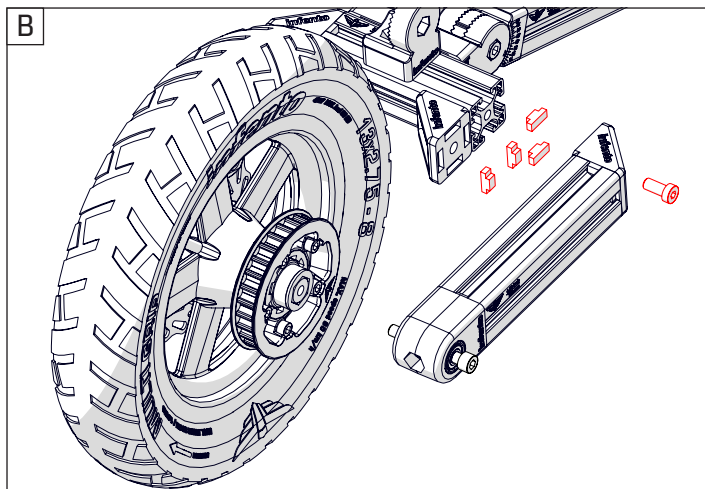
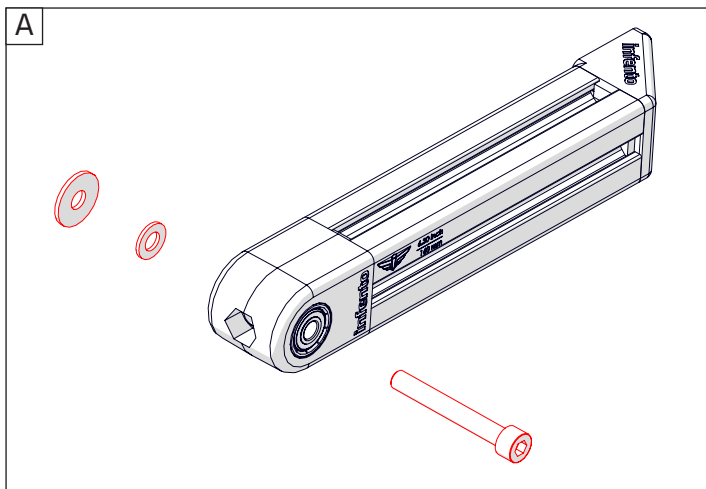

- 
4x
T-Positioning block
- 
2x
Bolt M8x20
(low head)
- 
1x
Bolt M8x60
- 
1x
Washer M8-16
- 
1x
Washer M8-24







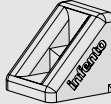
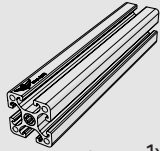

34

ride **BULLDOG**

- 
 Positioning block 2x
- 
 Locknut M8 1x
- 
 Bolt M8x25 (low head) 1x
- 
 Bearing block 40x40_Hexa 19 1x
- 
 L-joint 1x
- 
 Profile 11.02inch | 280mm 1x

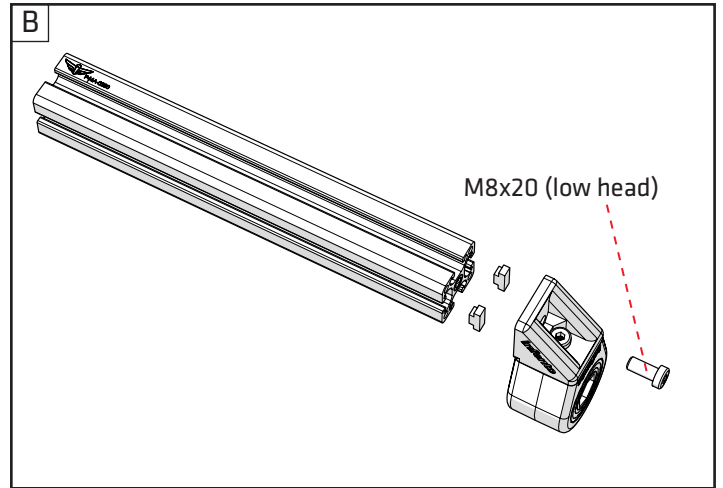
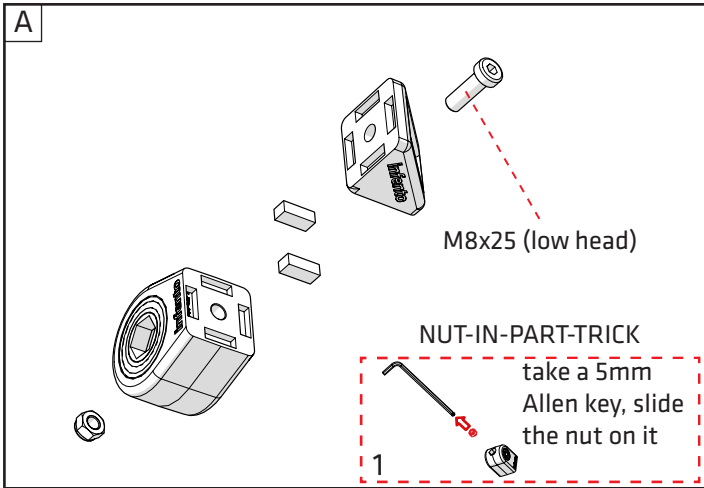
- 
 T-Positioning block 2x
- 
 Bolt M8x20 (low head) 1x



 Most nuts that you use for Infento are self-locking. This means that they cannot vibrate loose. On the inside of the bolt you will see a plastic washer that ensures it cannot turn freely, even if there is no tension on the bolt.

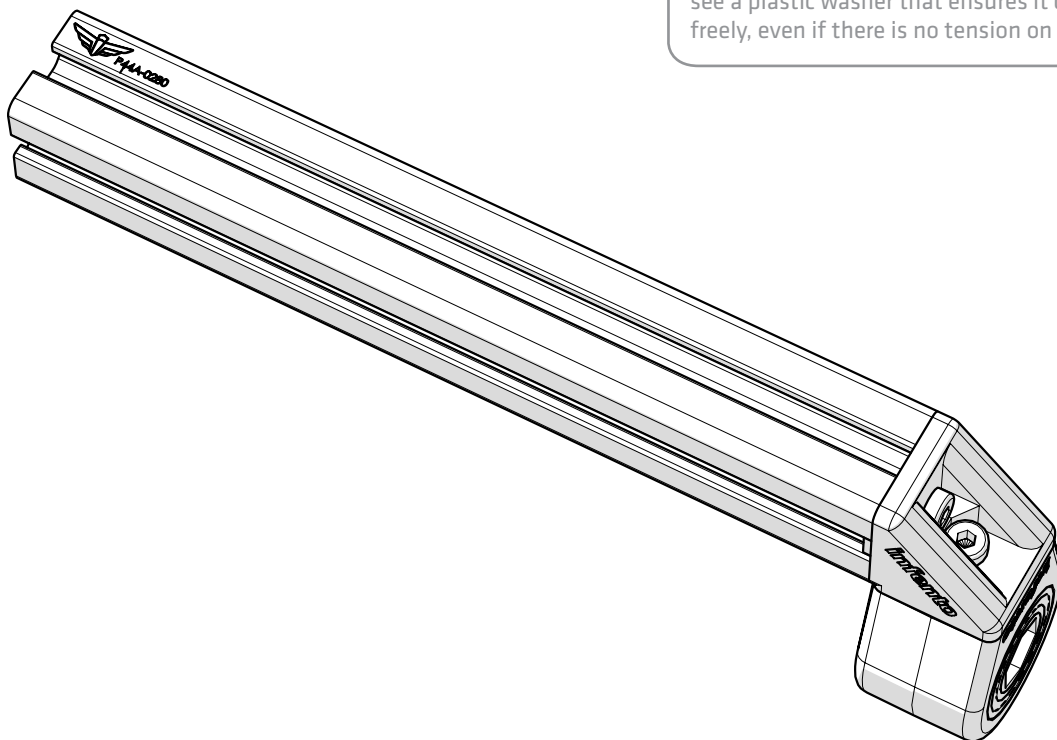



35

ride **BULLDOG**

- Bolt M8x20 1x
- Bolt M8x20 (low head) 1x
- T-Positioning block 4x
- L-joint 1x
- Multi angle joint 1x
- Profile 5.51inch | 140mm 1x

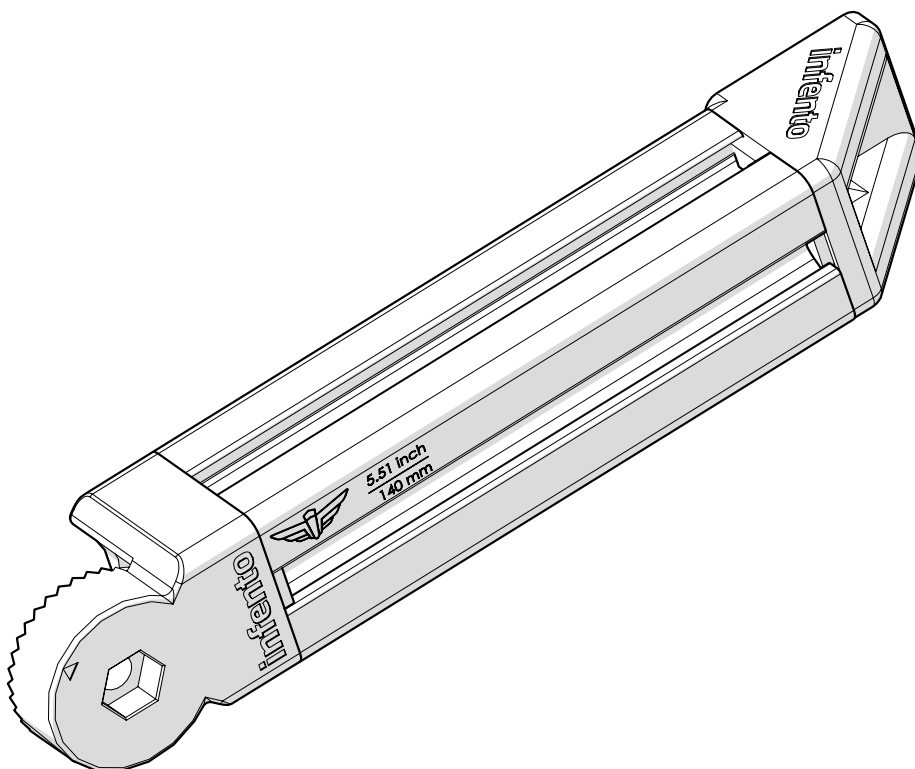
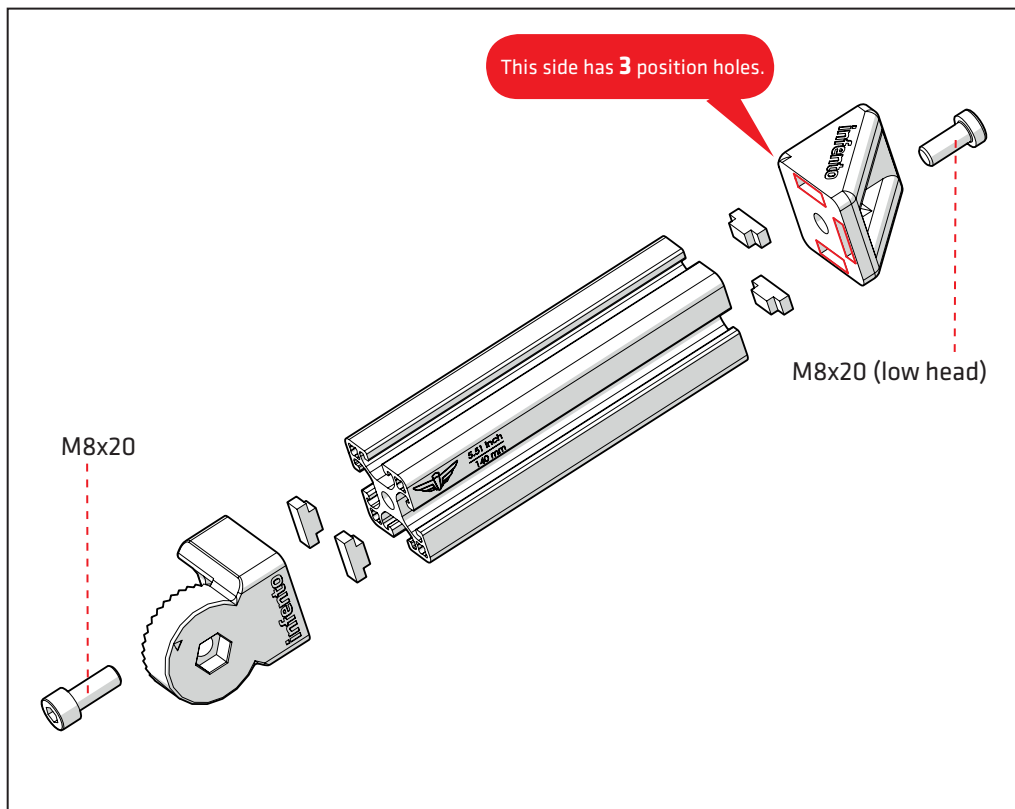



36

ride **BULLDOG**



Bolt M8x20
(low head) 1x



T-Positioning block 2x



Profile nut short 1x

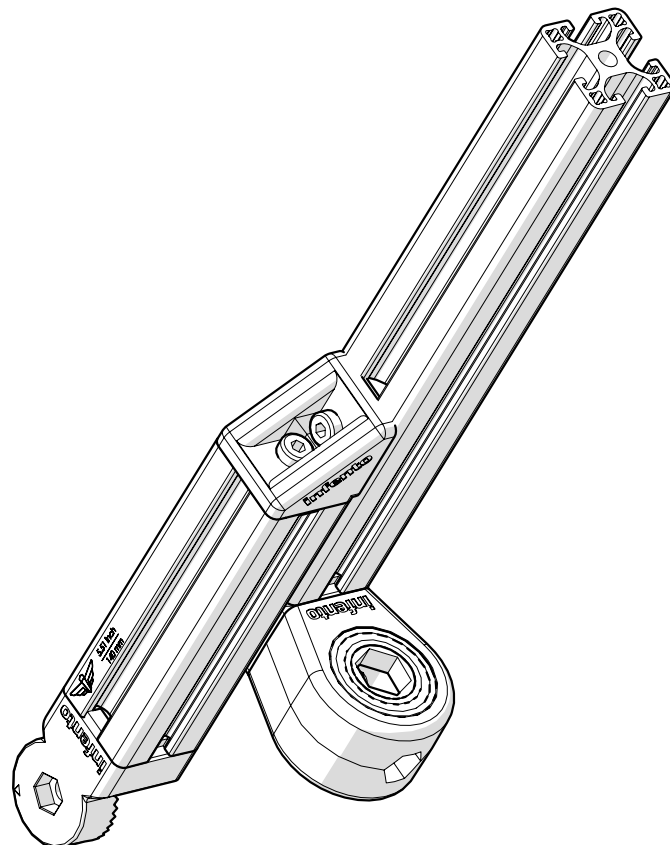
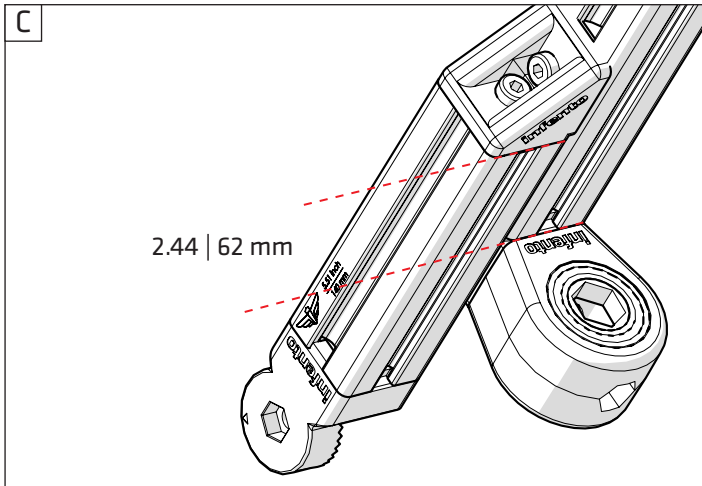
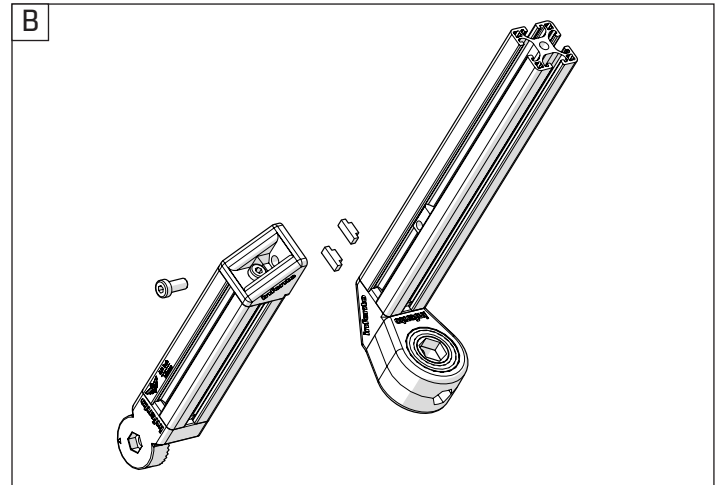
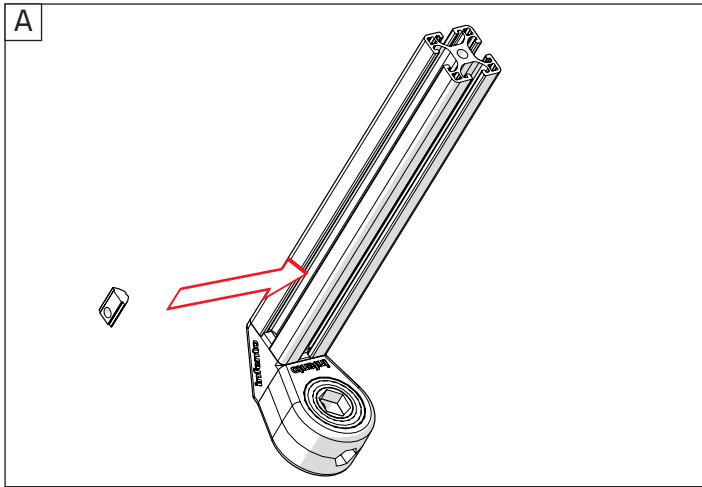



37

ride BULLDOG

- Bolt M8x20 1x
- Bolt M8x20 (low head) 1x
- T-Positioning block 4x
- L-joint 1x
- Multi angle joint 1x
- Profile 5.51inch | 140mm 1x

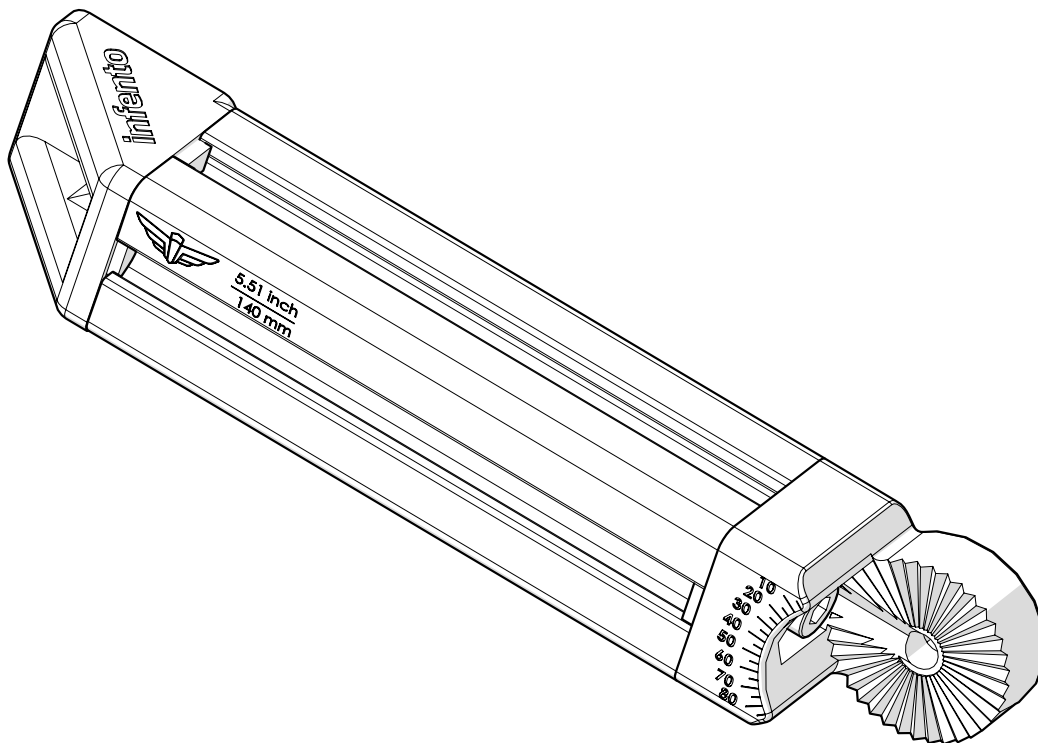
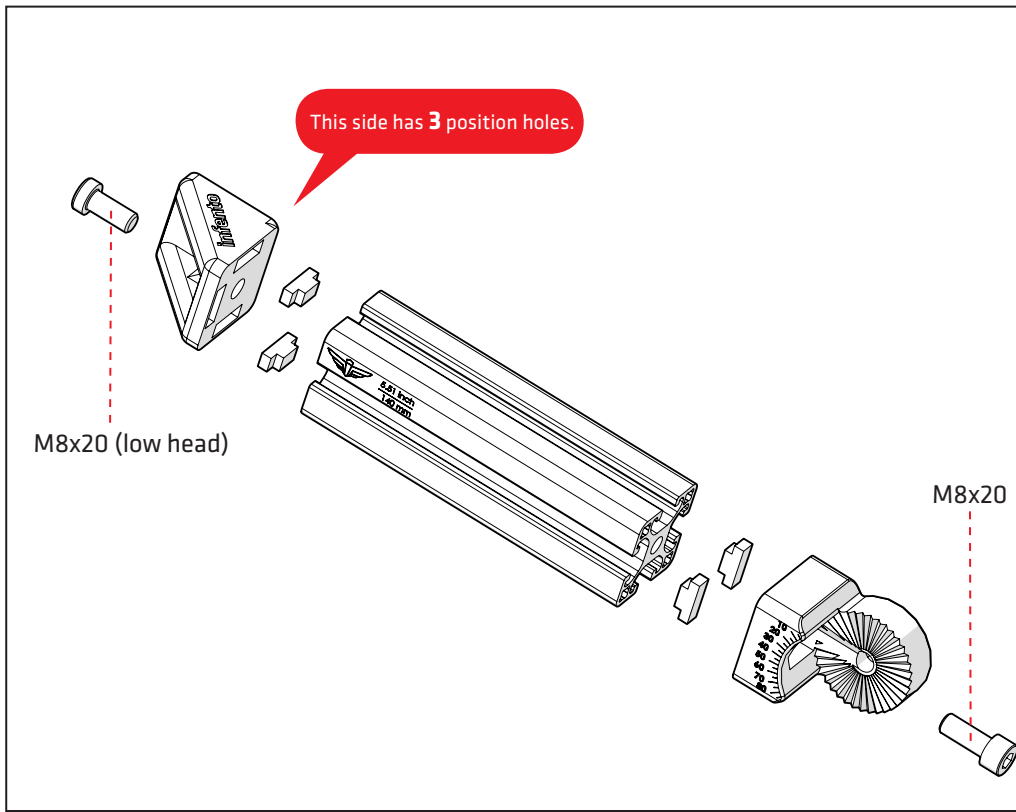



38

ride **BULLDOG**



Bolt M8x20
(low head) 1x



2x



Profile nut short 1x

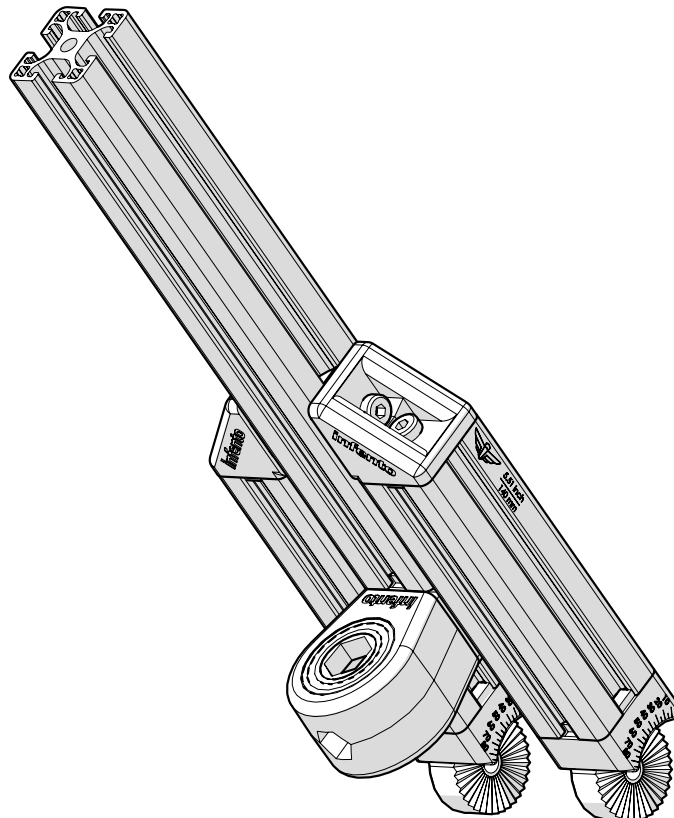
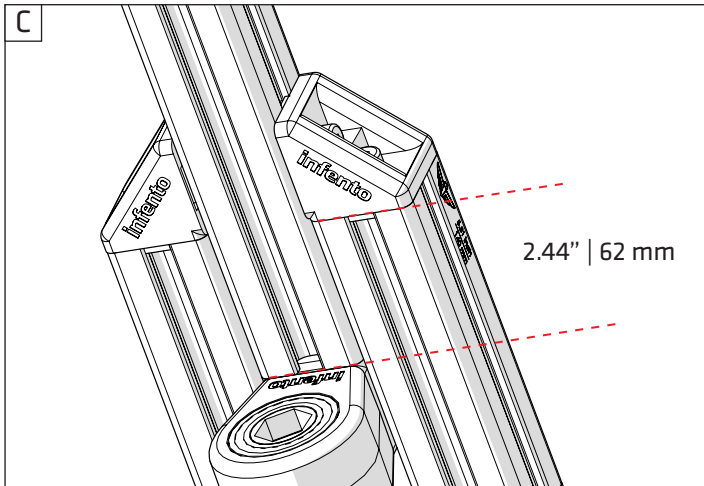
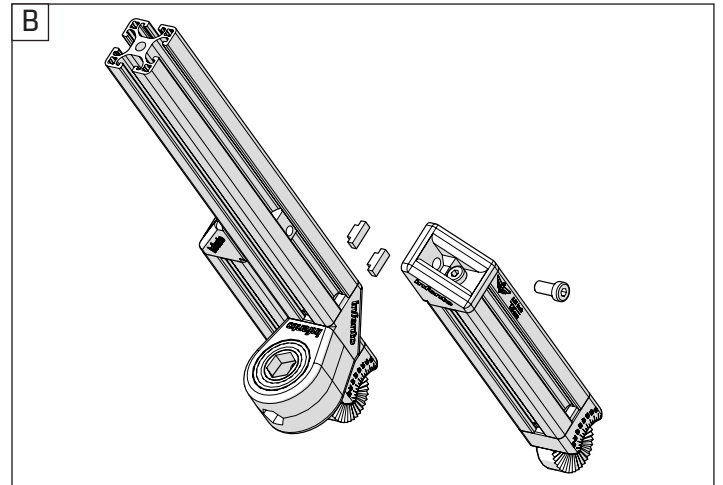
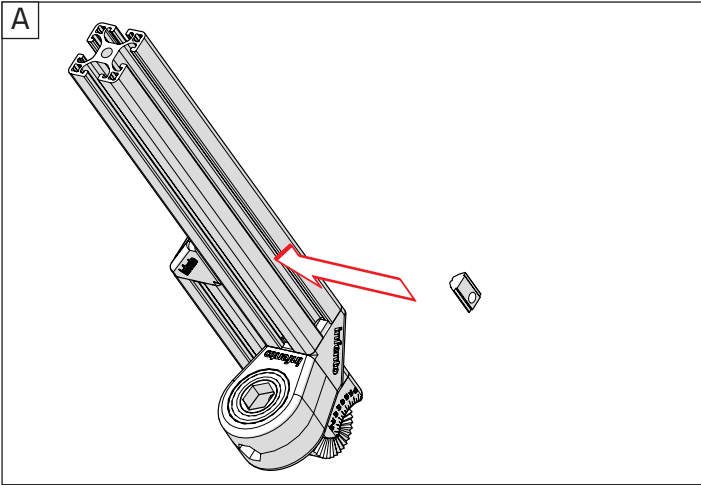



39

ride **BULLDOG**



Locknut M8 1x



Bolt M8x25 (low head) 1x



Positioning block 2x



L-joint 1x

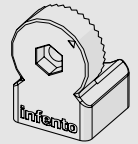

Multi angle joint 1x

A

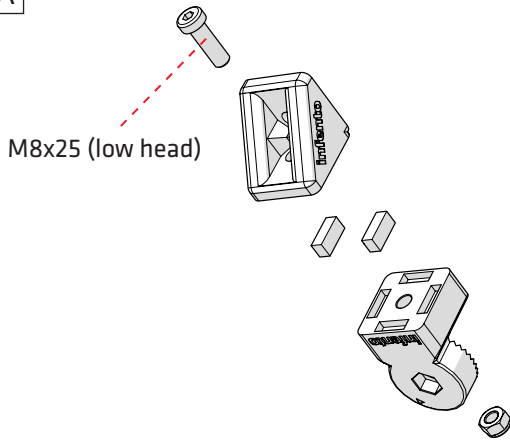

C

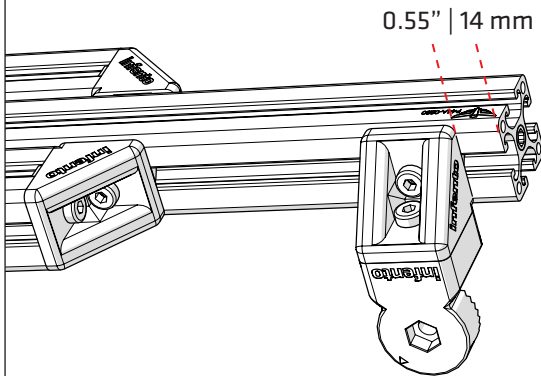

B

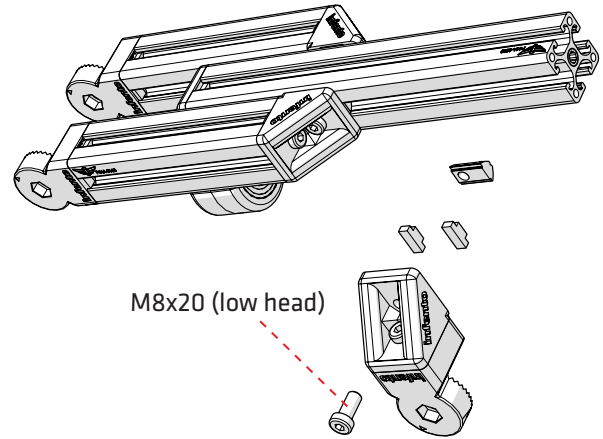

T-Positioning block 2x



Profile nut short 1x



Bolt M8x20 (low head) 1x

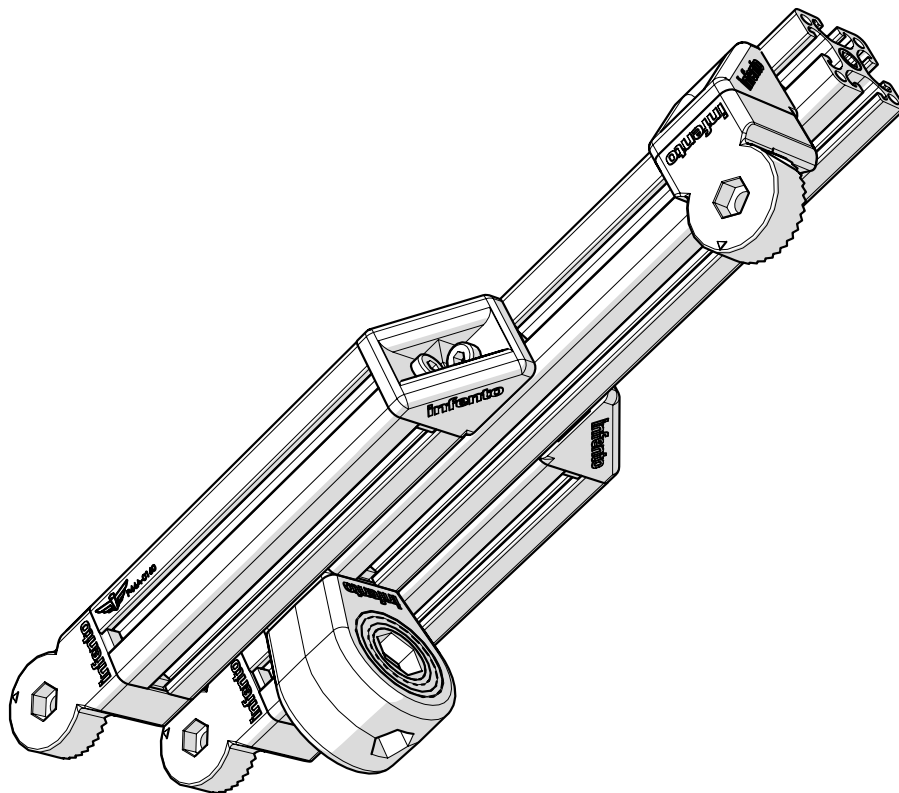



40

ride **BULLDOG**

- Locknut M8 1x
- Bolt M8x25 (low head) 1x
- Positioning block 2x
- L-joint 1x
- Multi angle joint 1x

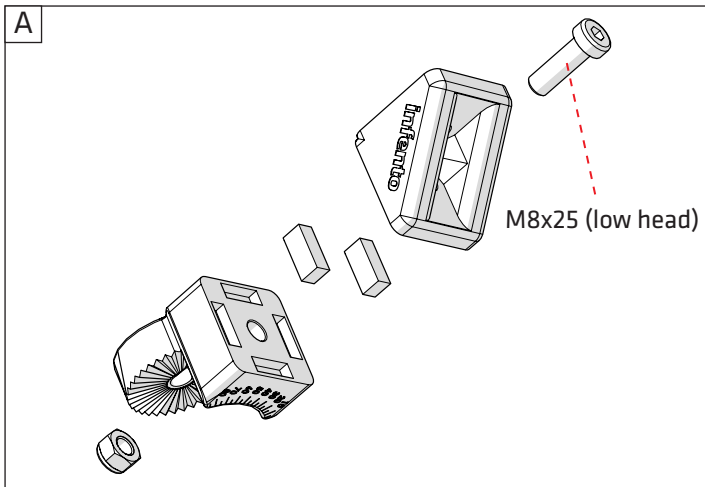

- T-Positioning block 2x
- Profile nut short 1x
- Bolt M8x20 (low head) 1x

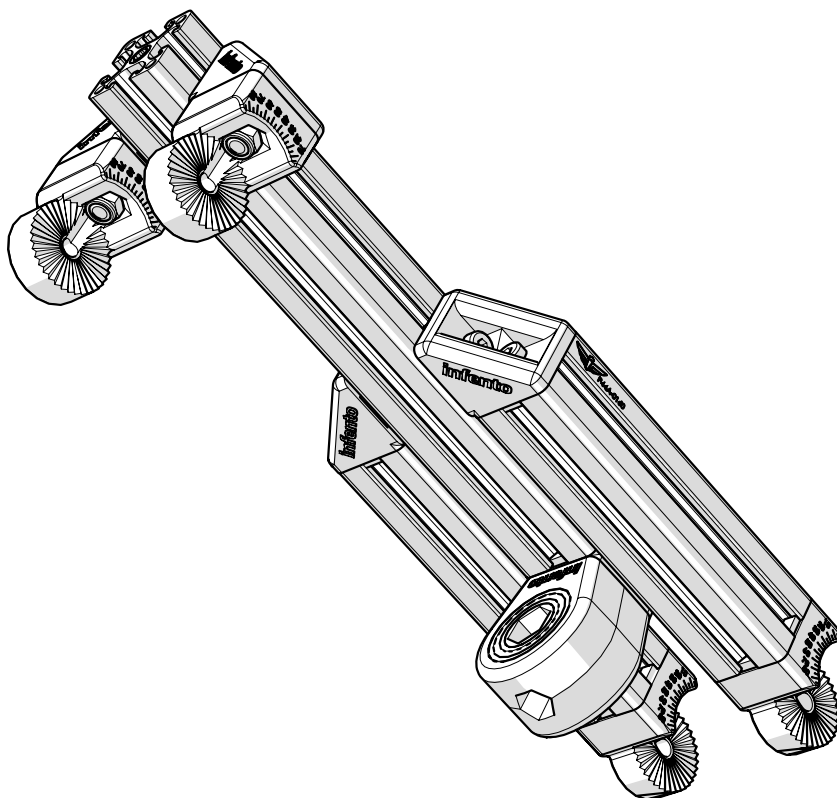
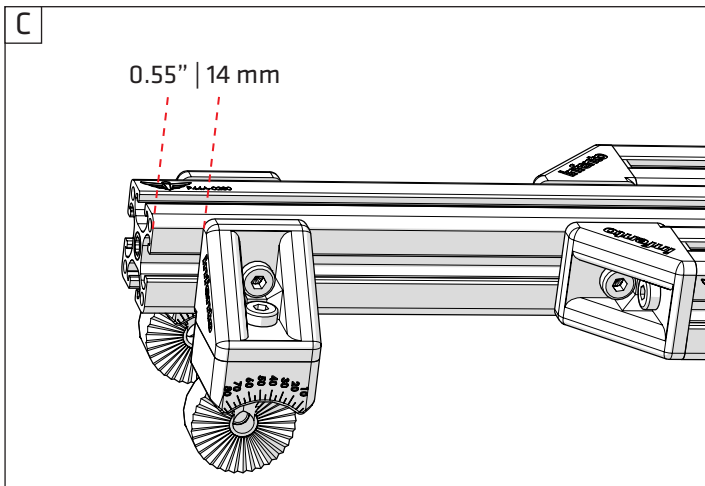
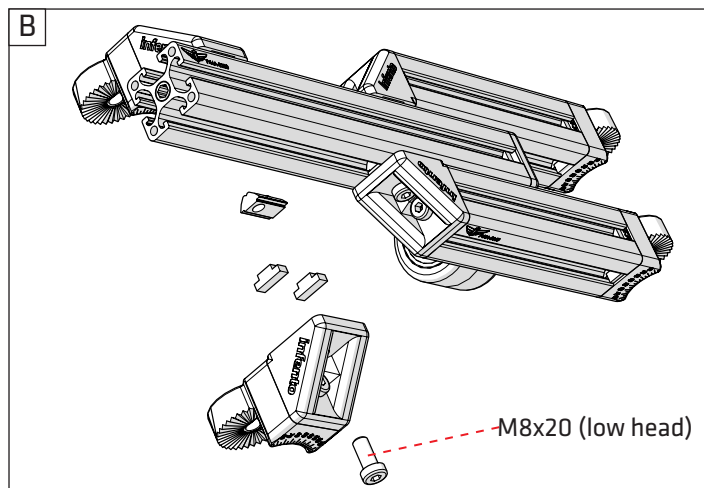



41

ride **BULLDOG**

 + 2x
Locknut M8

 + 1x
Bolt M8x25
(low head)

 + 2x
Positioning block

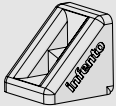
 + 1x
L-joint

 + 1x
Bearing block
40x40_Hexa 19

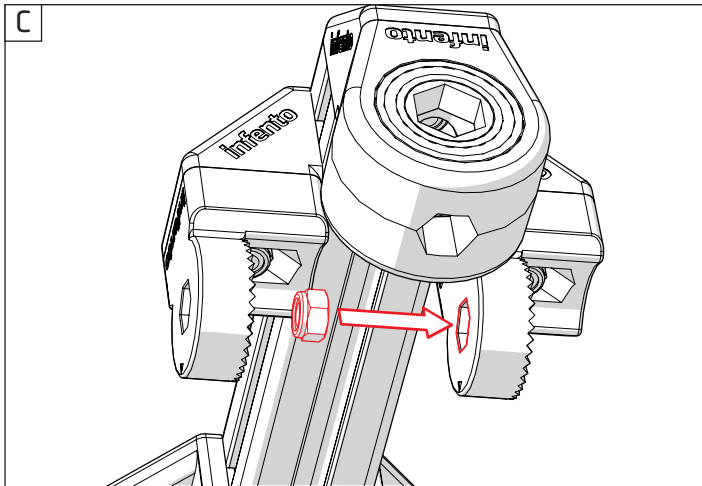
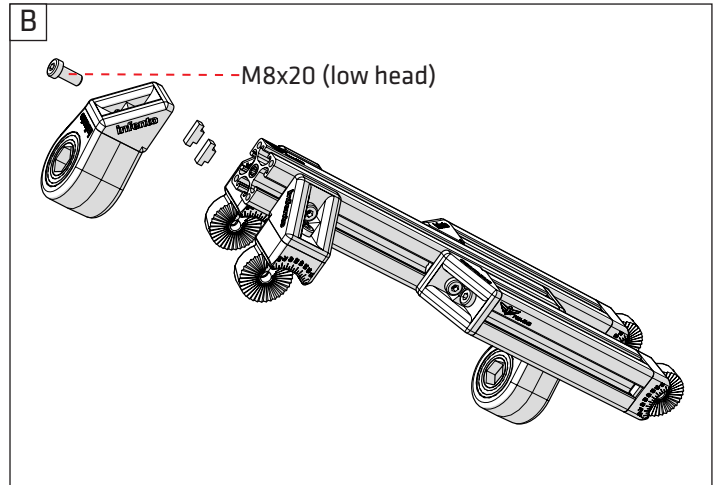
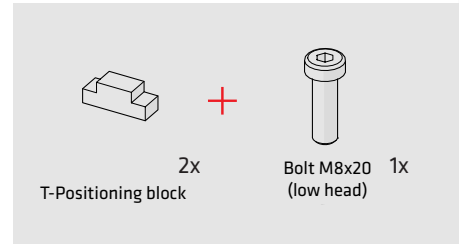
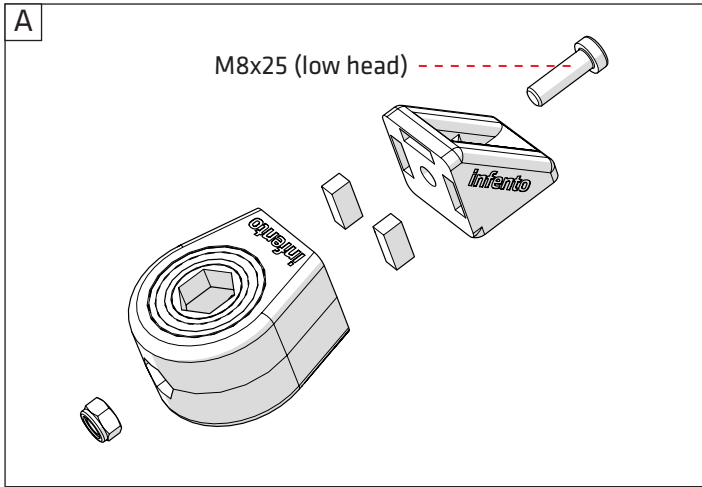

NUT-IN-PART-TRICK

- 

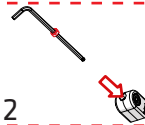
take a 5mm
Allen key, slide
the nut on it
- 

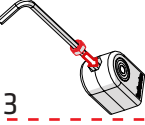
stick the Allen
key through
the part
- 



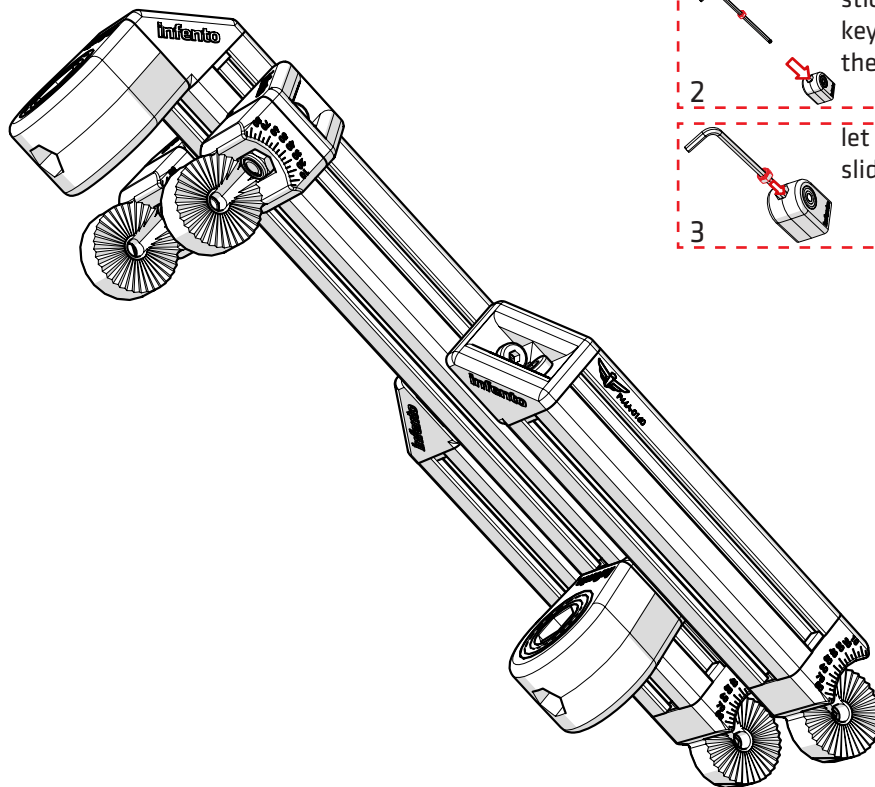



let the nut
slide down



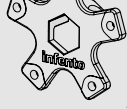

42

ride **BULLDOG**

-  2x Bolt M6x20
-  + 1x Clamping part holes with M6 thread
-  4x Bolt M6x8
-  + 1x Steering plate
-  + 1x Axle flange
-  1x Axle 21.65inch | 550mm

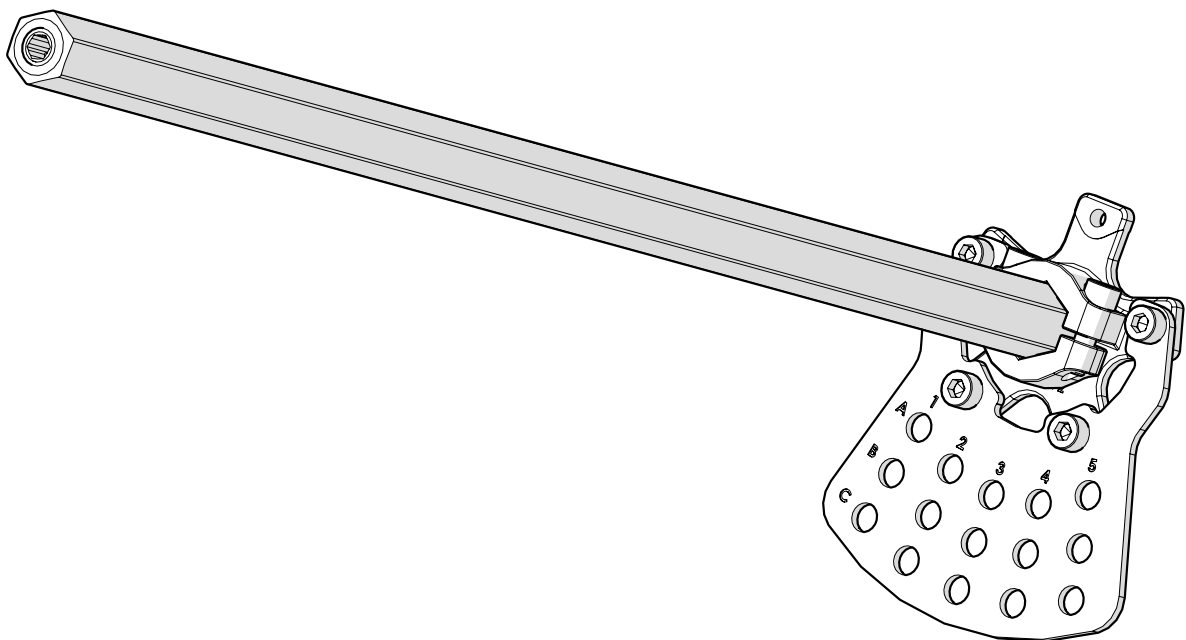
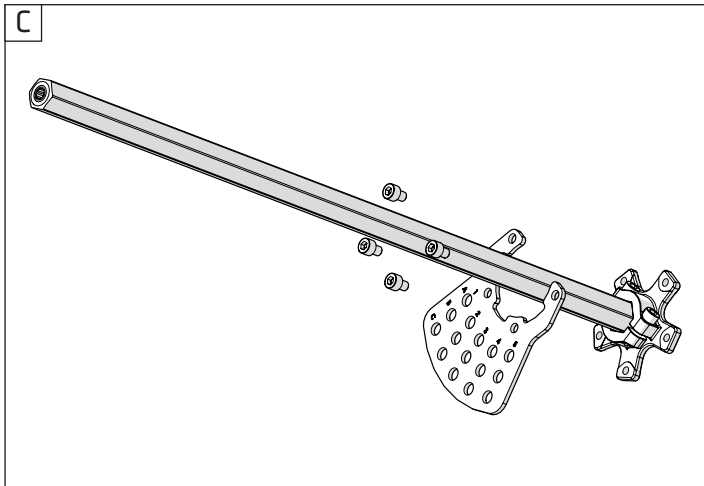
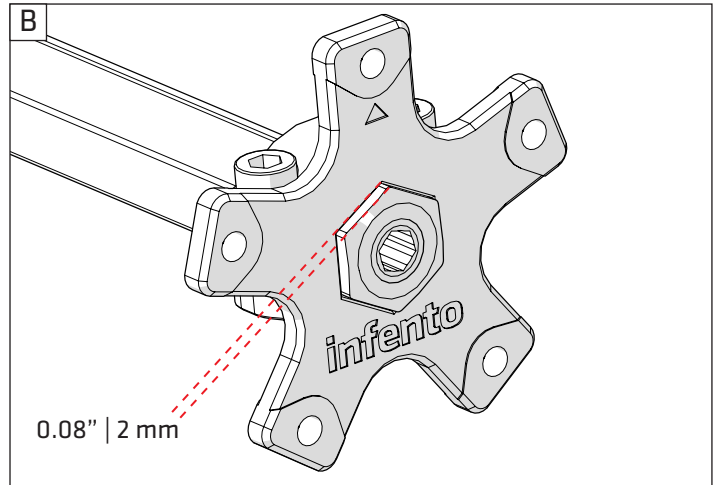
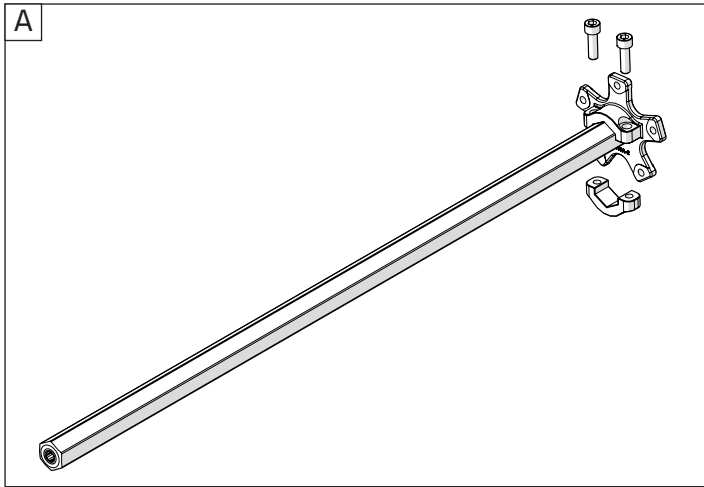



43

ride *BULLDOG*

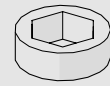

Spacer 4x
0.39inch | 10mm

+

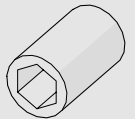

Spacer 1x
1.97inch | 50mm

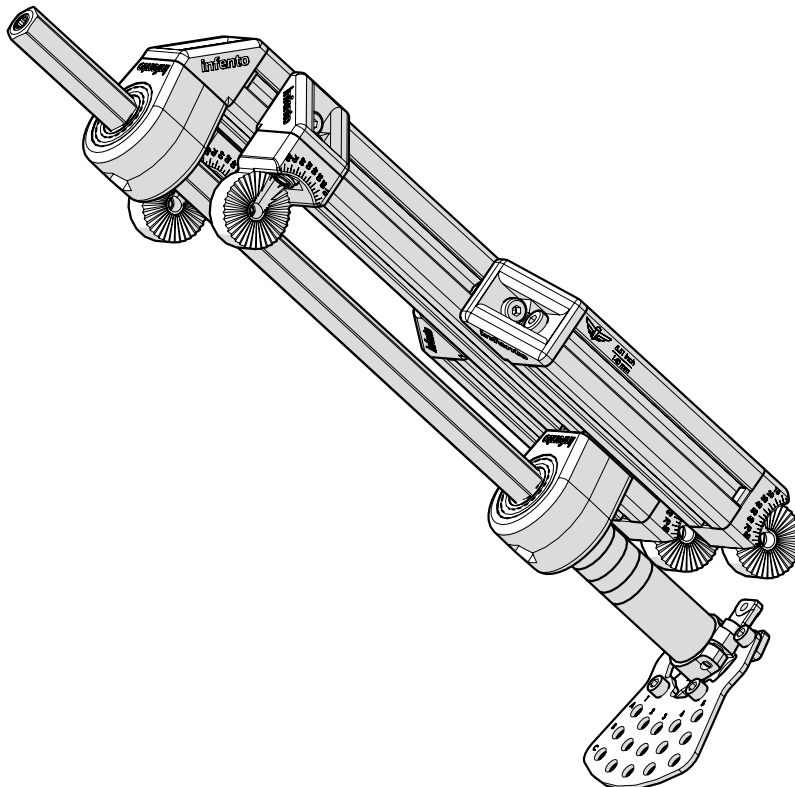
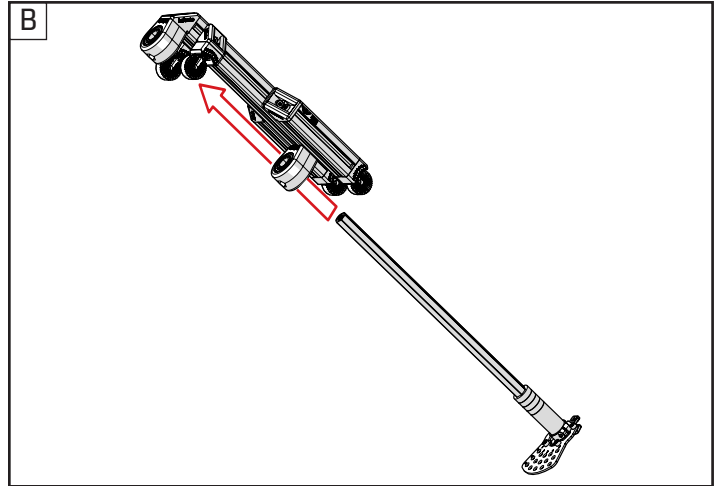
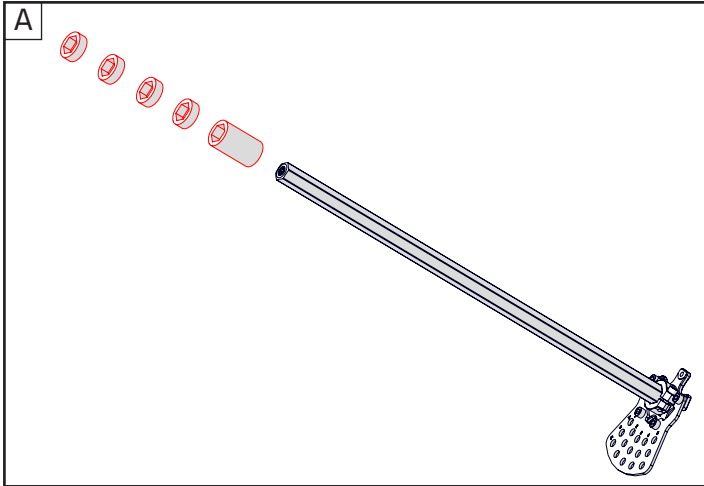



44

ride **BULLDOG**



2x



2x

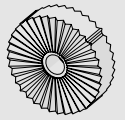

2x

Bolt M8x35

Locknut M8



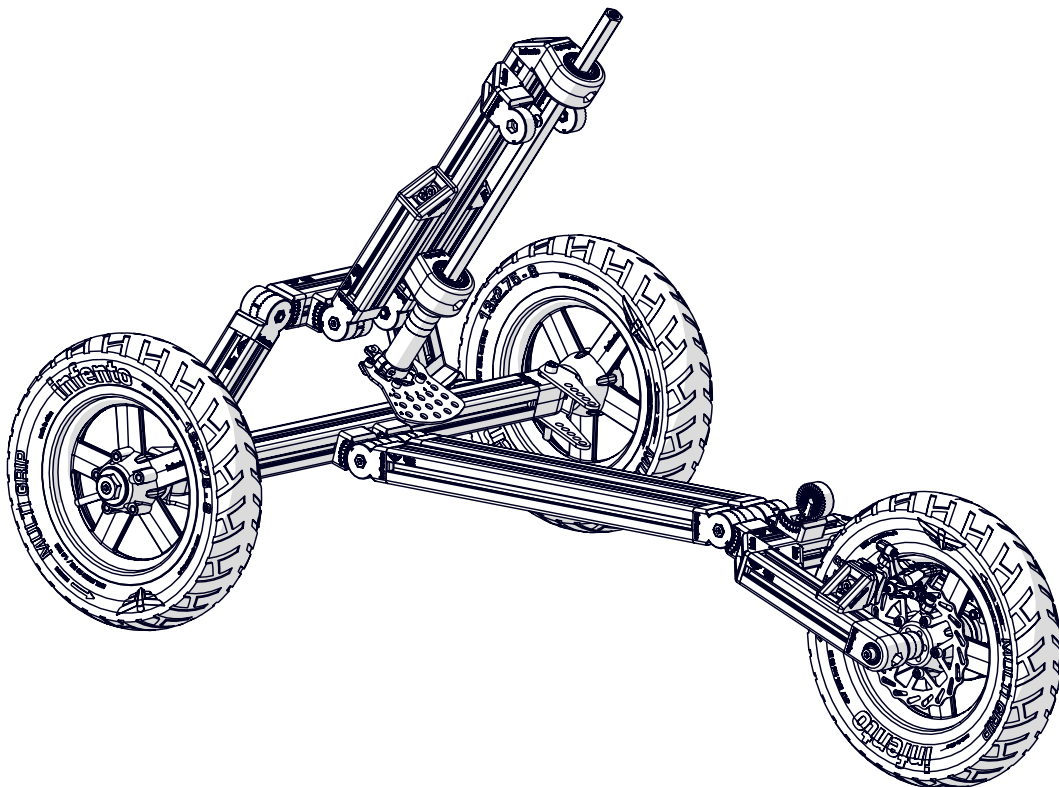
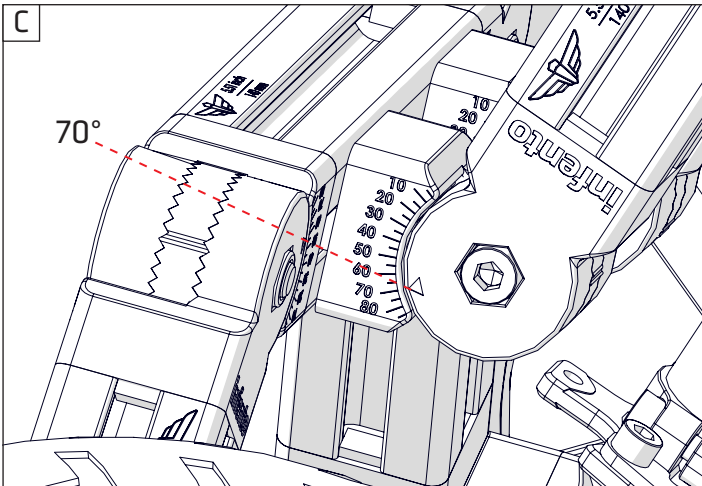
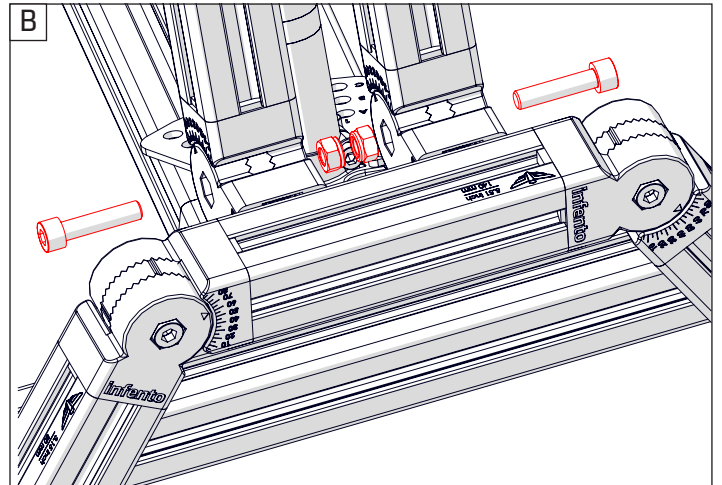
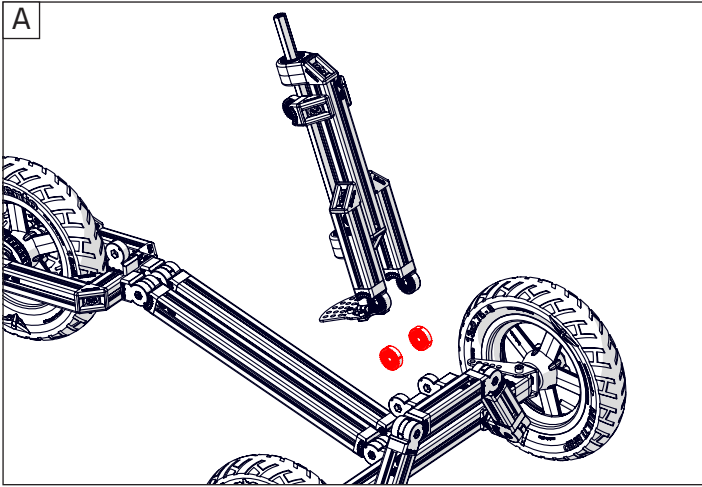

Knurled disc 2 stripes





45

ride **BULLDOG**

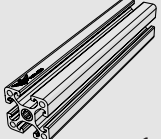
-  2x
-  2x
-  4x
-  2x
-  1x

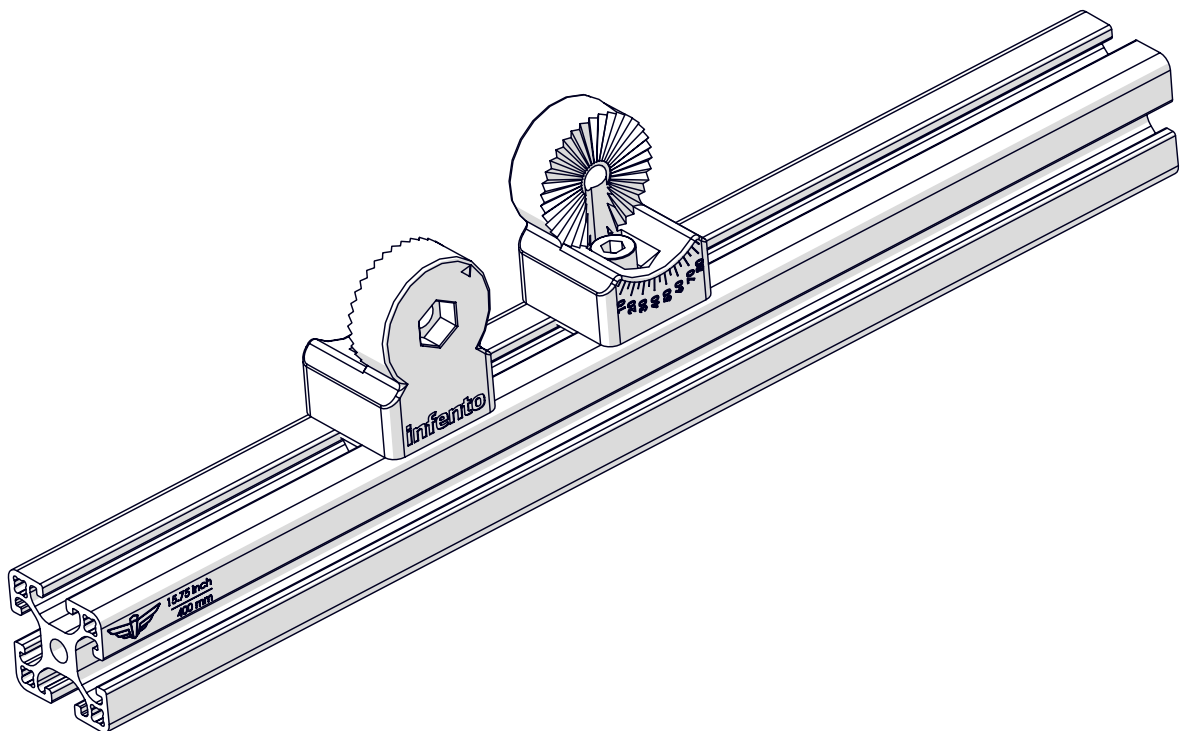
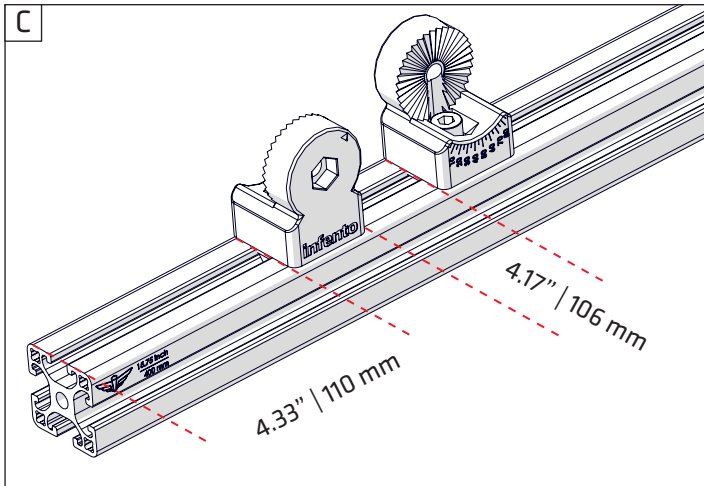
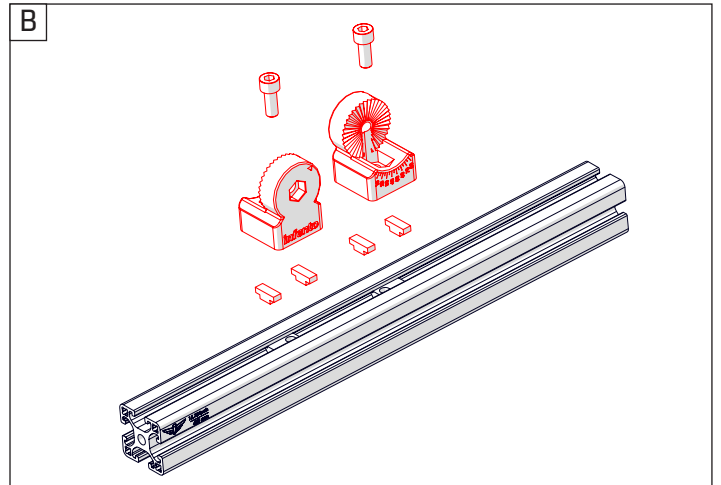
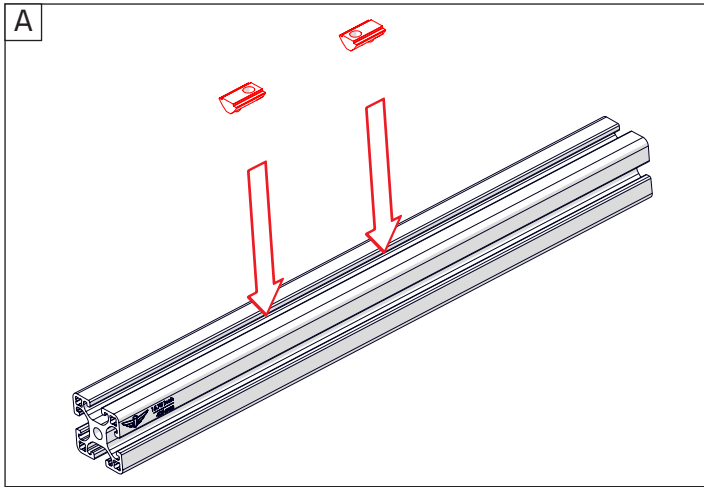



46

ride **BULLDOG**



Protect cap

1x



Bolt M8x20

1x



T-Positioning block

2x



Multi angle joint

1x

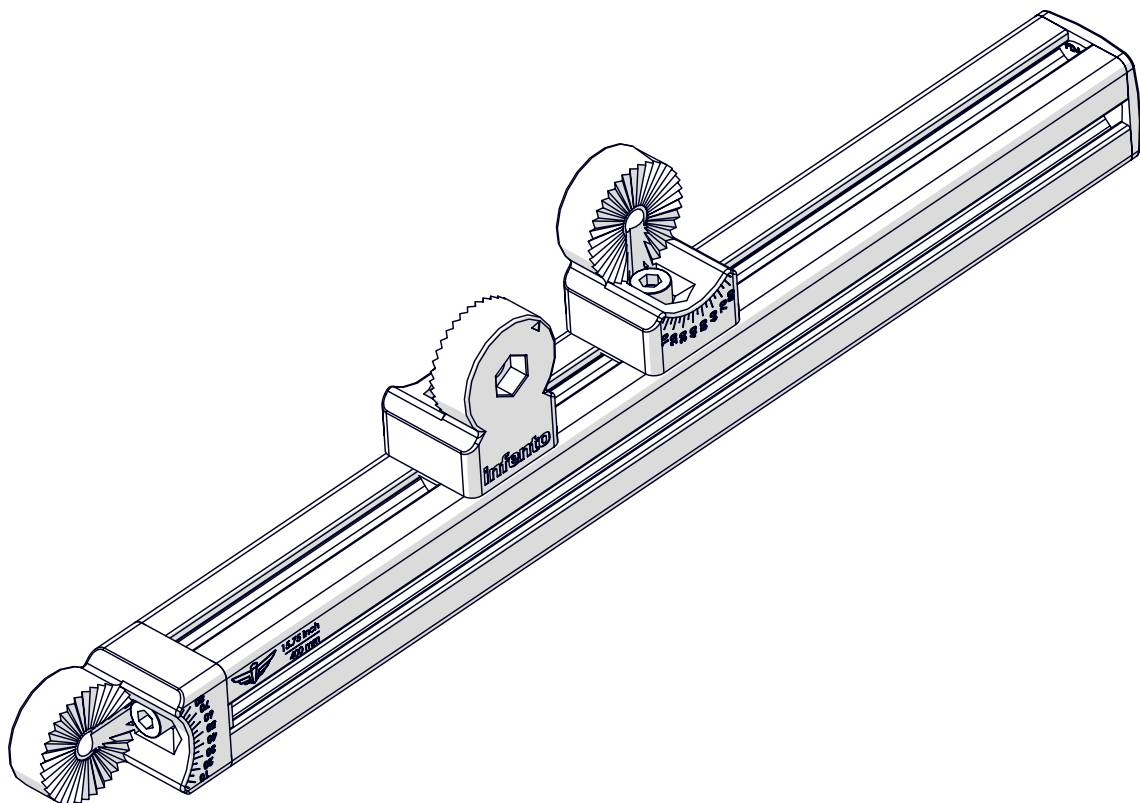
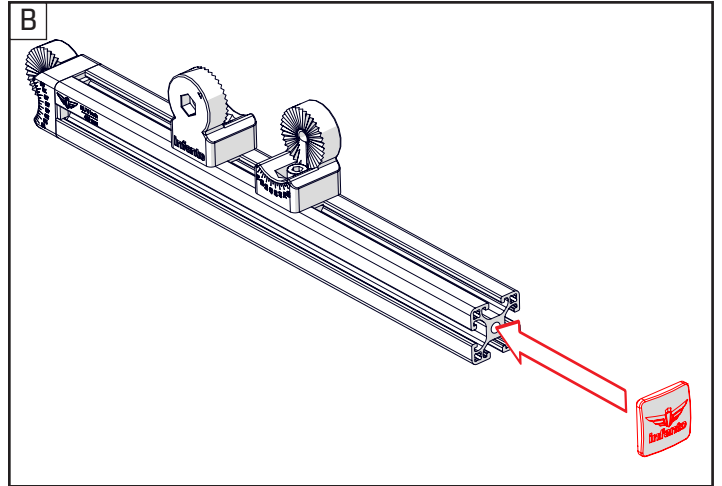
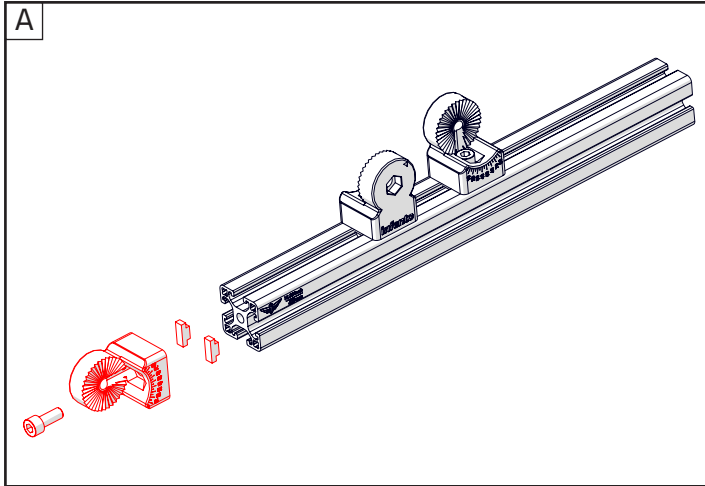



47

ride **BULLDOG**

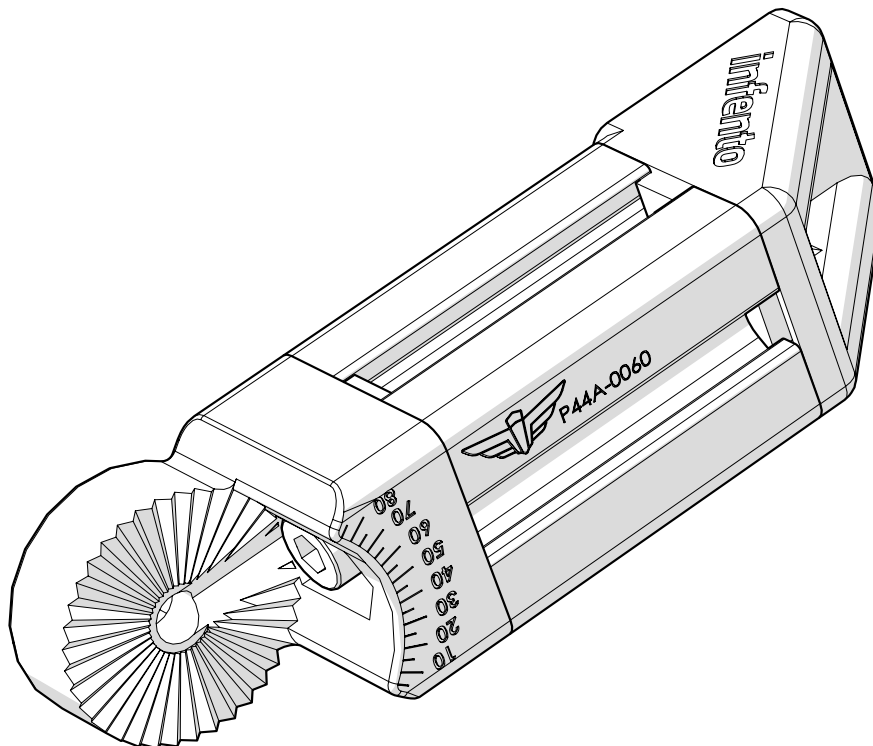
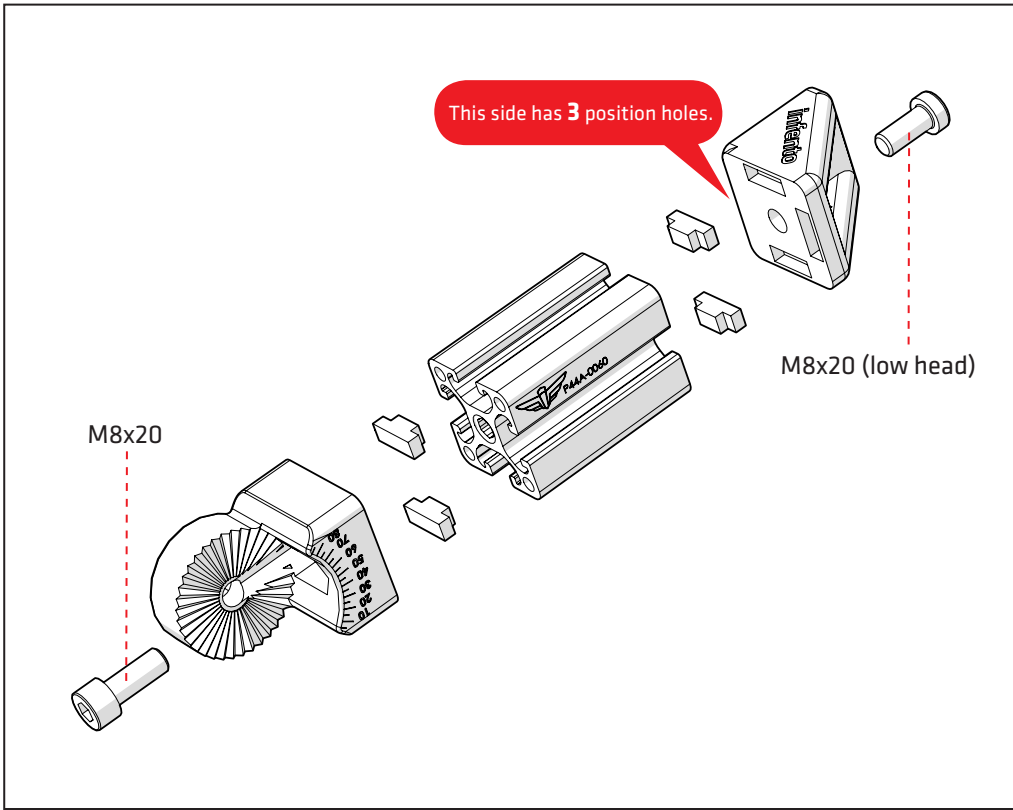

- Bolt M8x20 1x
- Bolt M8x20 (low head) 1x
- T-Positioning block 4x
- L-joint 1x
- Multi angle joint 1x
- Profile 2.36inch | 60mm 1x





48

ride **BULLDOG**

-  1x
-  2x
-  1x

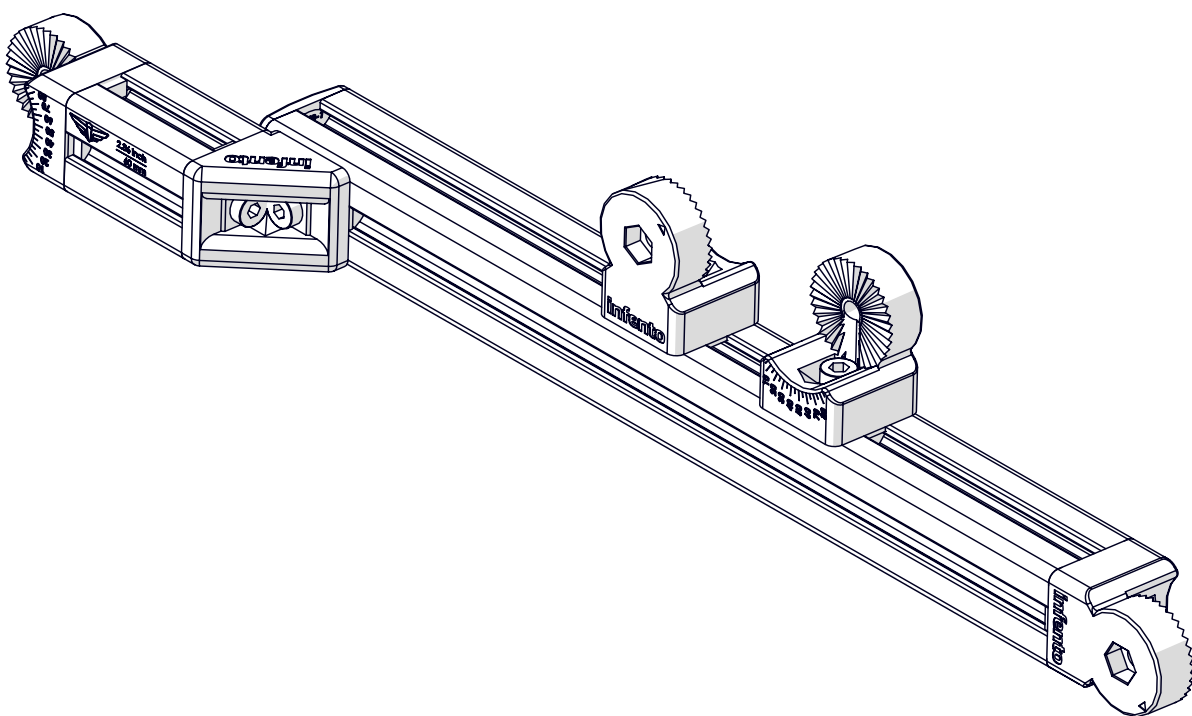
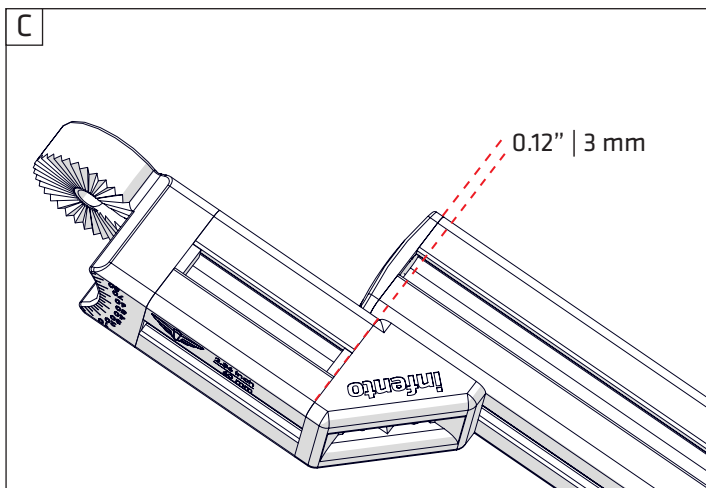
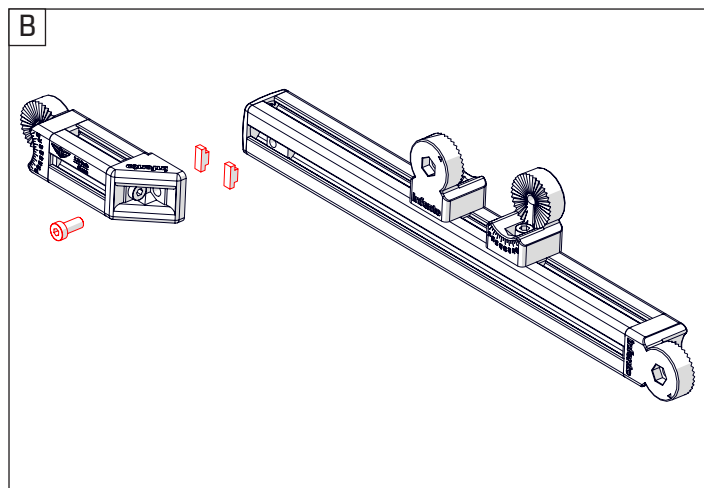
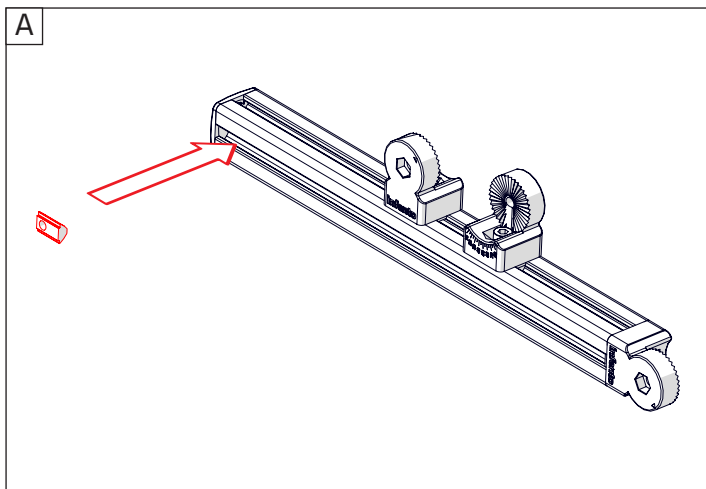



49

ride **BULLDOG**

- Bolt M8x20 1x
- Bolt M8x20 (low head) 1x
- T-Positioning block 4x
- L-joint 1x
- Multi angle joint 1x
- Profile 2.36inch | 60mm 1x

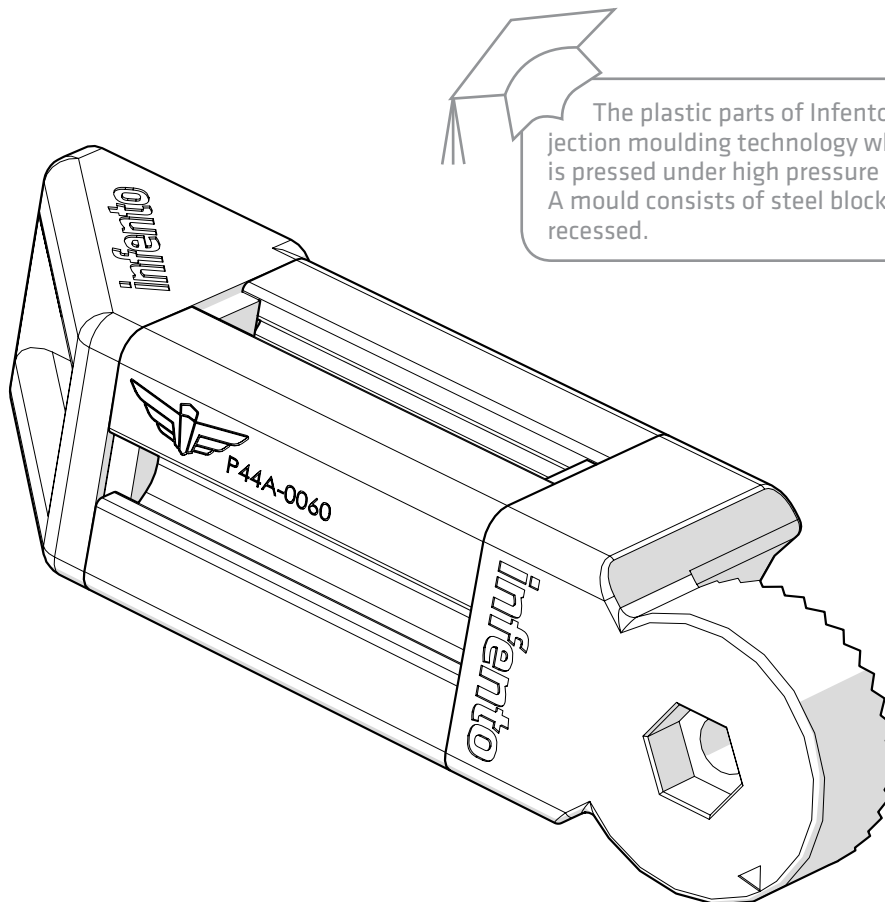
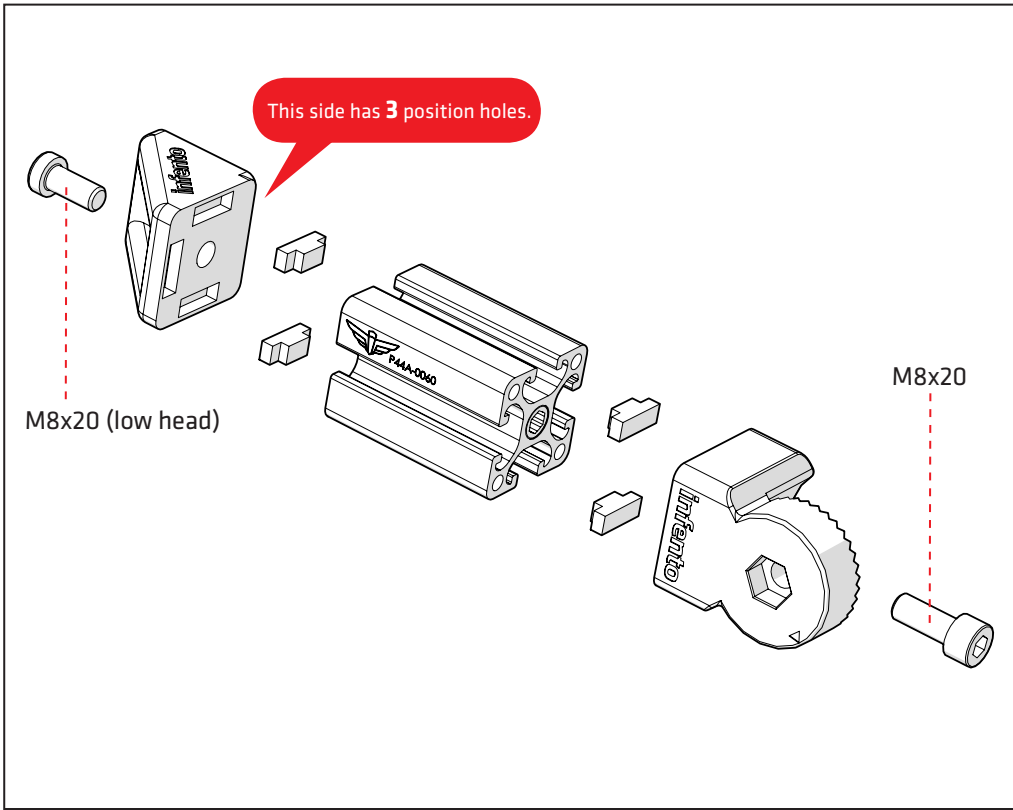



The plastic parts of Infento are made using injection moulding technology where molten plastic is pressed under high pressure into a mould. A mould consists of steel blocks in which a shape is recessed.



50

ride **BULLDOG**

-  1x
-  2x
-  1x

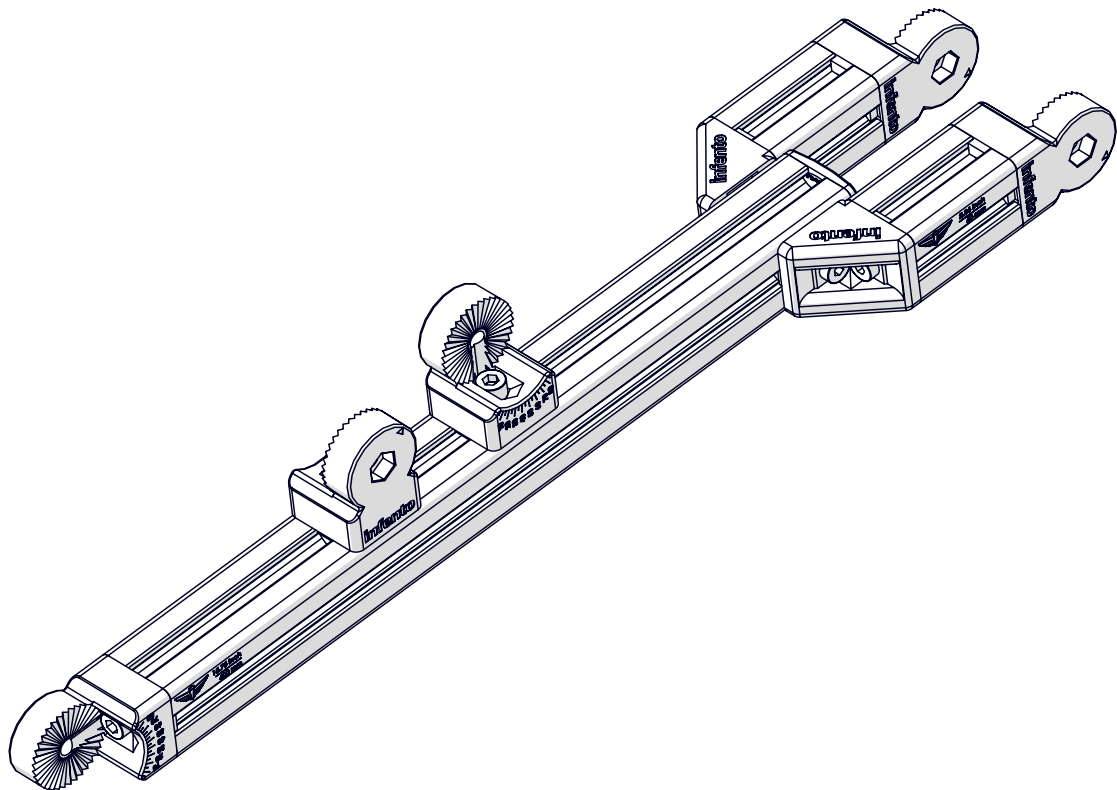
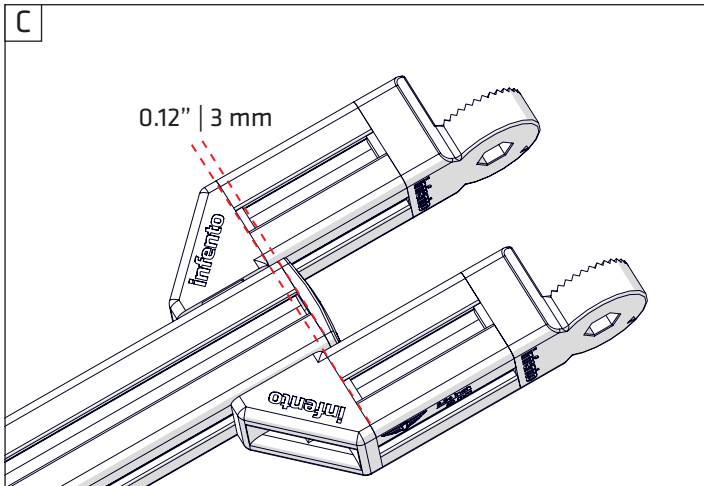
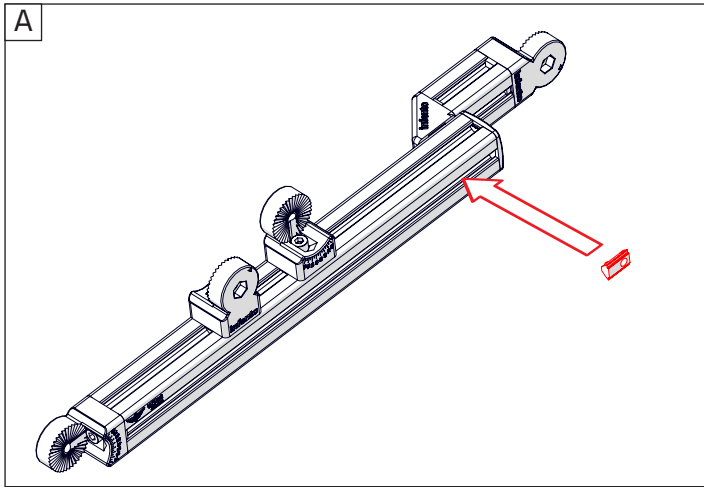



51

ride BULLDOG

- Bolt M8x35 3x + Locknut M8 2x + Knurled disc 2 stripes 2x + Knurled disc 1 stripe 1x

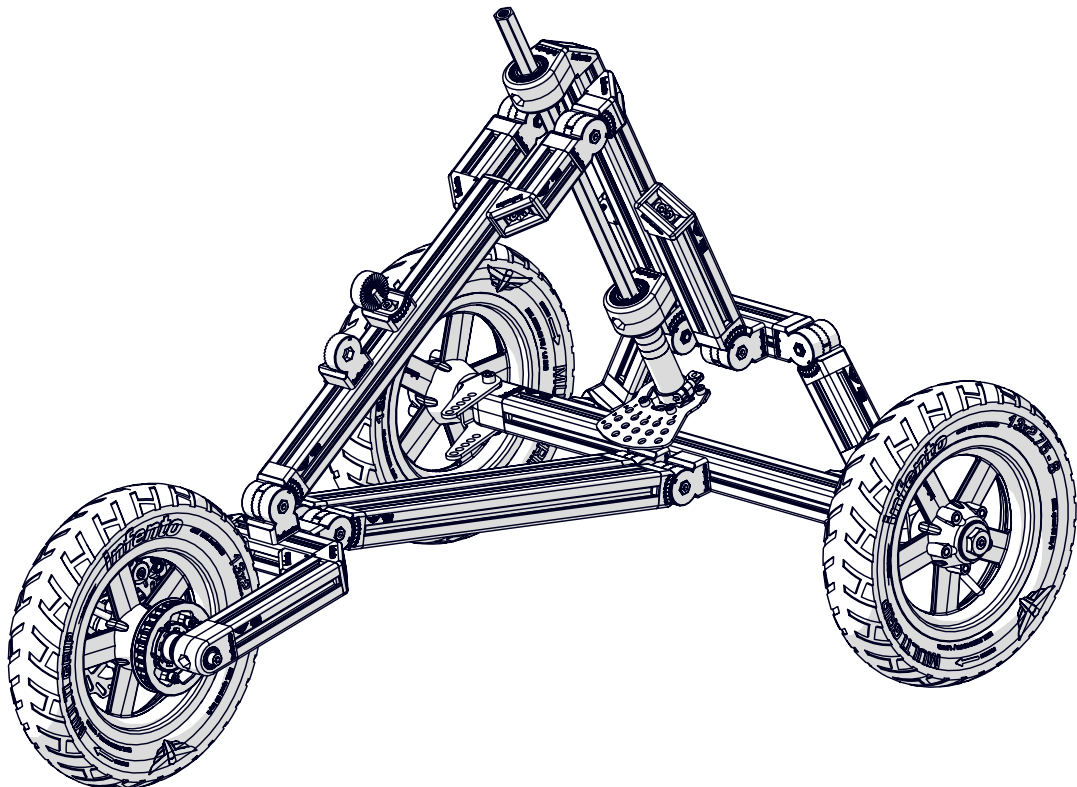
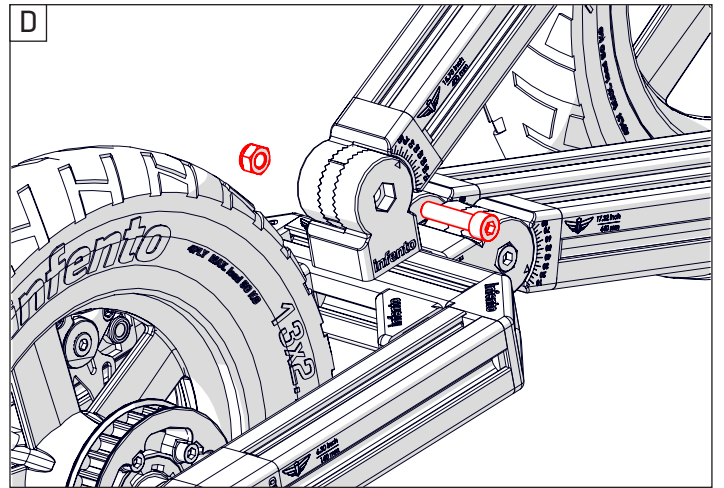
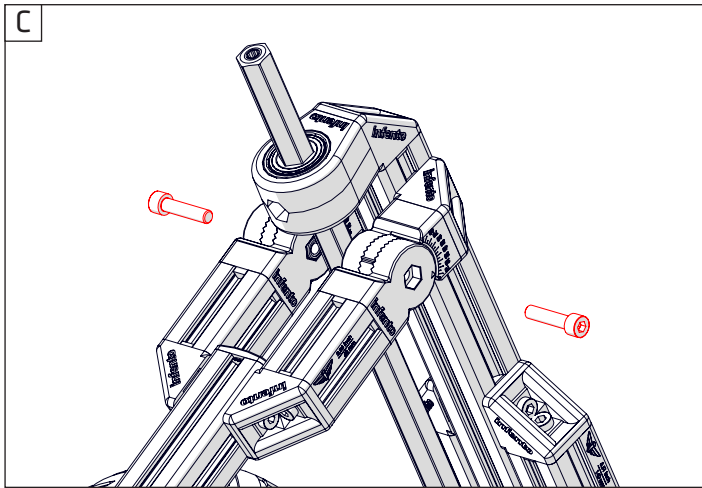
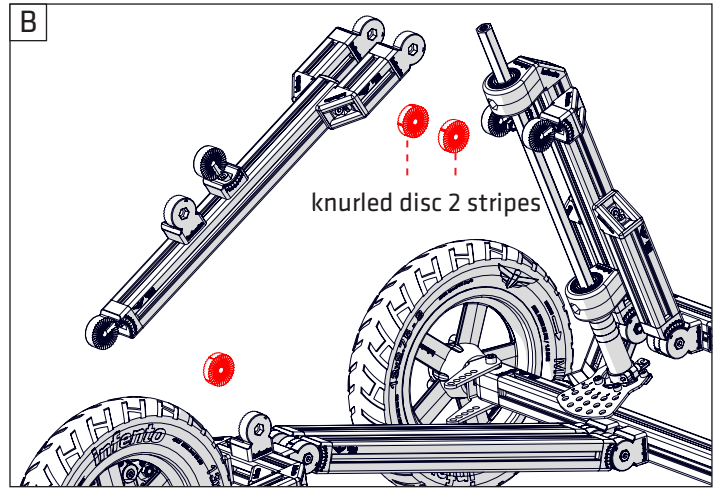
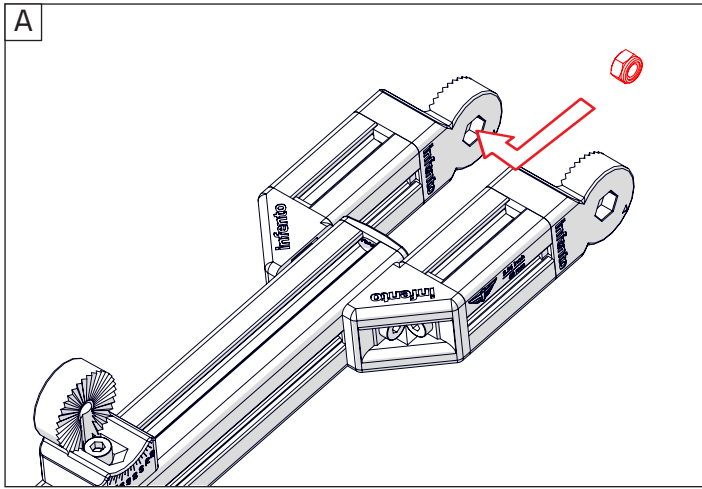



52

ride **BULLDOG**

- Rod end M8 internal thread 2x
- M8 Threaded rod 5.91inch | 150mm 2x
- Nut M8 6x
- Rod end M8 external thread 2x
- Steering turnbuckle 3.94in | 100mm 2x

A

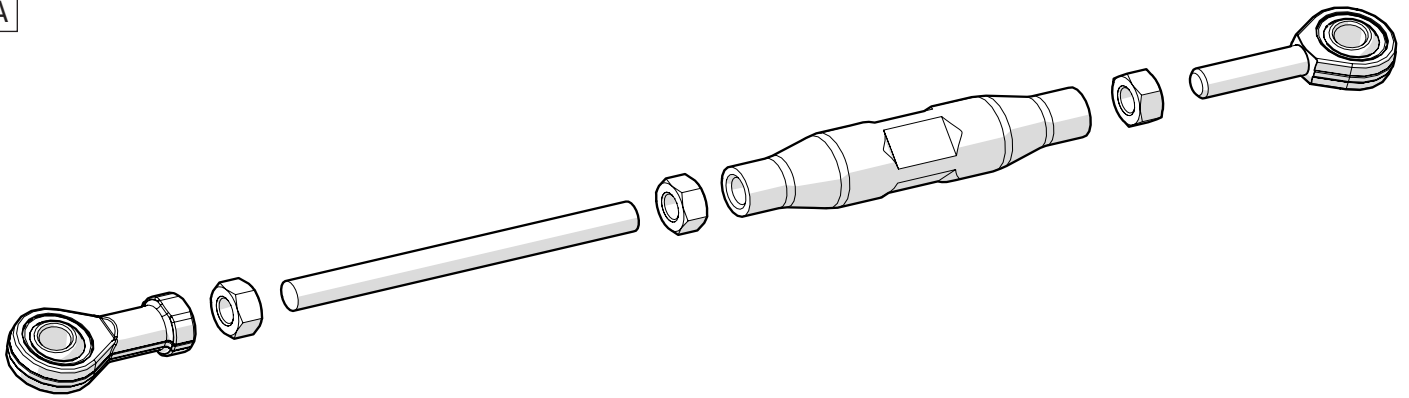

B

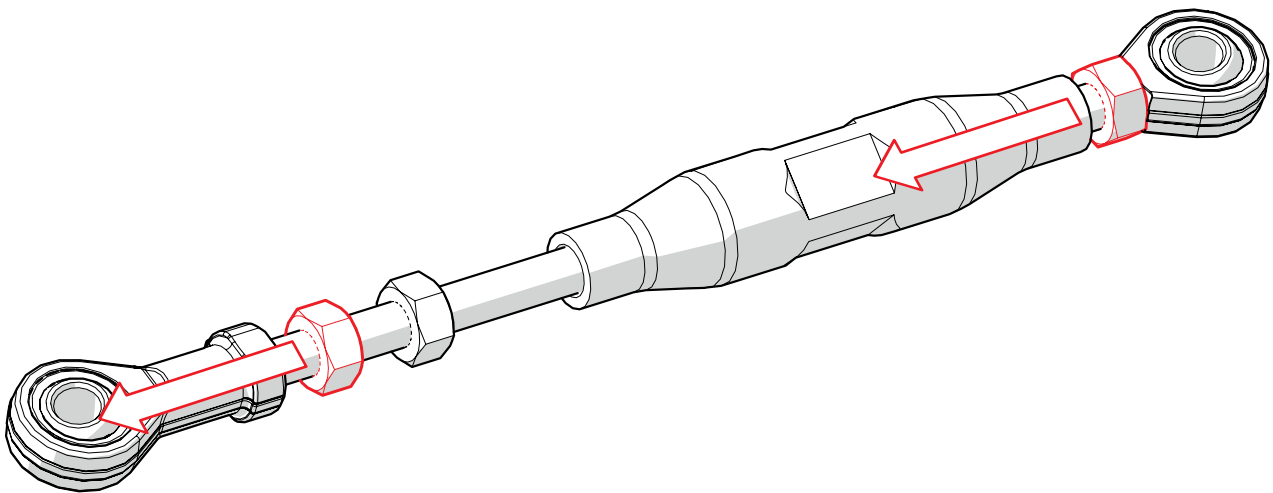

C

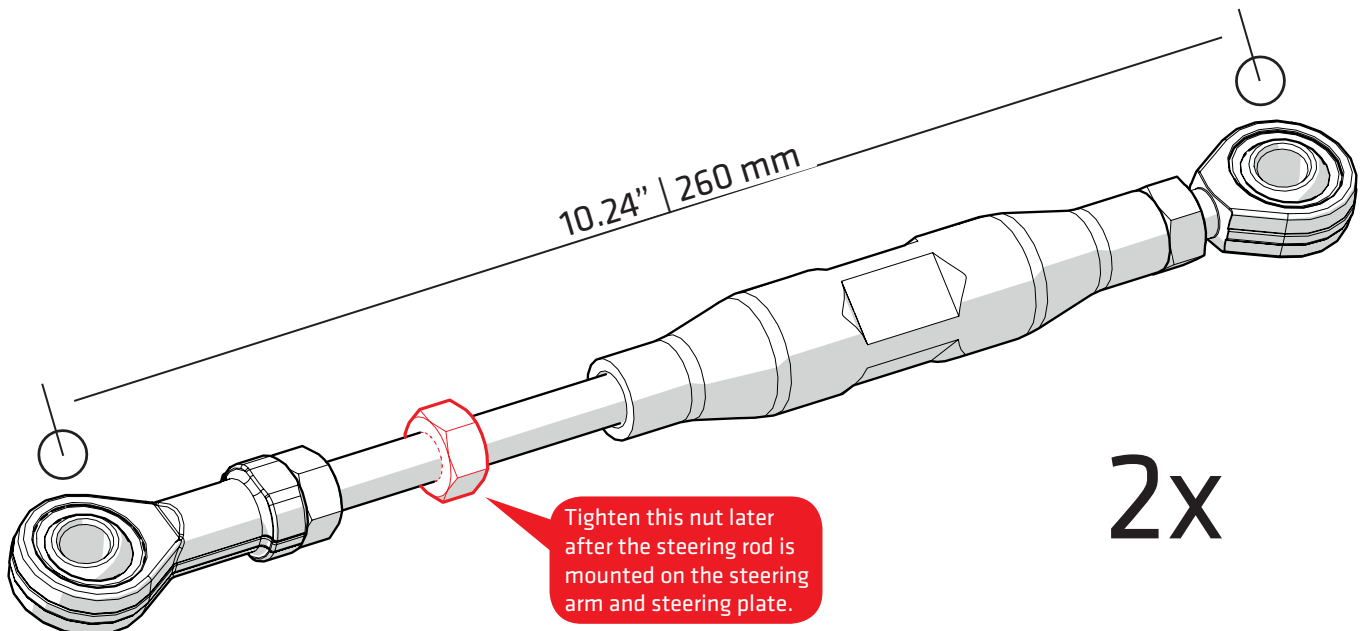



53

ride **BULLDOG**



Nut M8

8x



Conical spring
washer M8-13

8x



Bolt M8x45

4x

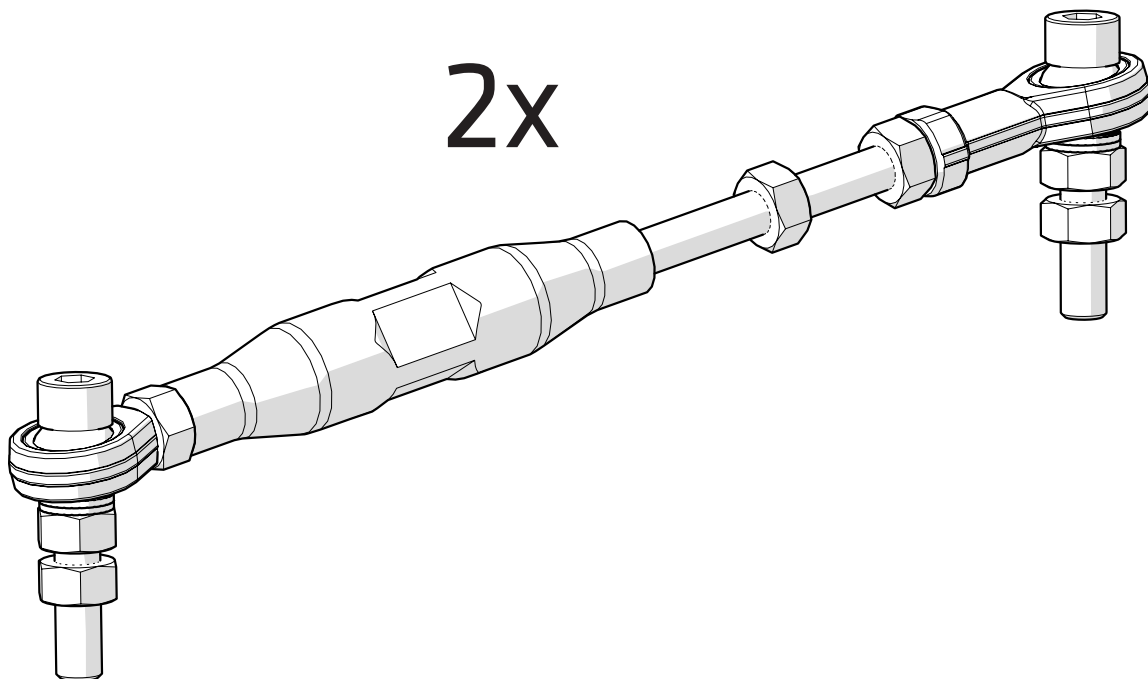
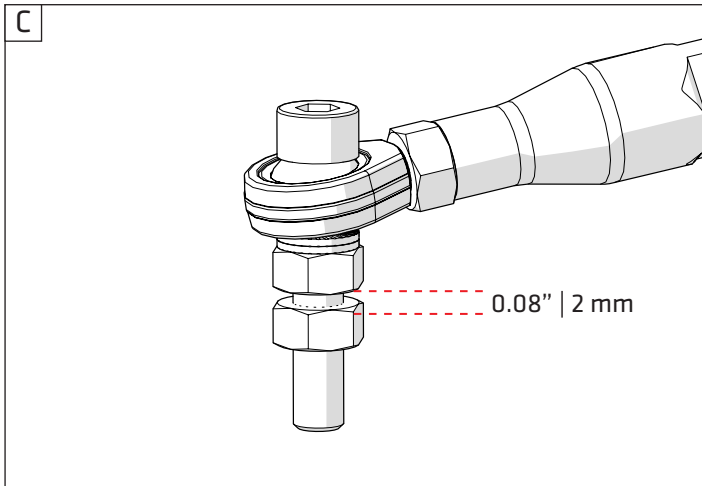
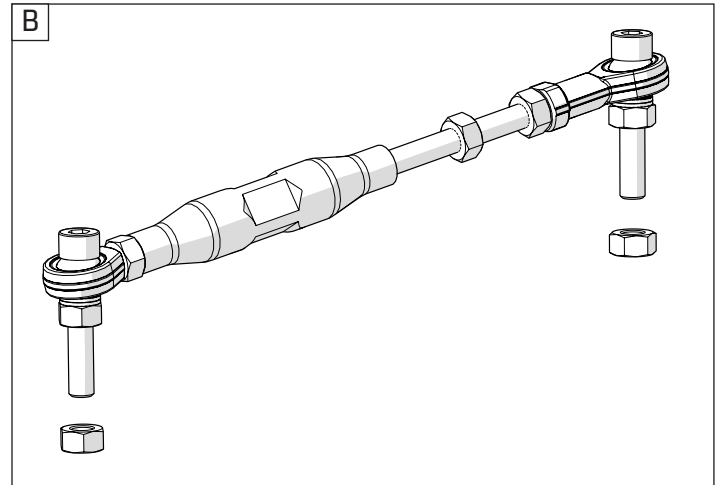
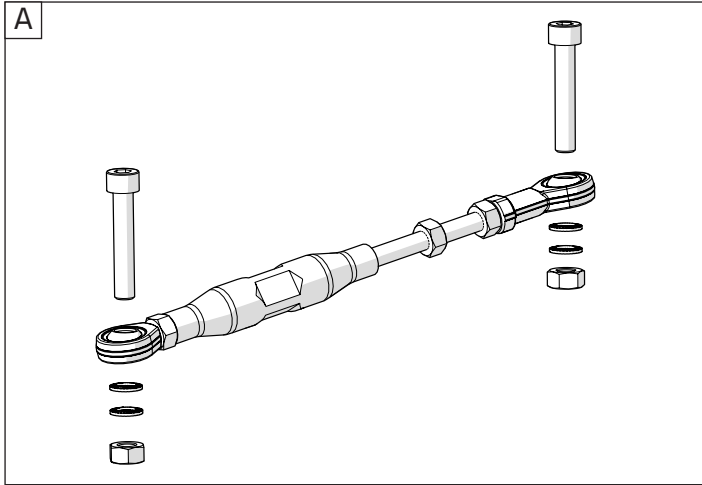



54

ride BULLDOG



2x
Locknut M8

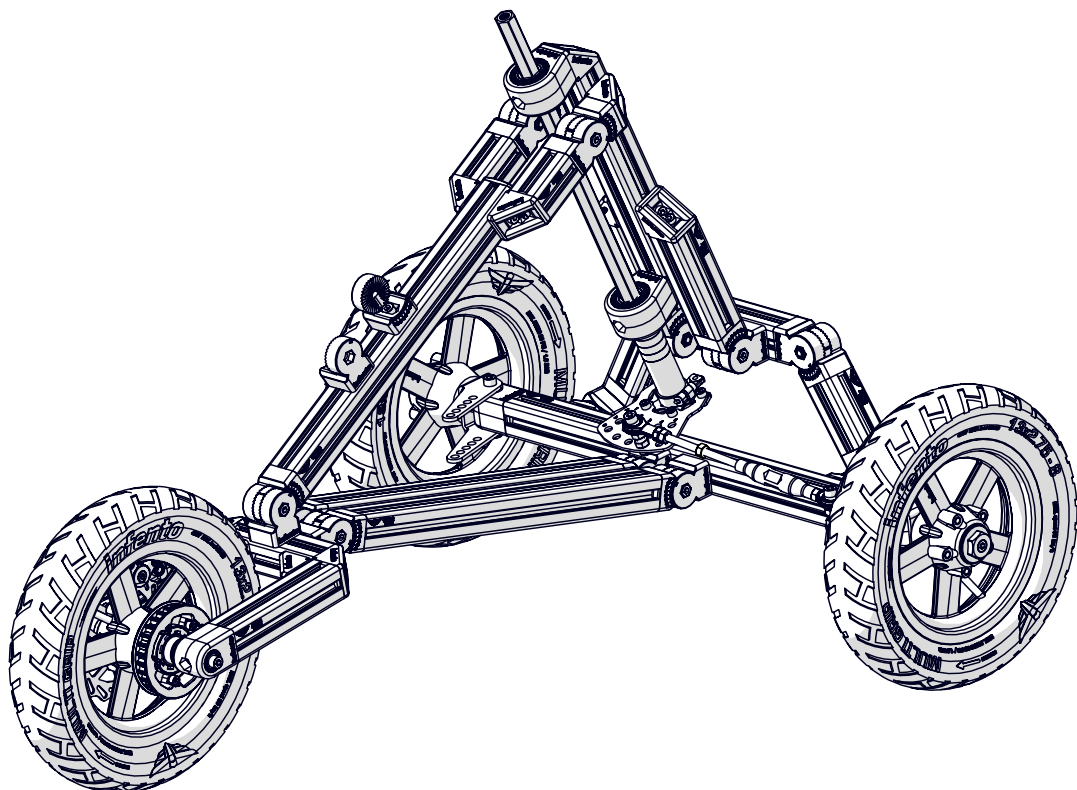
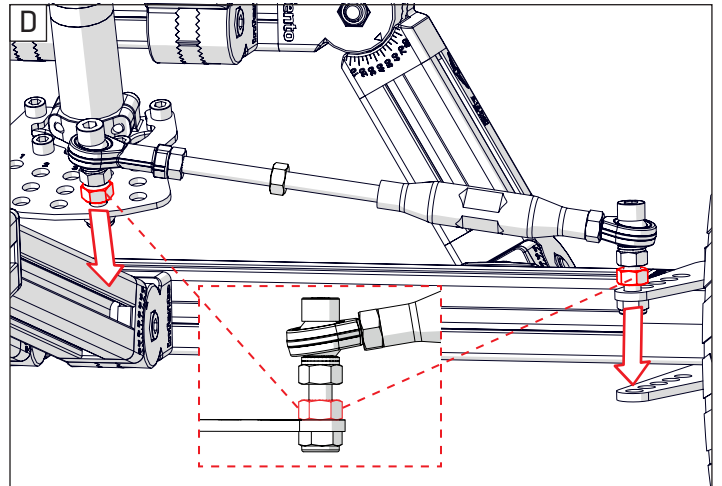
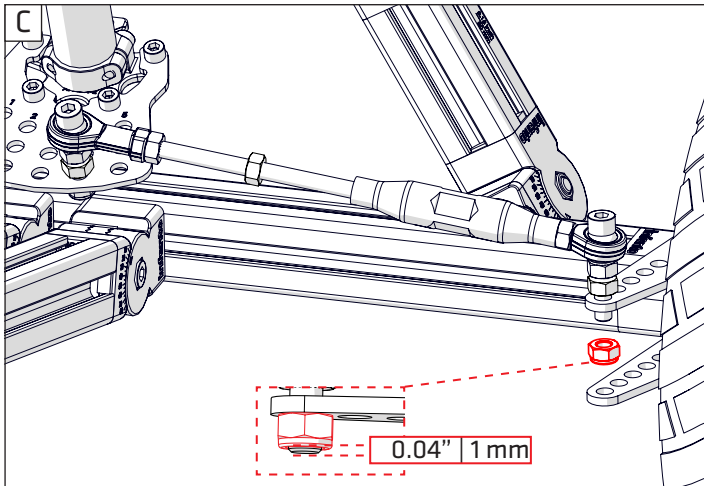
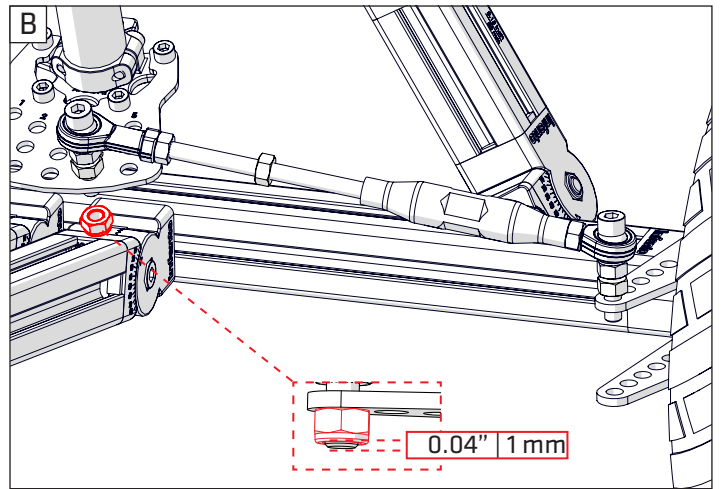
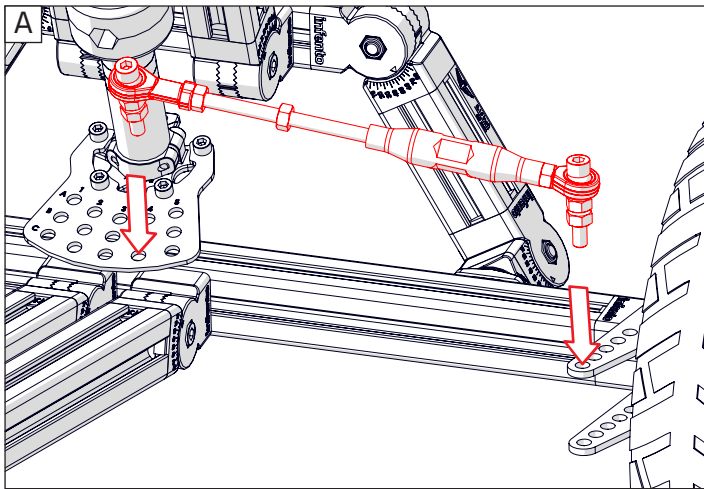



55

ride BULLDOG



2x
Locknut M8

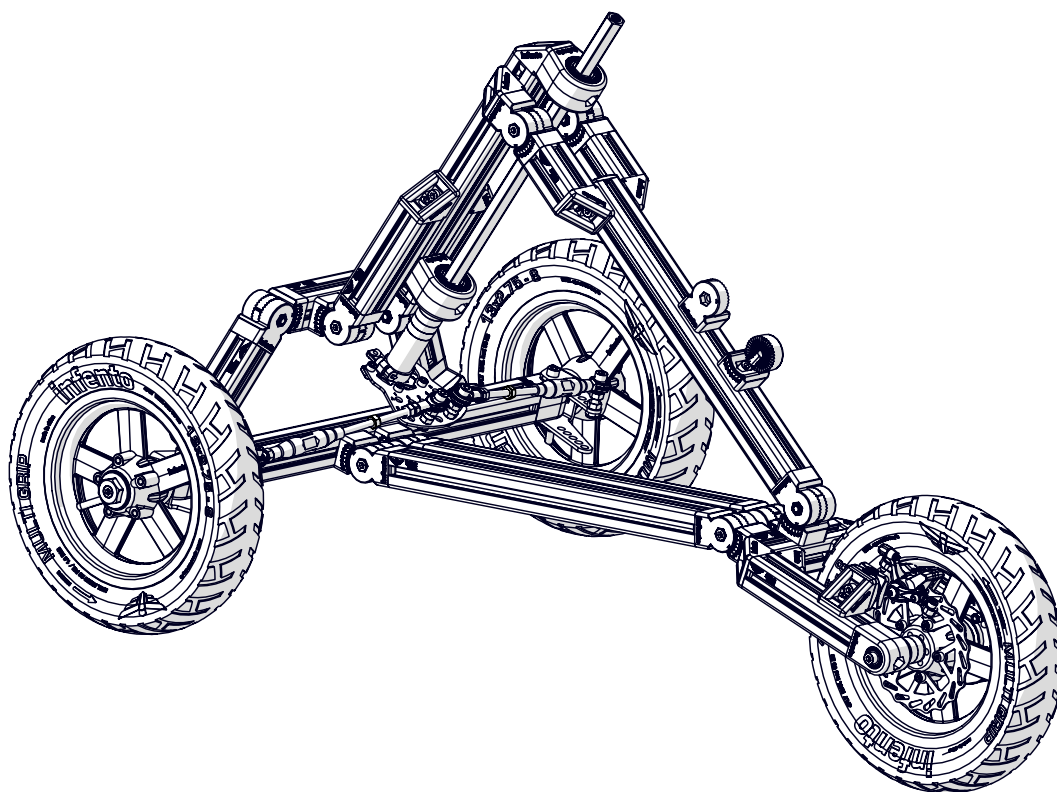
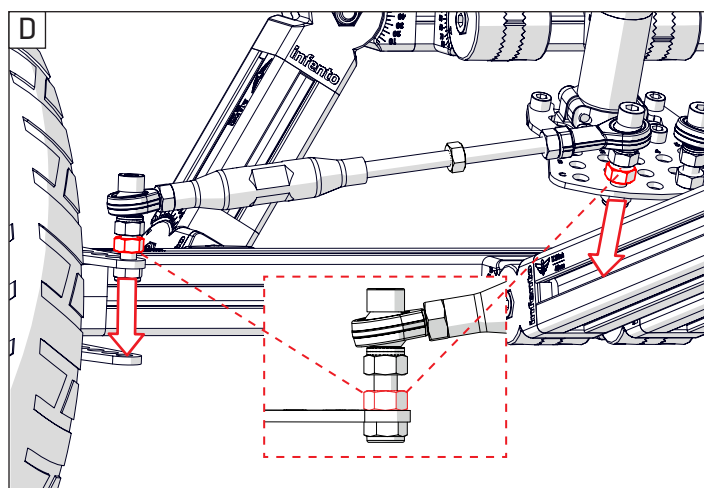
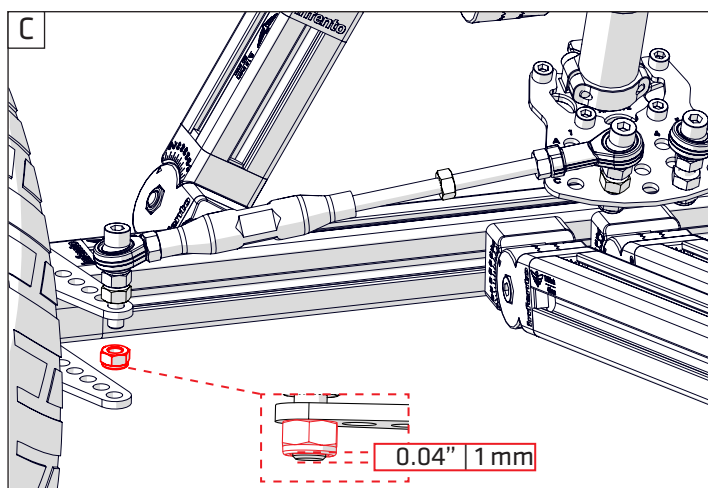
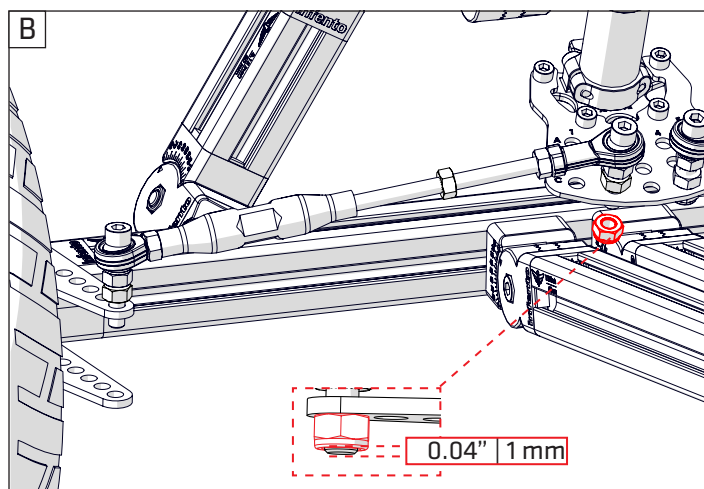
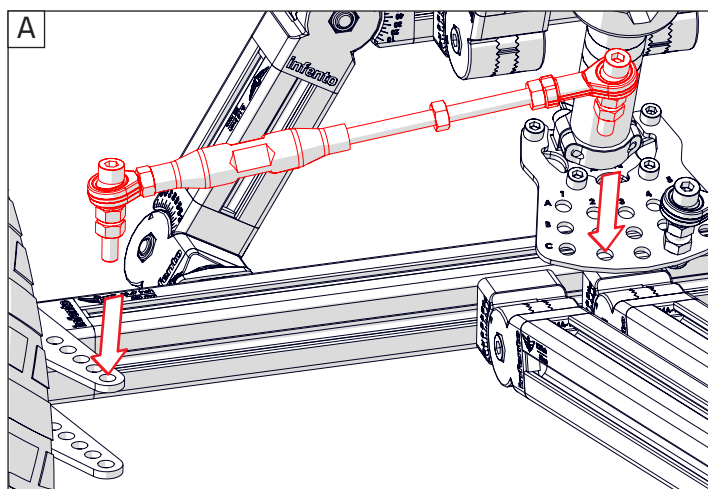



56

ride **BULLDOG**

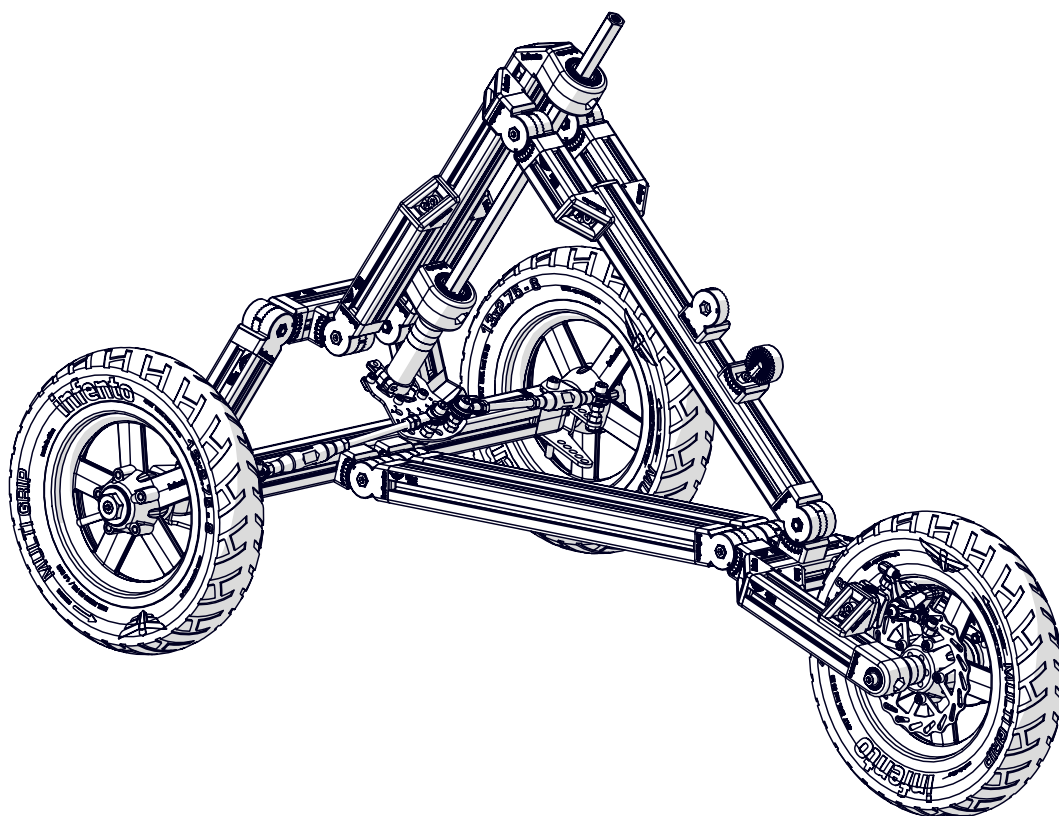
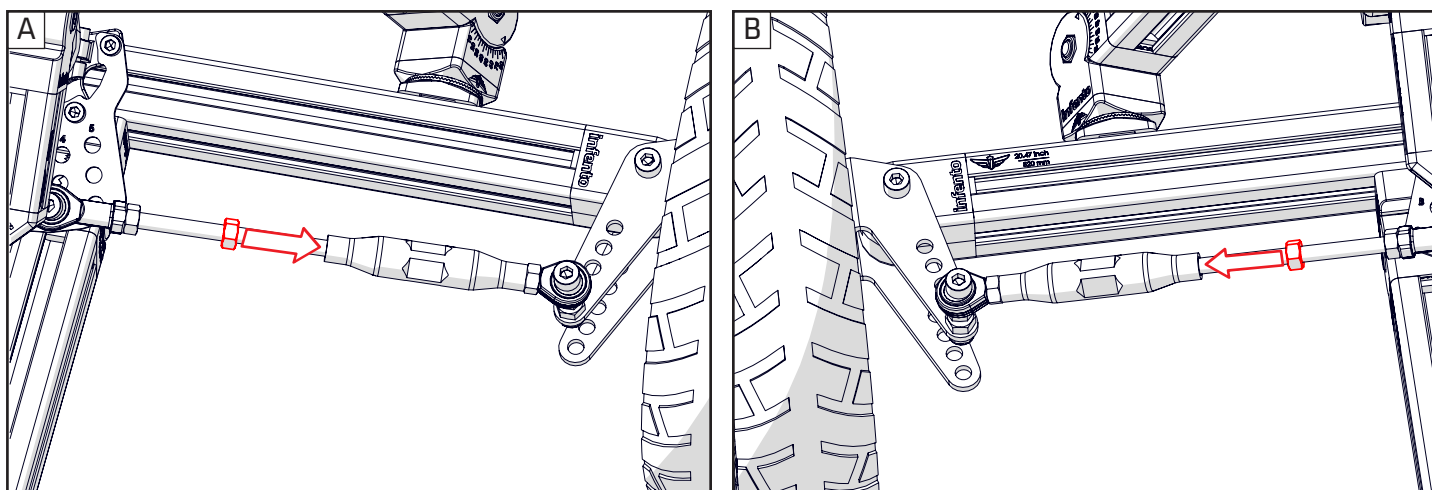



57

ride BULLDOG



2x

Locknut M8



2x



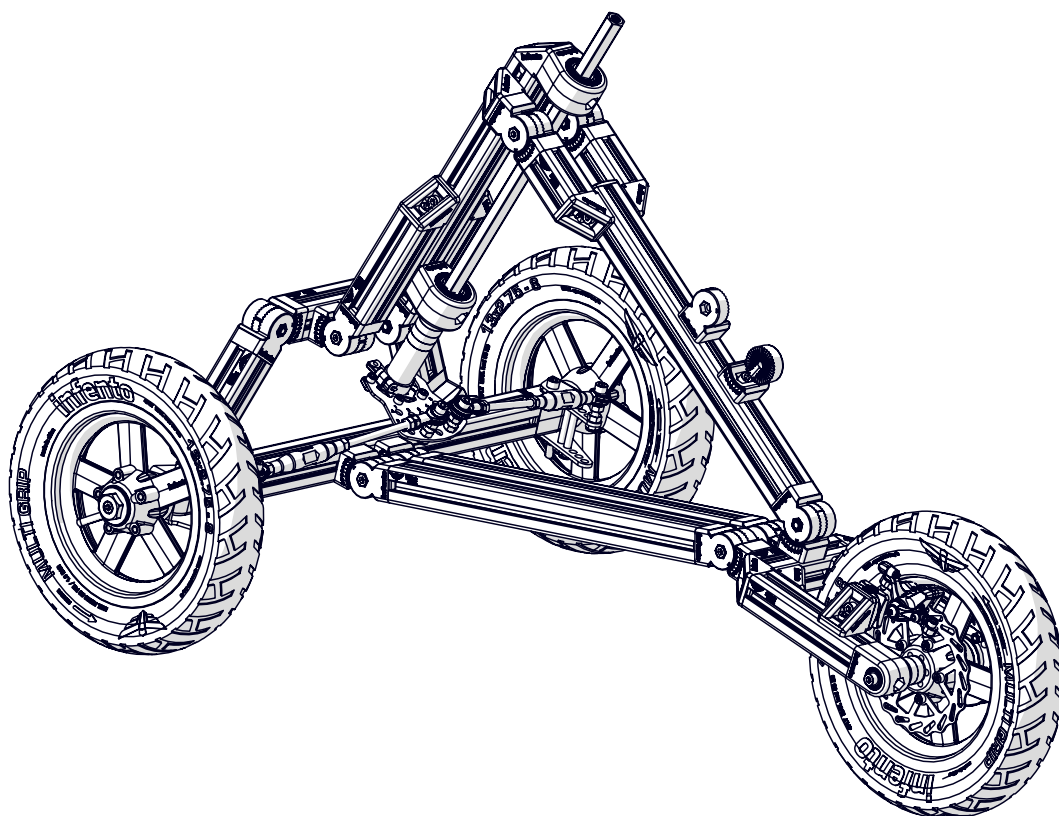
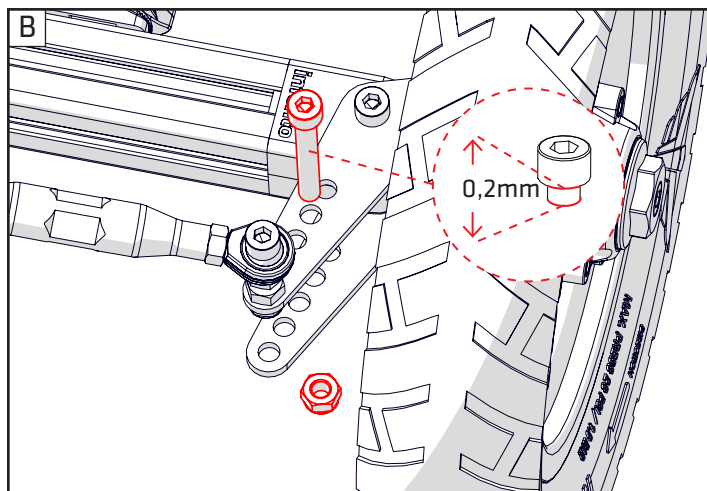
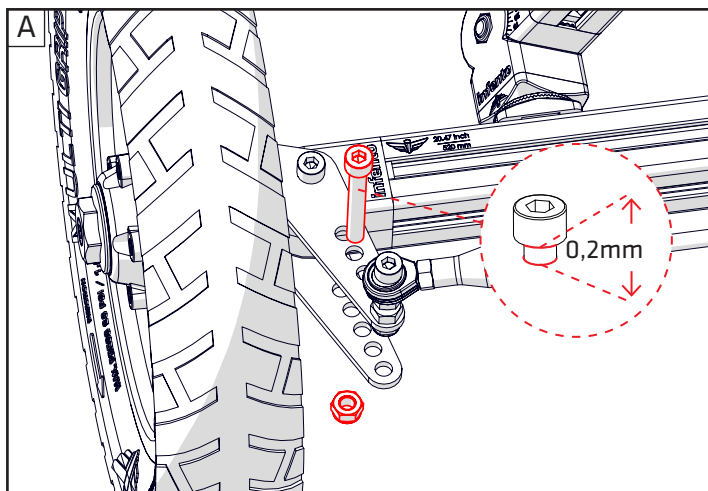

Bolt M8x60



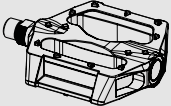

58

ride **BULLDOG**



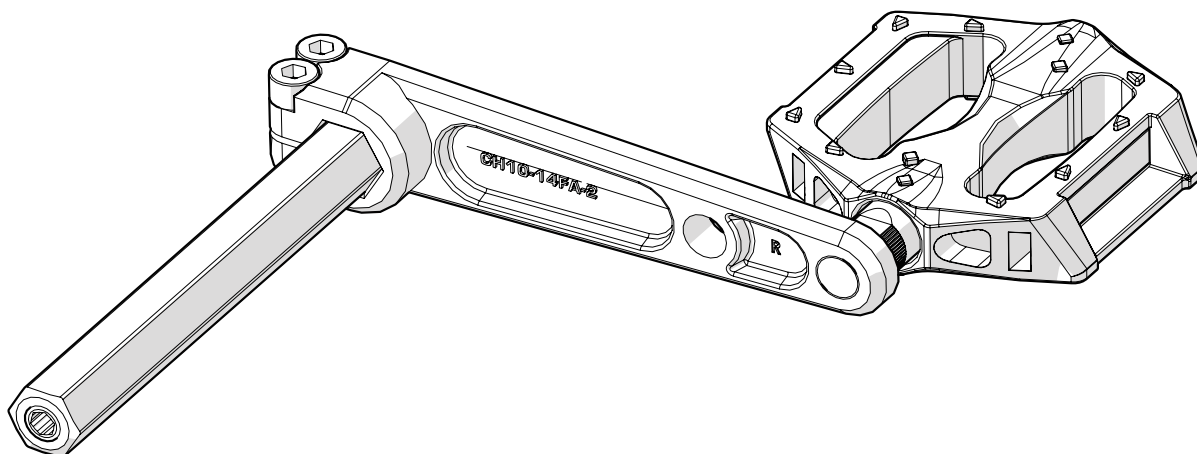
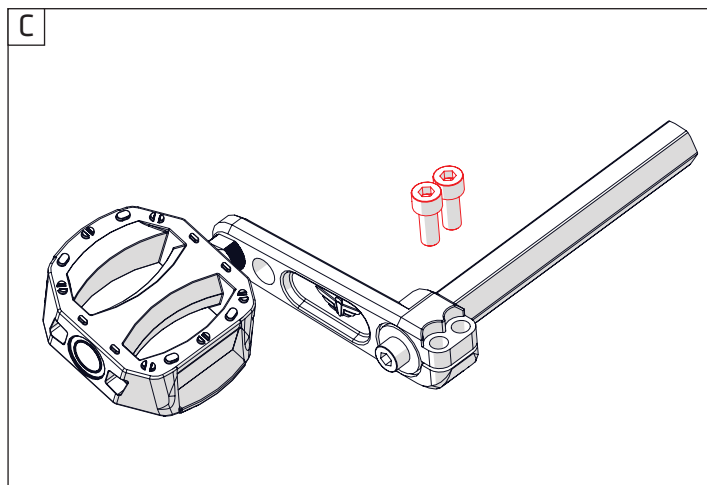
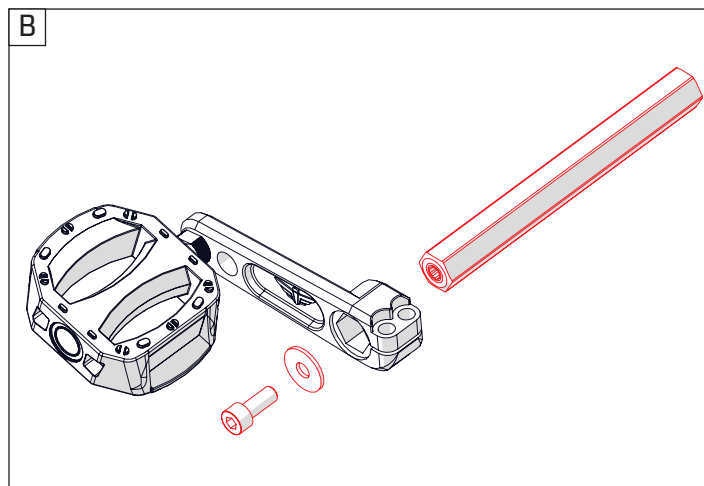
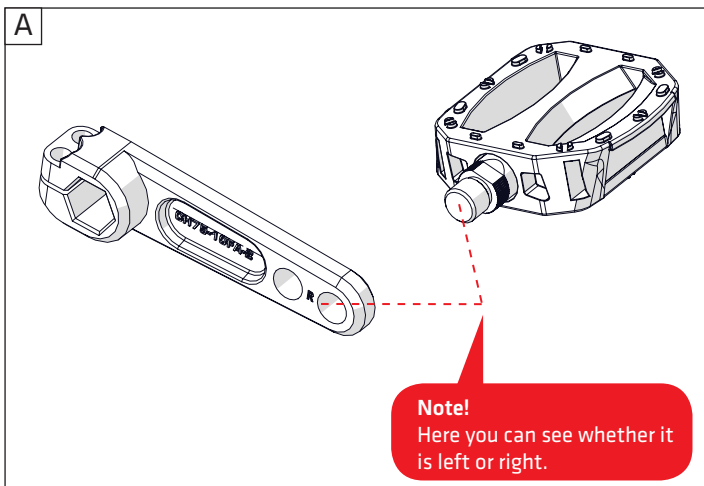

-  3x Bolt M8x20
-  1x Washer M8-24
-  1x Axle 6.77inch | 172mm
-  1x Pedal right
-  1x Crank small right



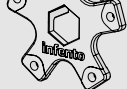

59

ride **BULLDOG**

-  5x Bolt M6x12
-  2x Bolt M6x20
-  1x Clamping part holes with M6 thread
-  1x Axle flange
-  1x Toothed belt pulley 46T

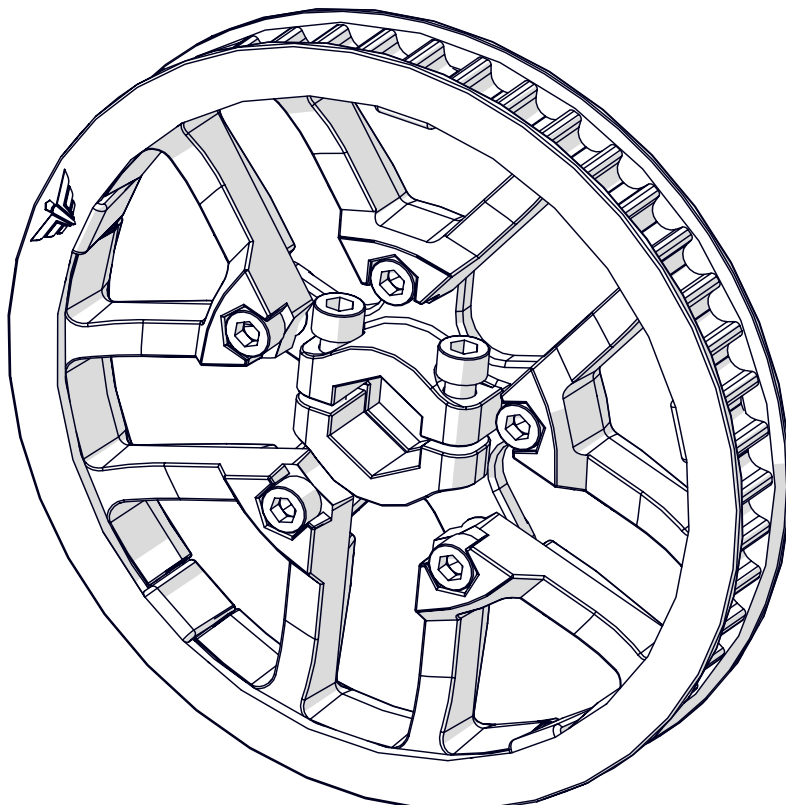
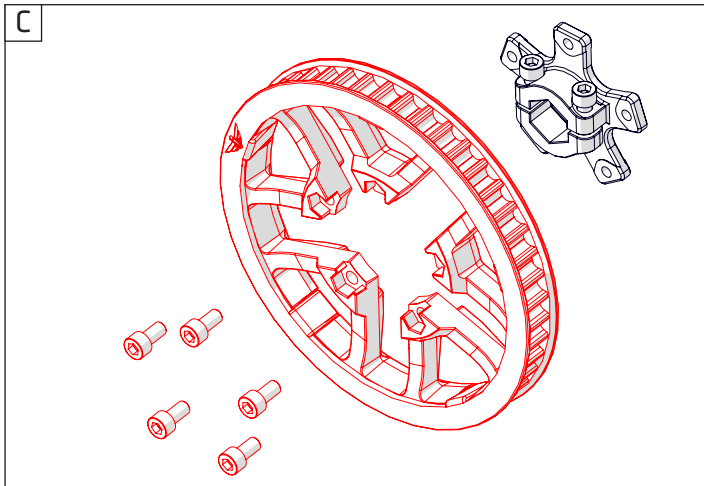
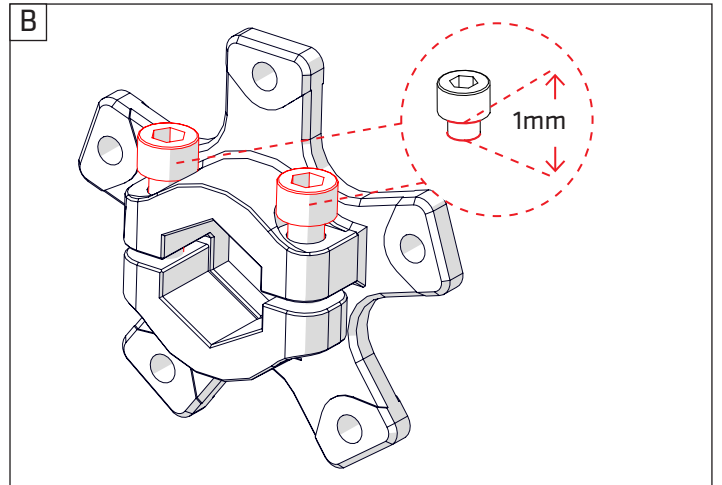
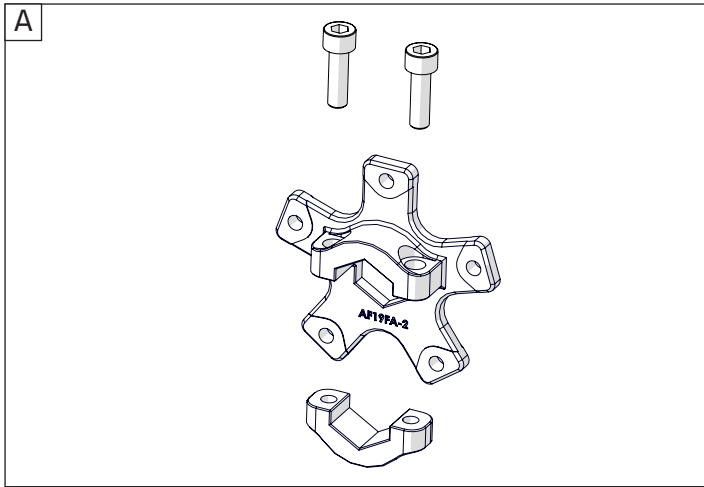



60

ride *BULLDOG*





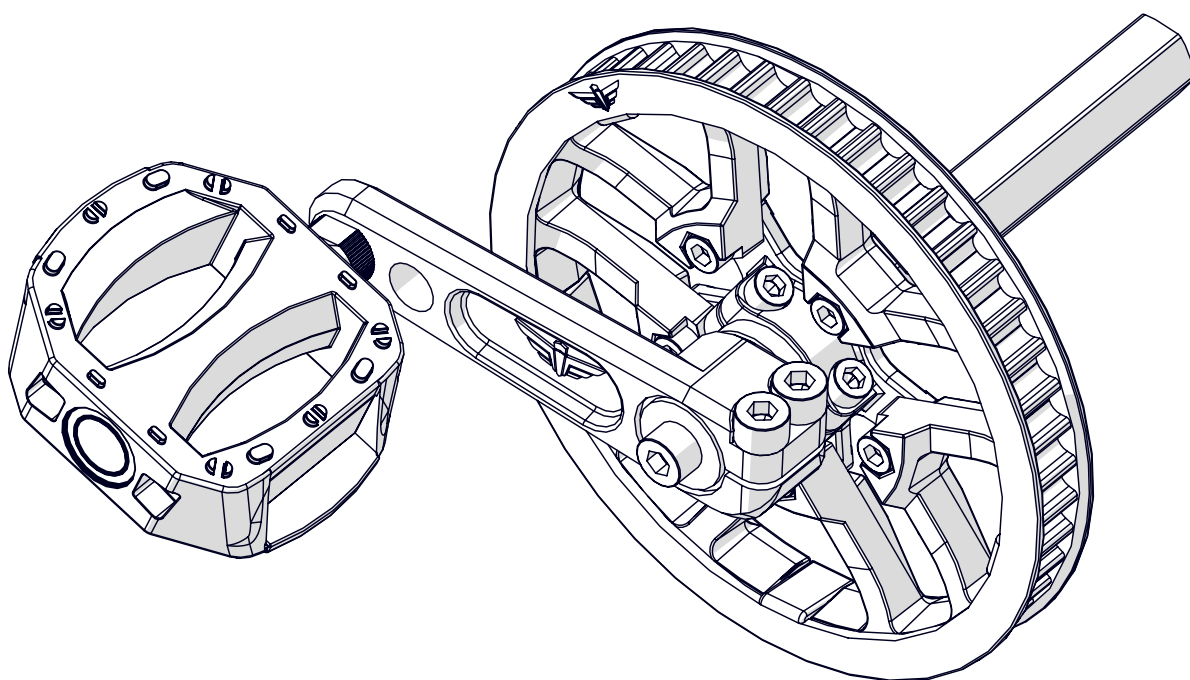
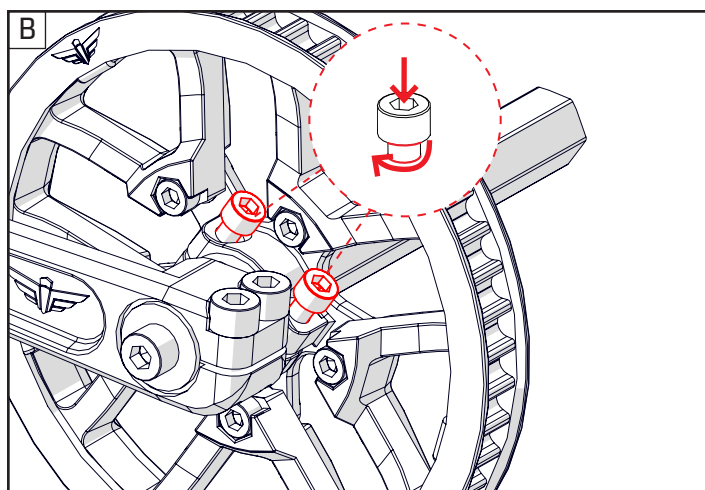
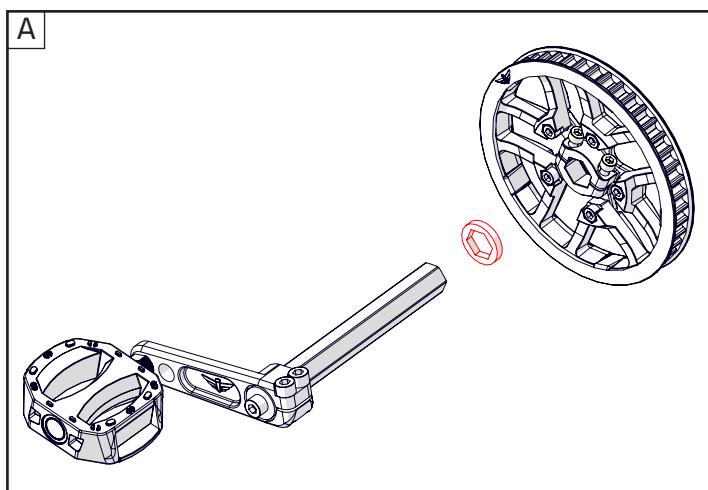

Spacer 1x
0.2inch | 5 mm



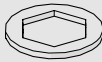

61

ride **BULLDOG**



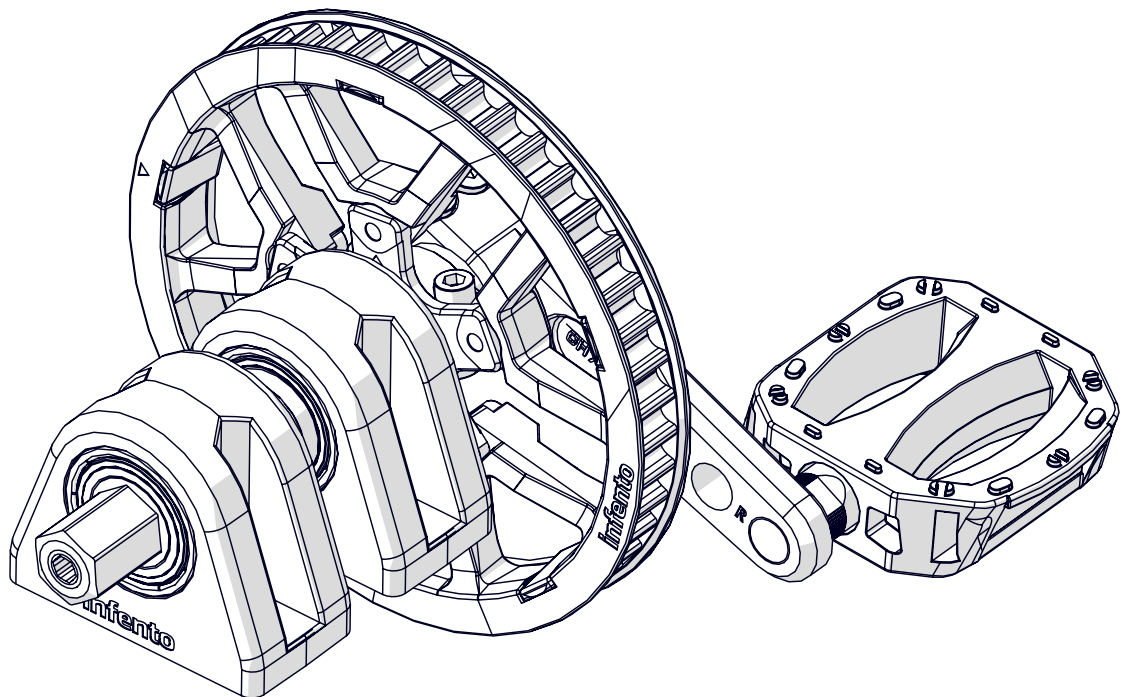
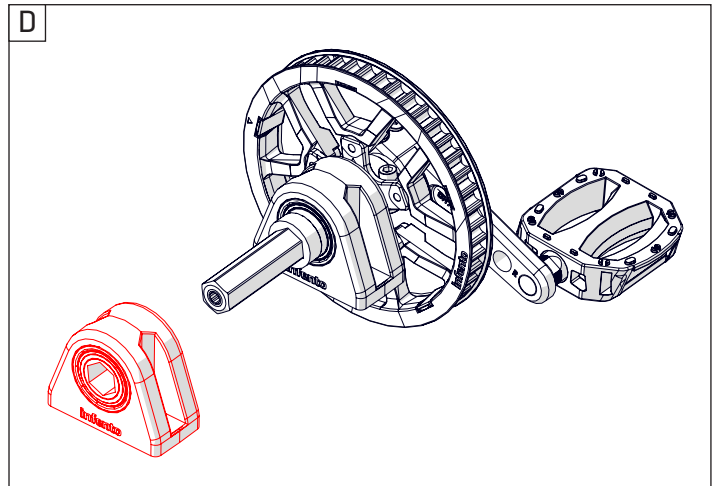
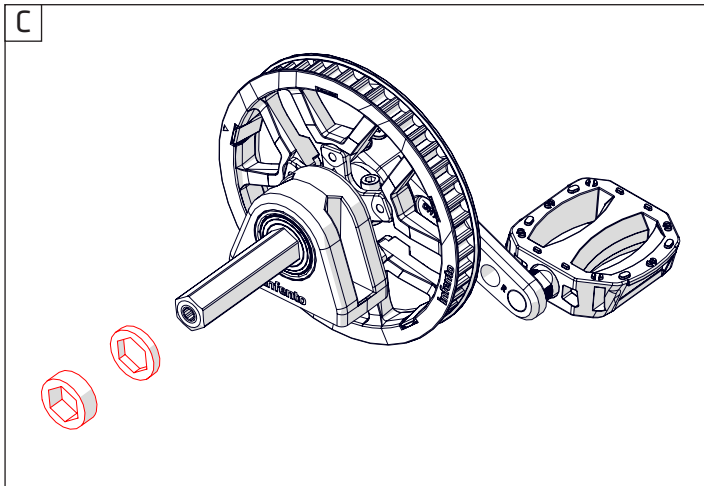
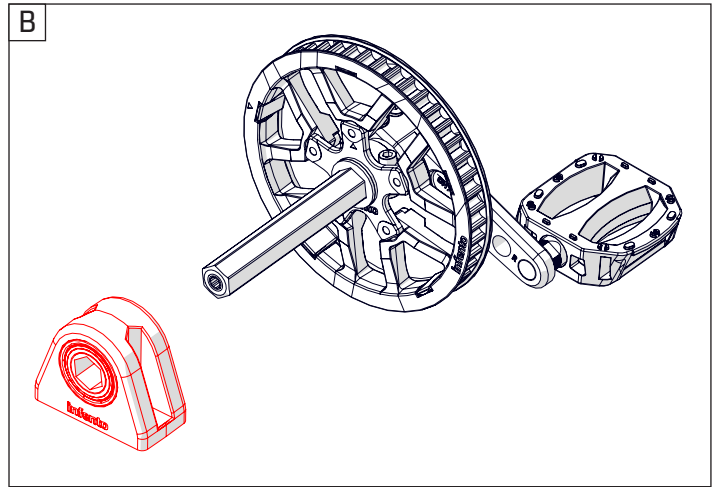
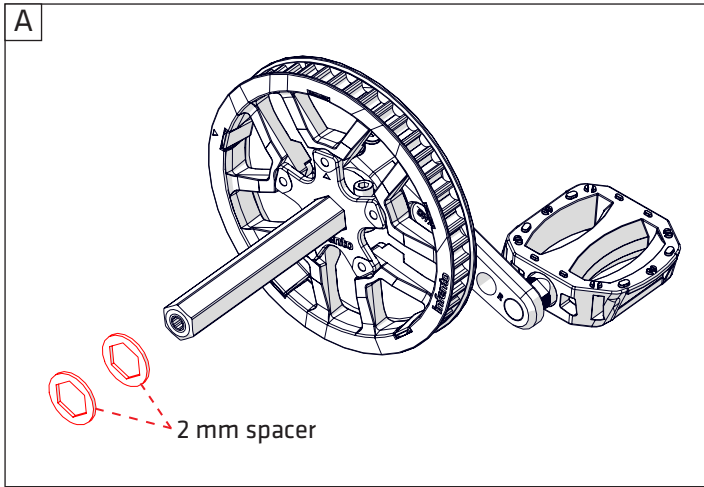

-  +  +  + 
- Spacer 2x
0.08inch | 2 mm
- Spacer 1x
0.2inch | 5 mm
- Spacer 1x
0.39inch | 10mm
- Bearingblock 2x
40x80_hexa 19



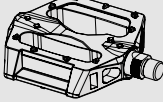

62

ride **BULLDOG**

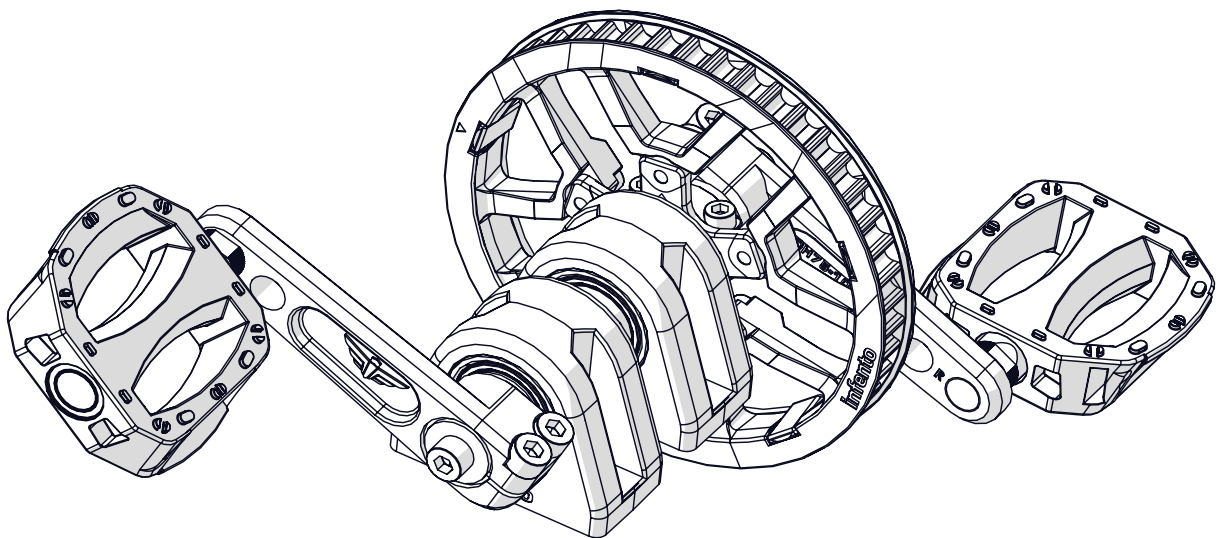
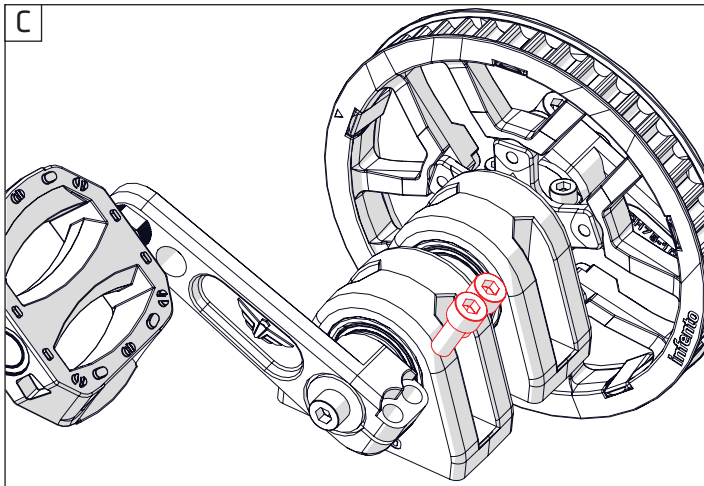
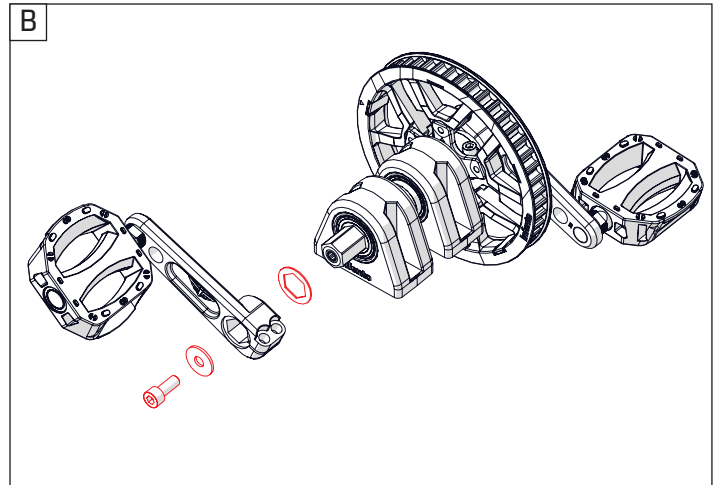
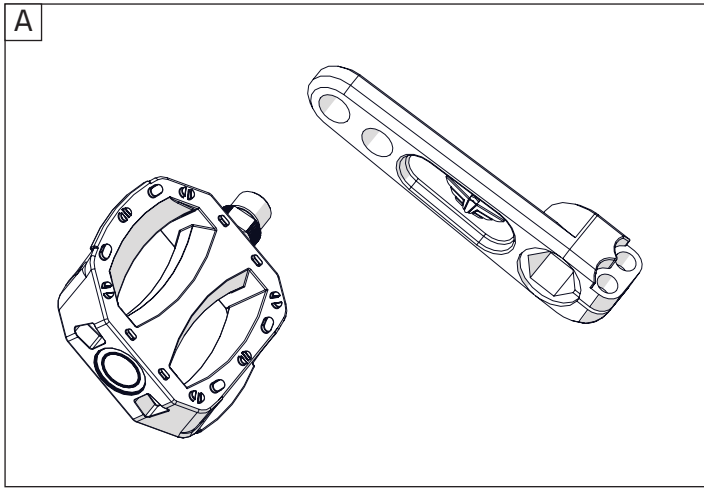

-  3x Bolt M8x20
-  1x Washer M8-24
-  1x Spacer 0.04inch | 1mm
-  1x Pedal left
-  1x Crank small left





63

ride BULLDOG

-  4x
 -  4x
 -  4x
- Profile nut short Bolt M8x20 T-Positioning block

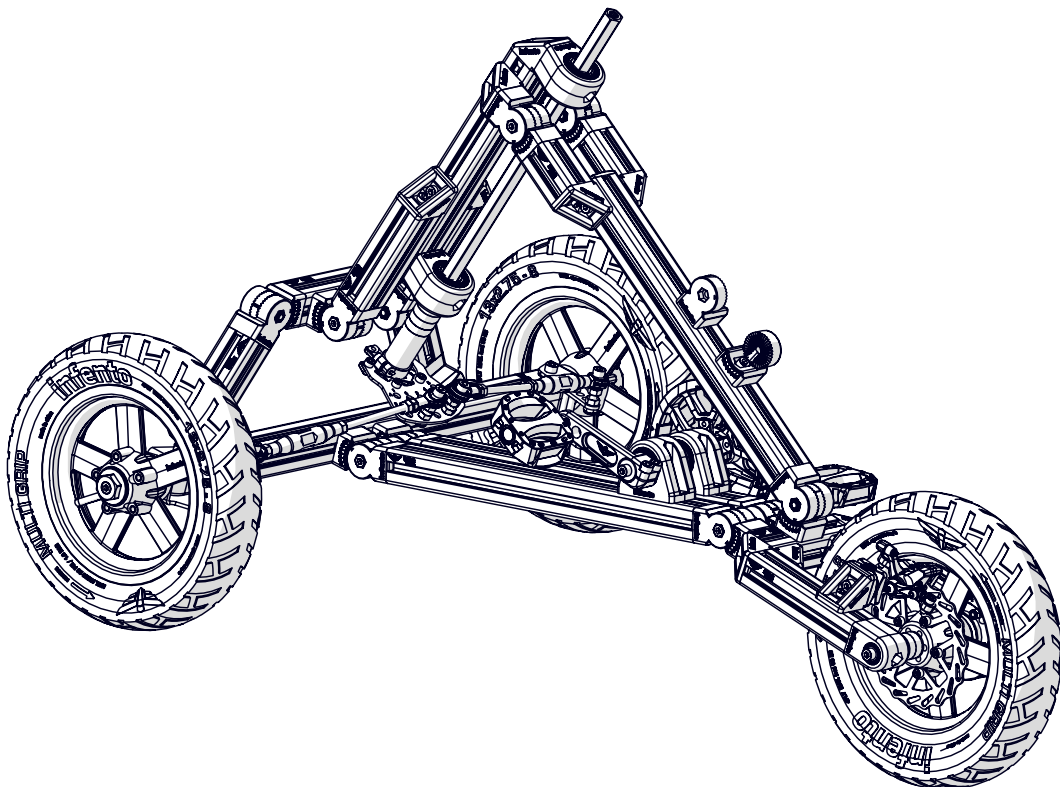
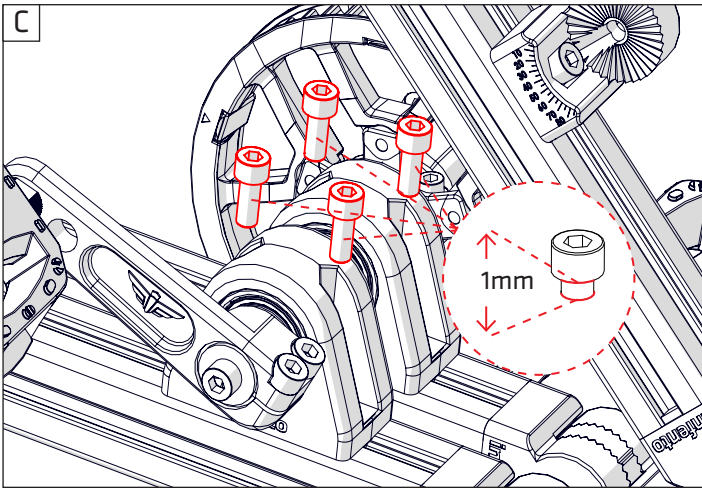
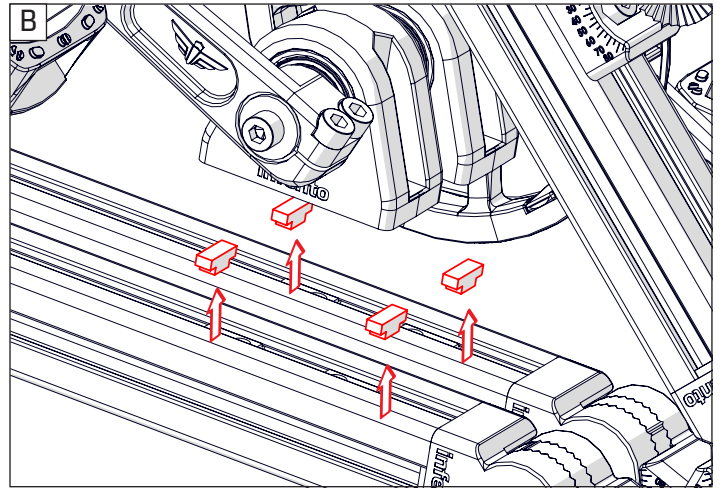
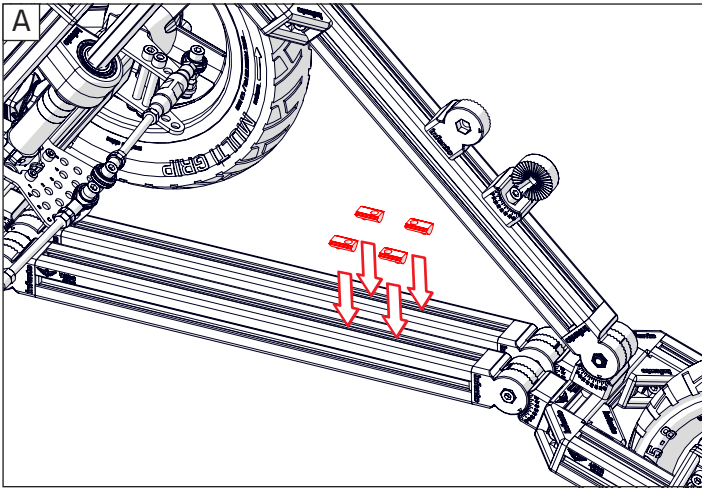



64

ride BULLDOG



1x

Toothed belt 118T

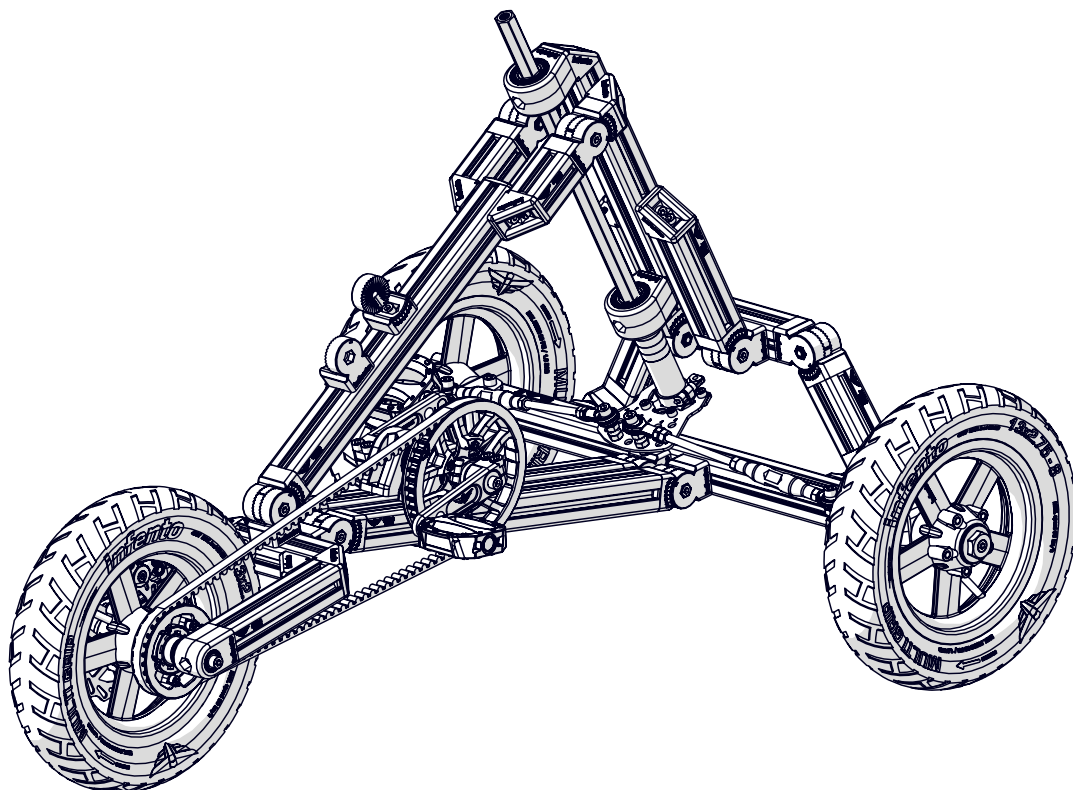
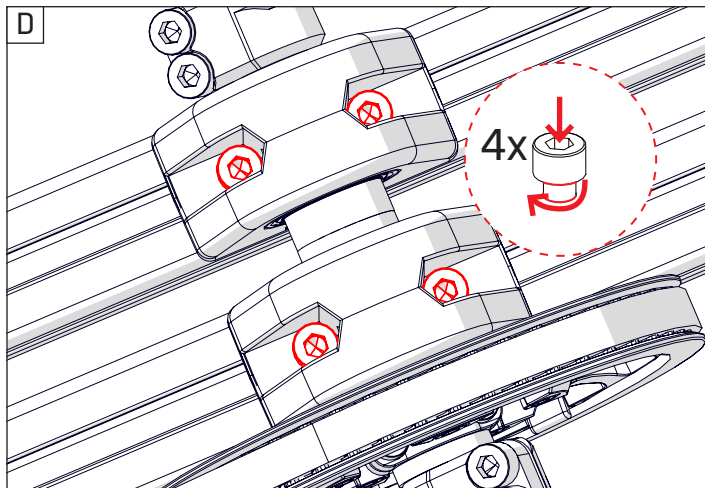
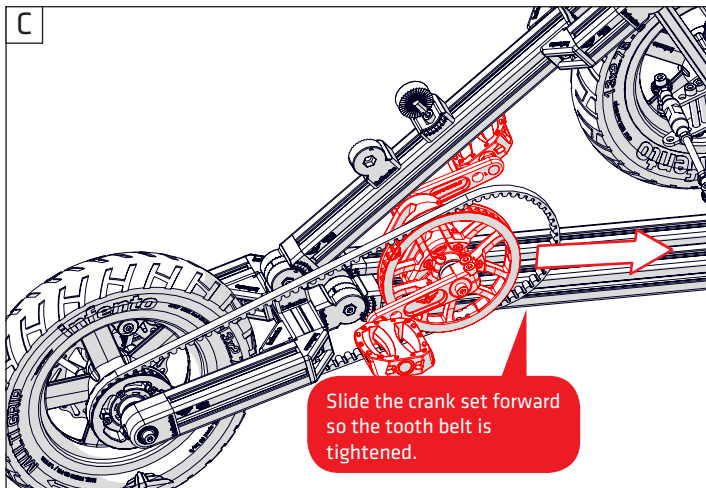
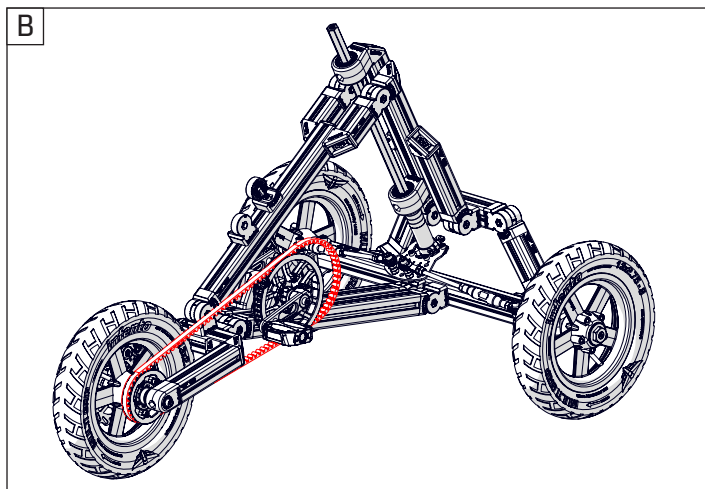
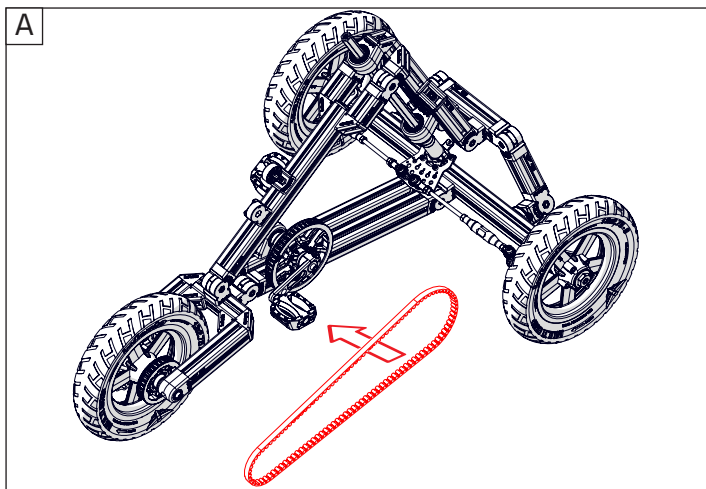



65

ride **BULLDOG**

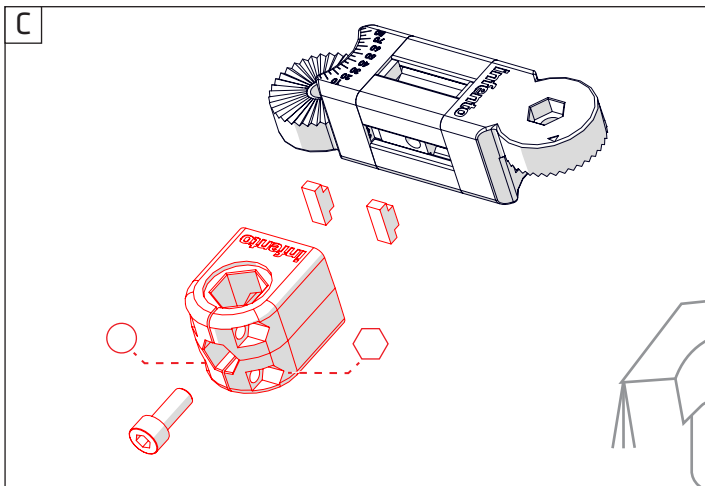
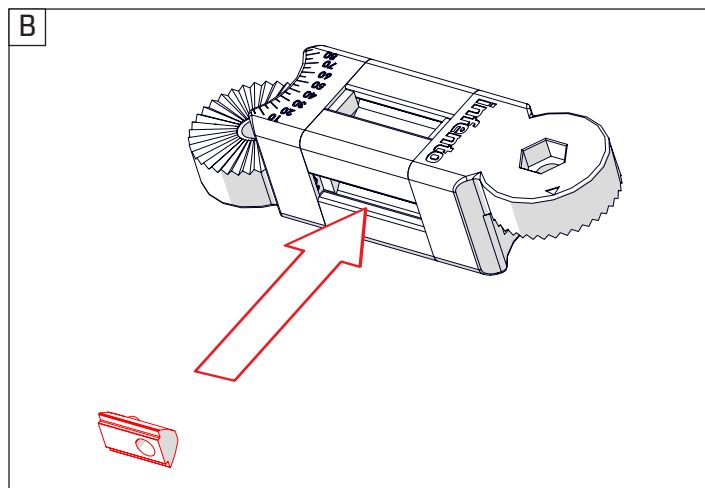
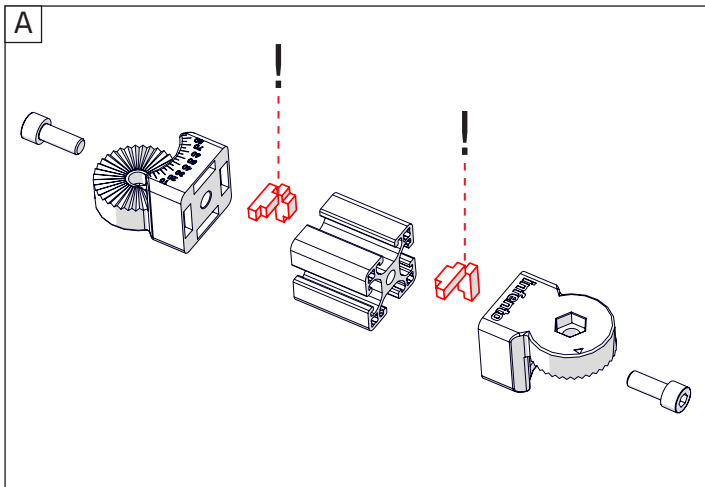
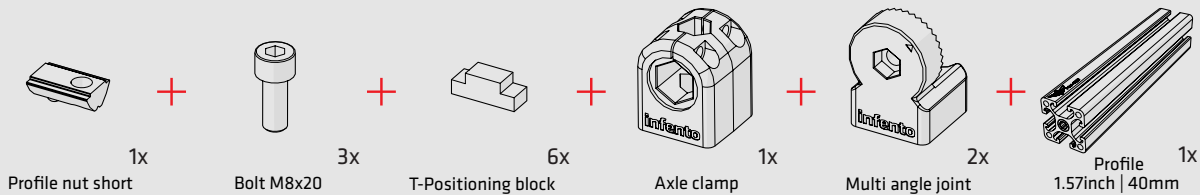



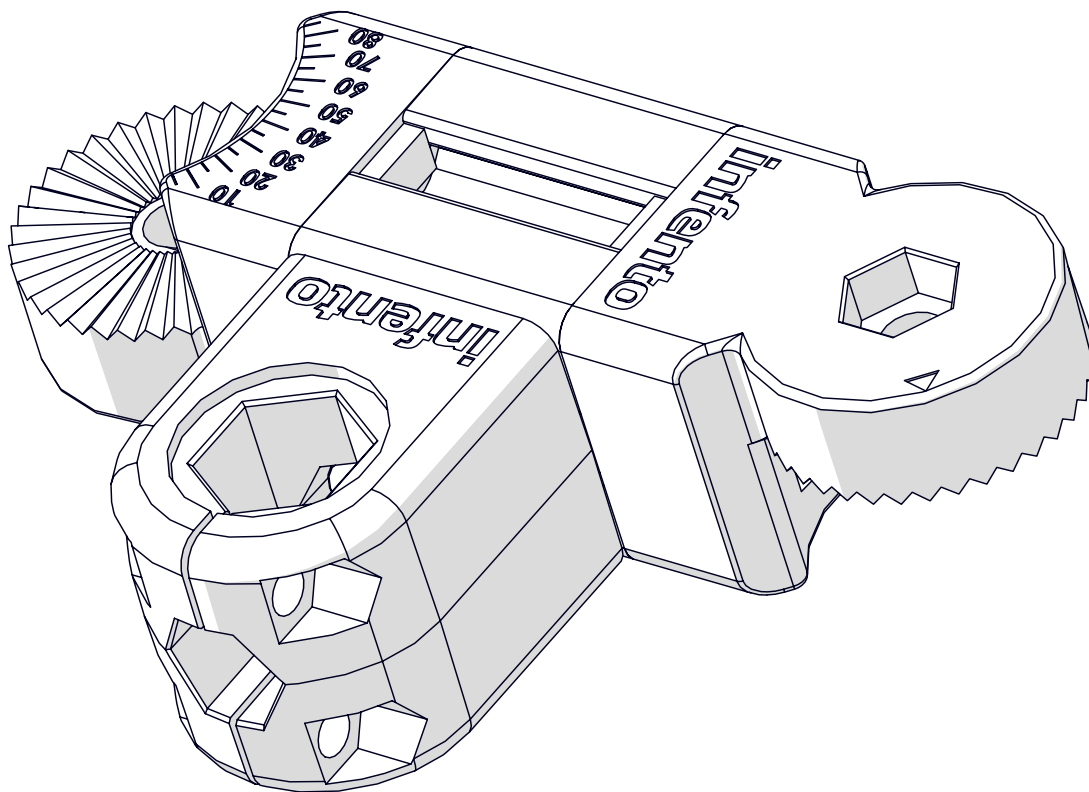

If you look carefully you can see that the sides of the profile slope slightly inwards. If you tighten a bolt securely the profile will be pulled flush against the block so the profile is properly tensioned. As a result the bolts remain more tightly in place. This is called tensile stress.







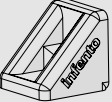

66

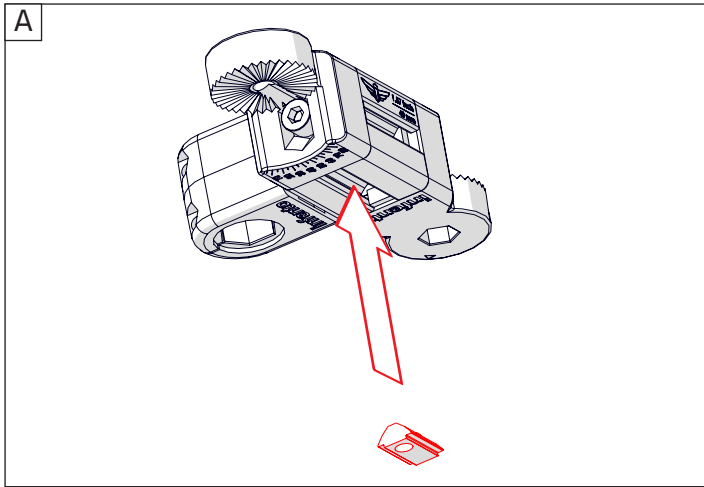
ride **BULLDOG**

- 
 +
 - 
 +
 - 
 +
 - 
 +
 - 
 +
- Positioning block 2x Locknut M8 1x Bolt M8x25 (low head) 1x Axle clamp 1x L-joint 1x



- 
 +
 - 
 +
 - 
 +
- Profile nut short 1x Bolt M8x20 (low head) 1x T-Positioning block 2x

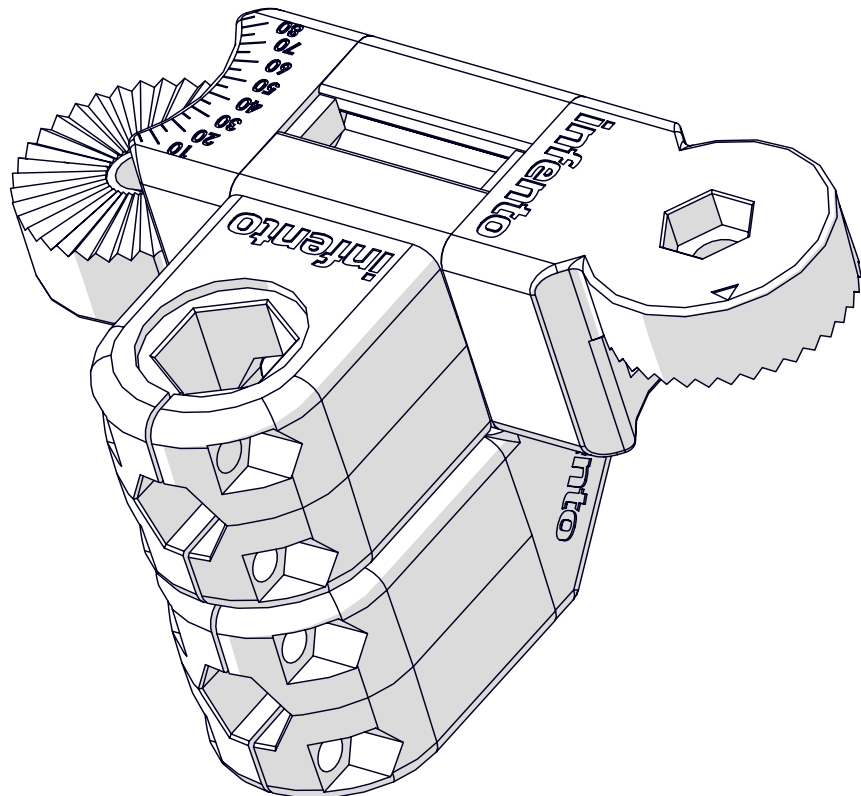
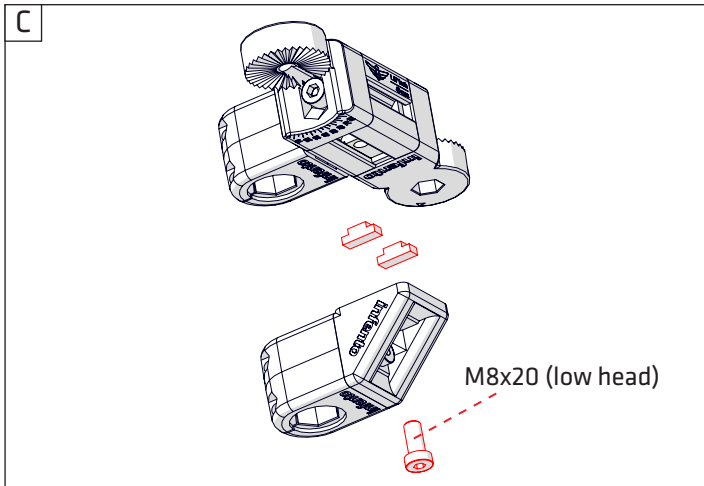
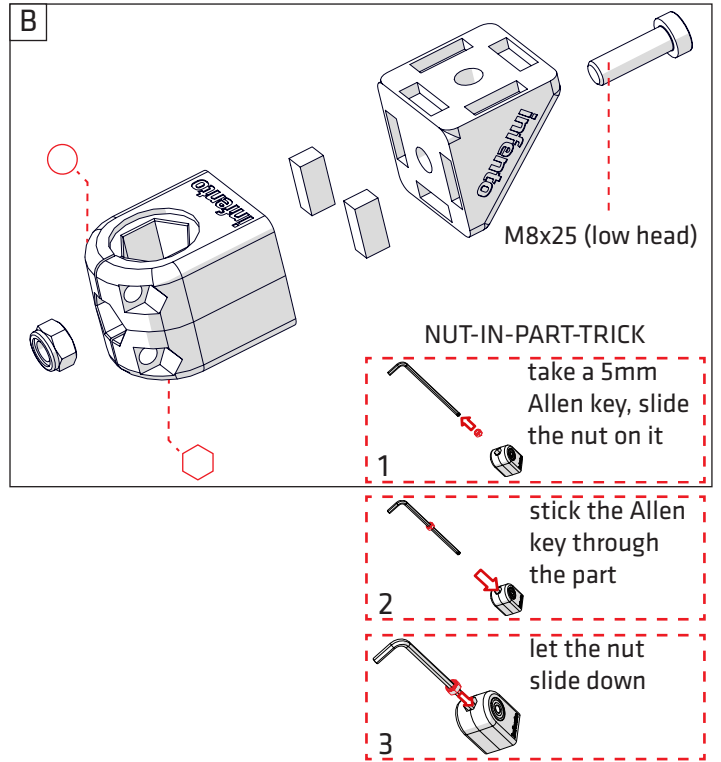



67

ride **BULLDOG**



4x

Locknut M6



4x
Bolt M6x25



1x
Washer M8-24



1x
Bolt M8x20

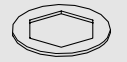

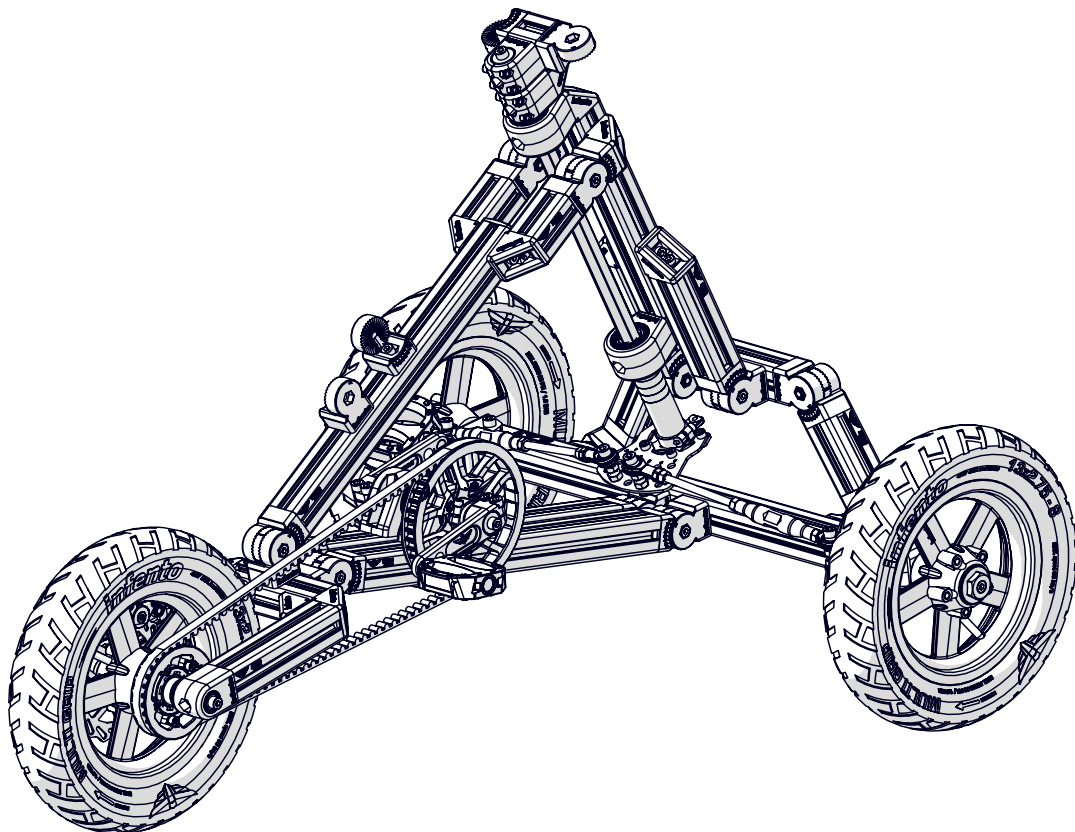
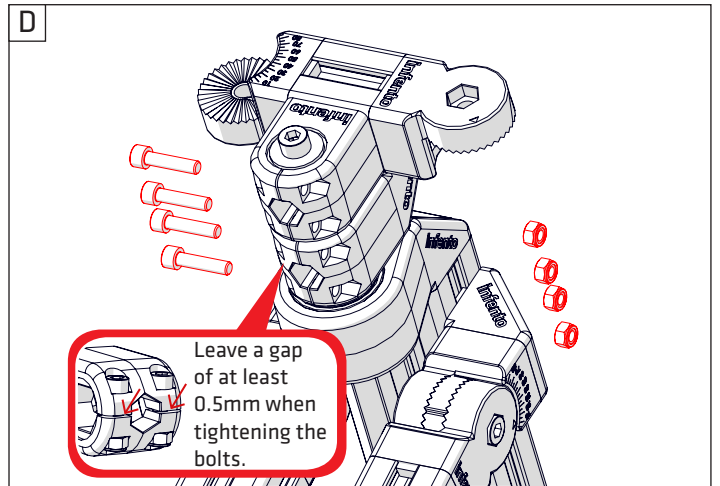
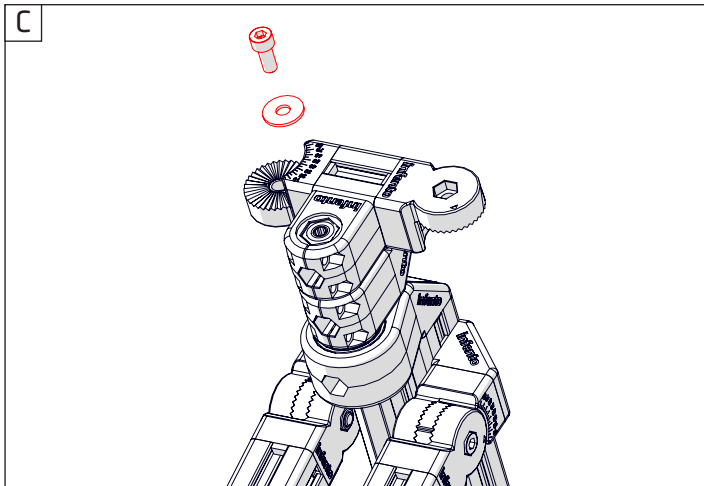
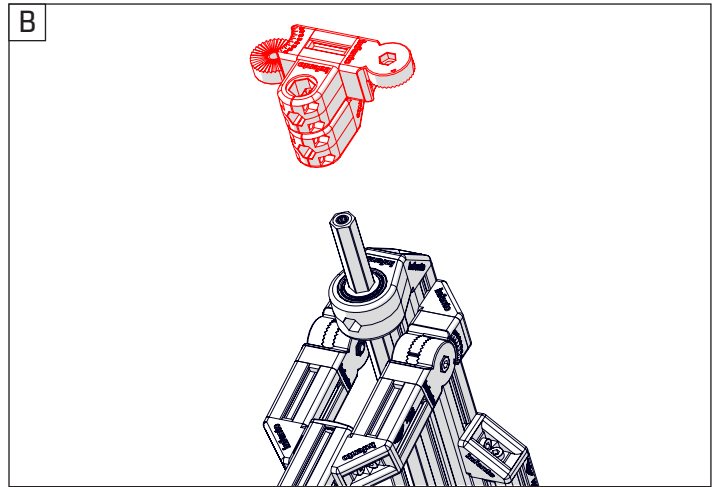
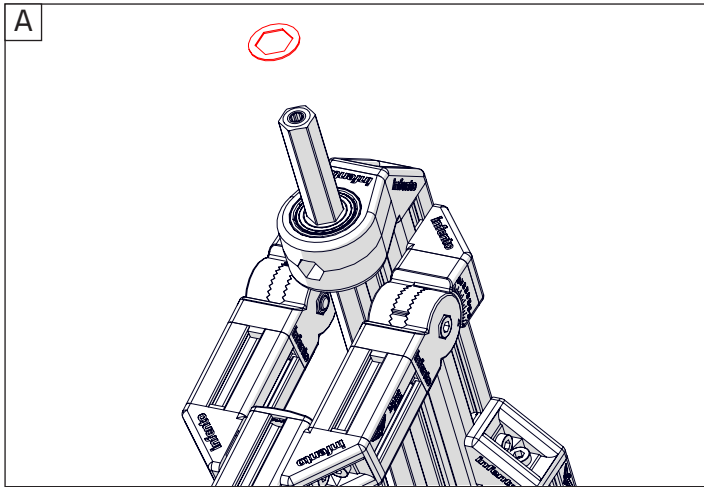

1x
Spacer 0.04inch | 1 mm





68

ride **BULLDOG**

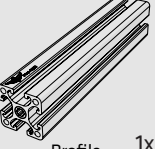
-  2x
-  1x
-  1x
-  1x

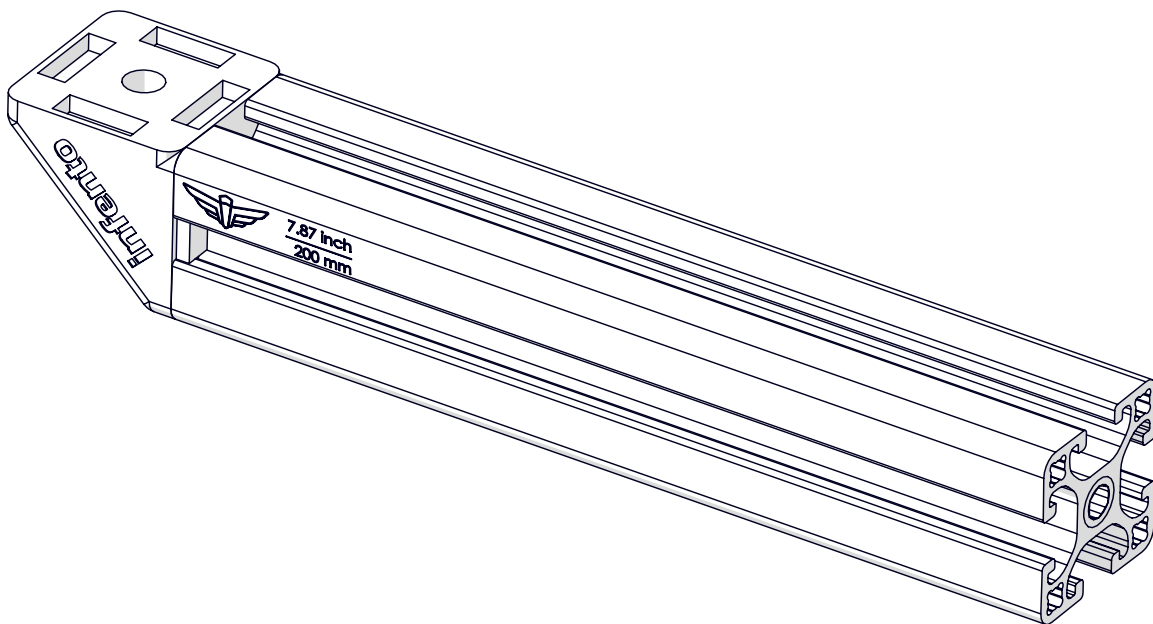
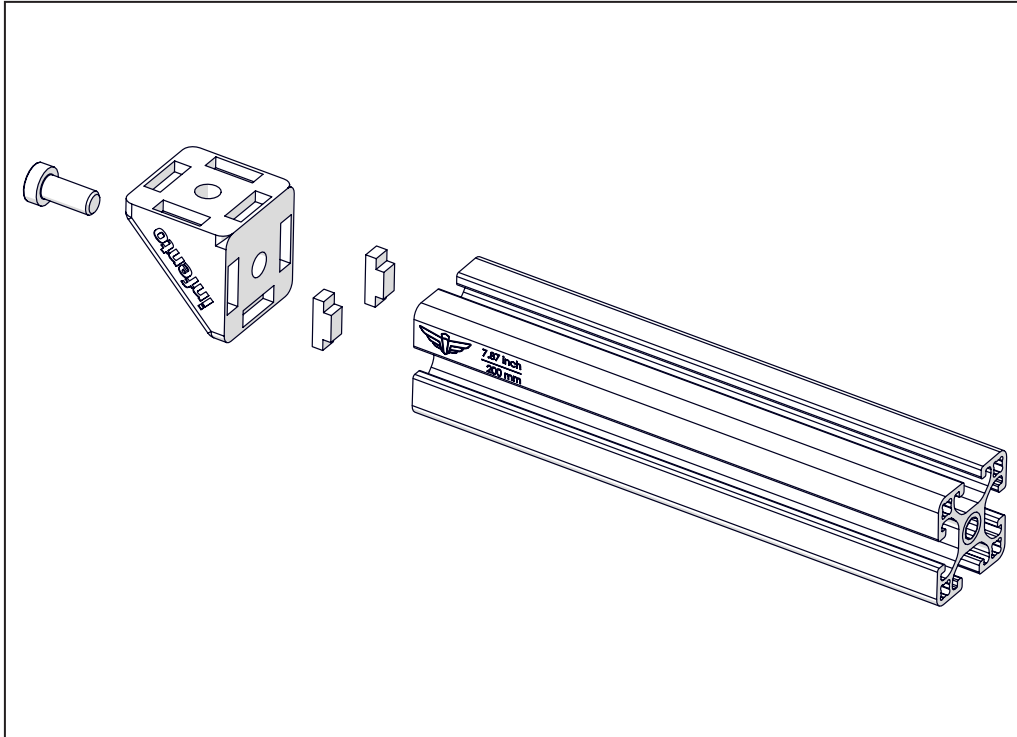



69

ride **BULLDOG**

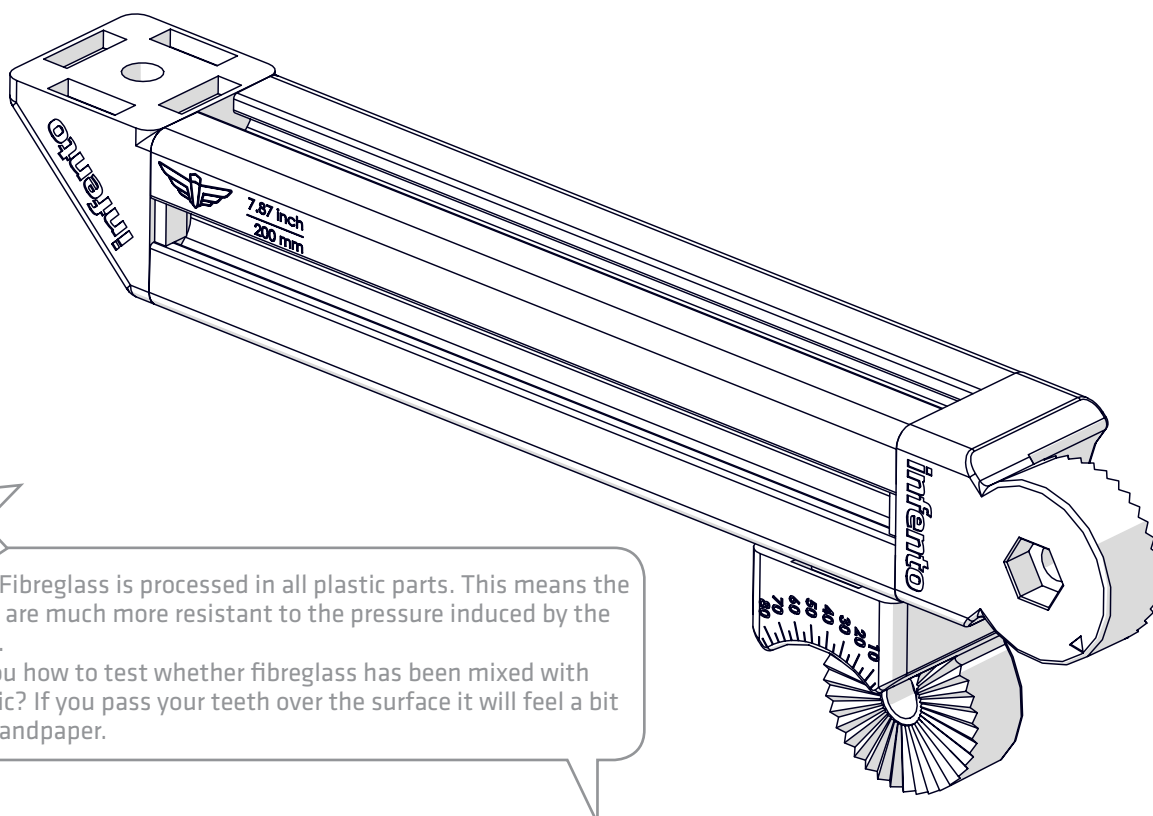
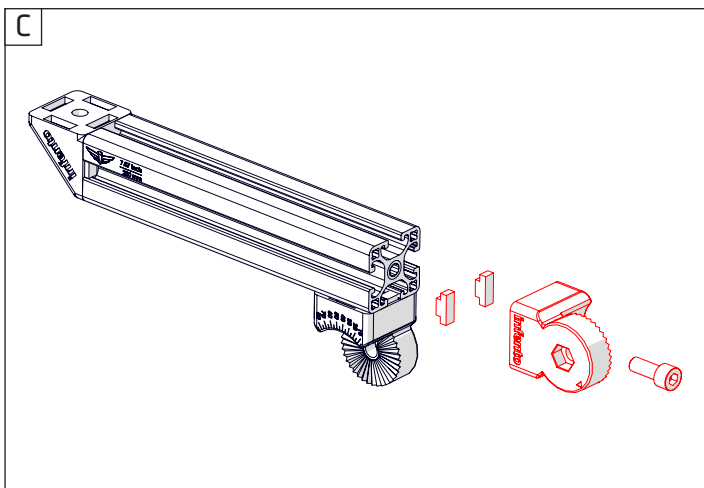
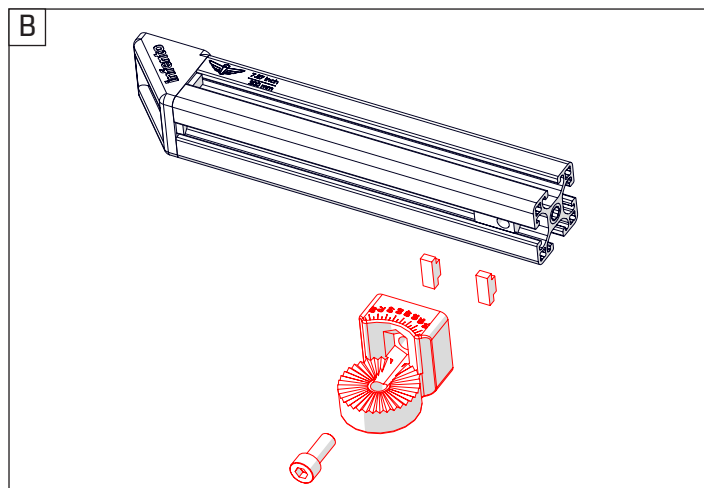
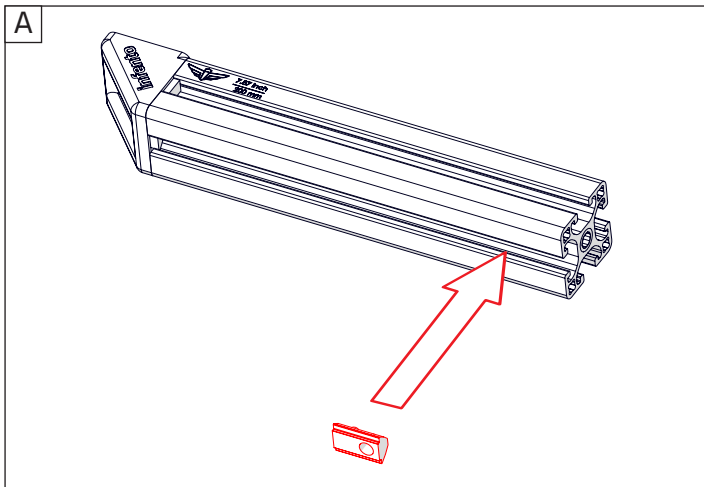
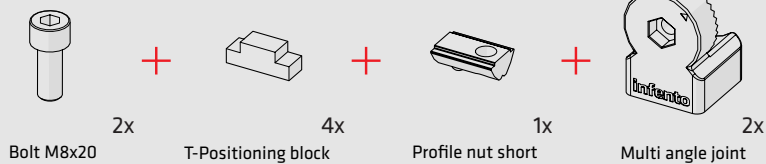

Fibreglass is processed in all plastic parts. This means the parts are much more resistant to the pressure induced by the bolts.
Do you how to test whether fibreglass has been mixed with plastic? If you pass your teeth over the surface it will feel a bit like sandpaper.



70

ride **BULLDOG**



2x

Bolt M8x35



2x

Locknut M8

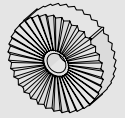

2x



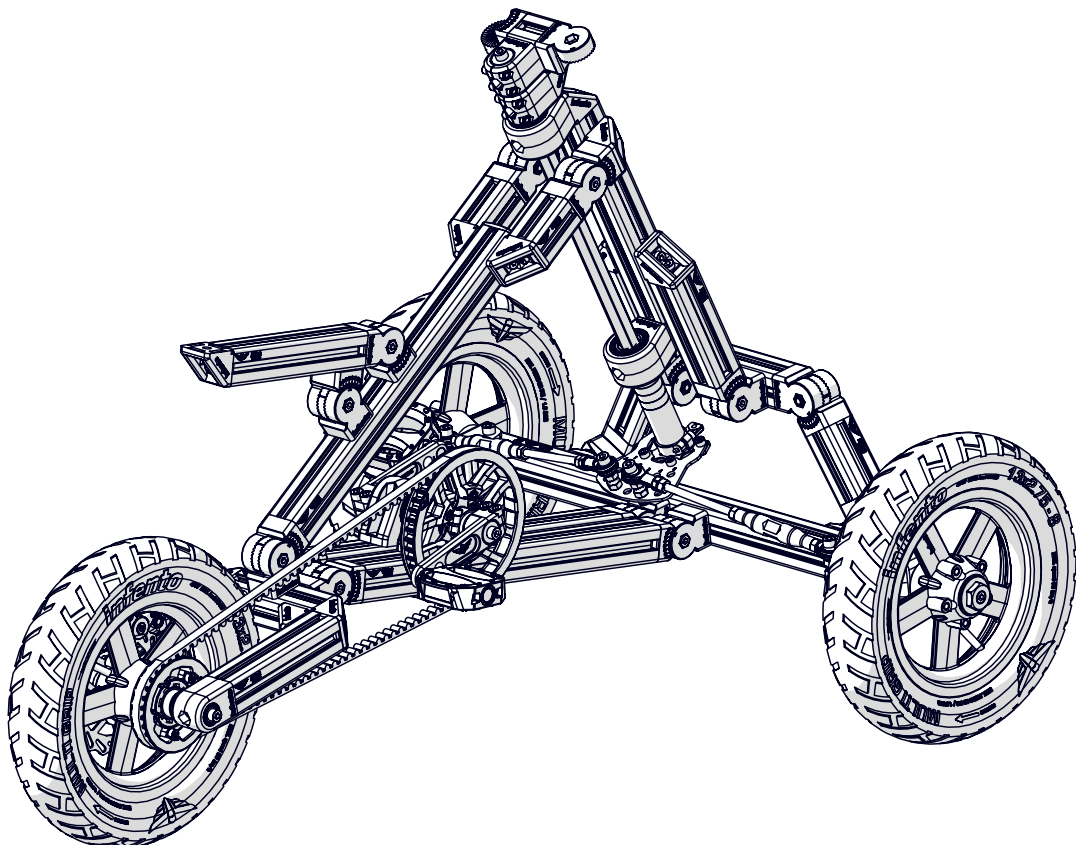
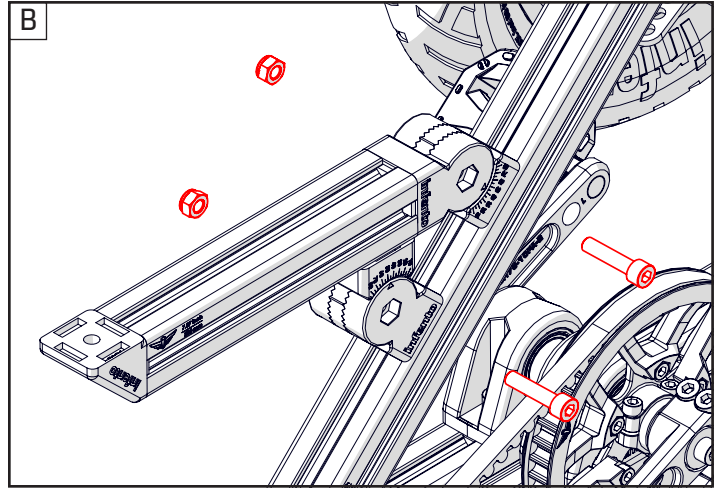
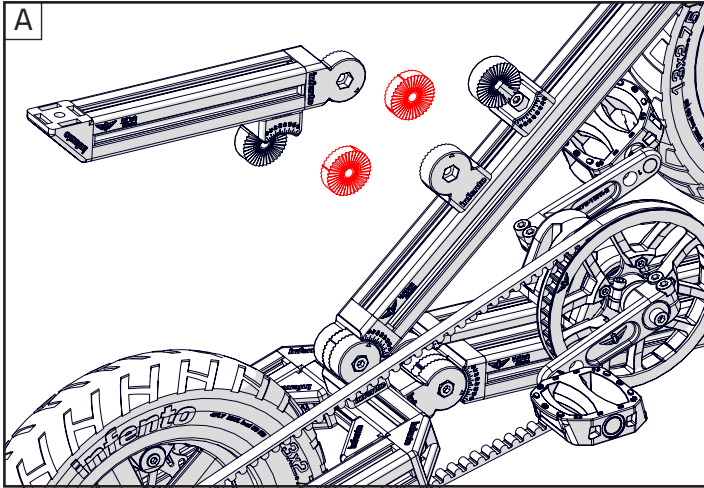

Knurled disc 1 stripe





71

ride **BULLDOG**



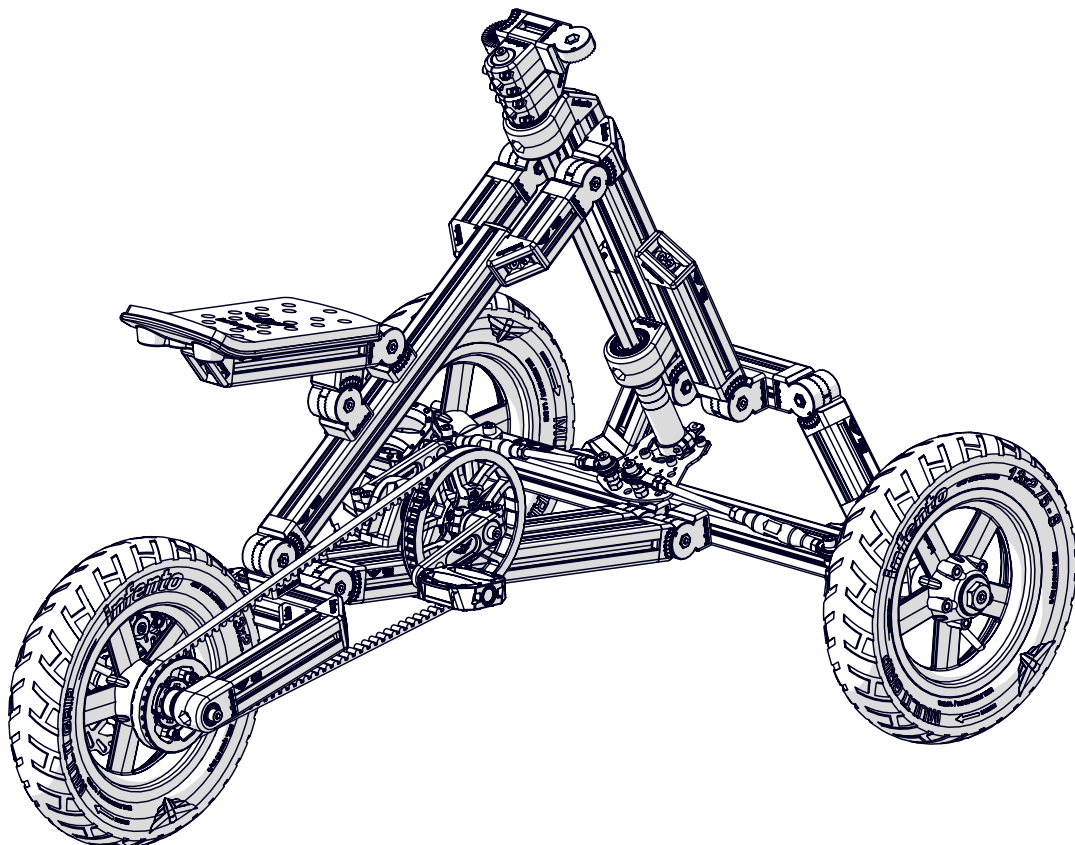
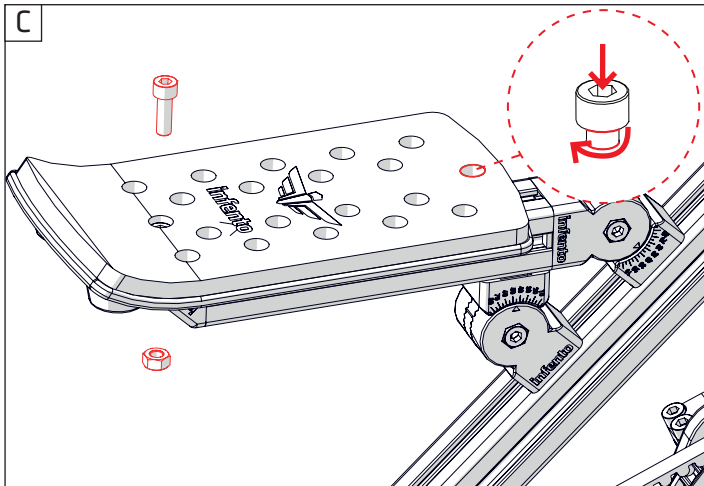
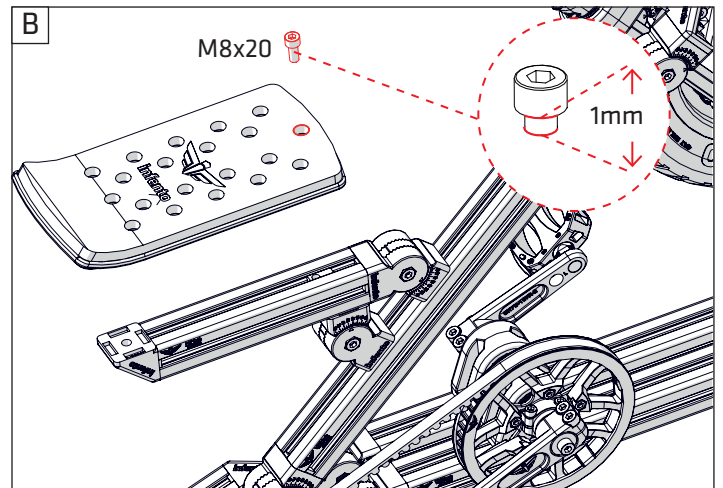
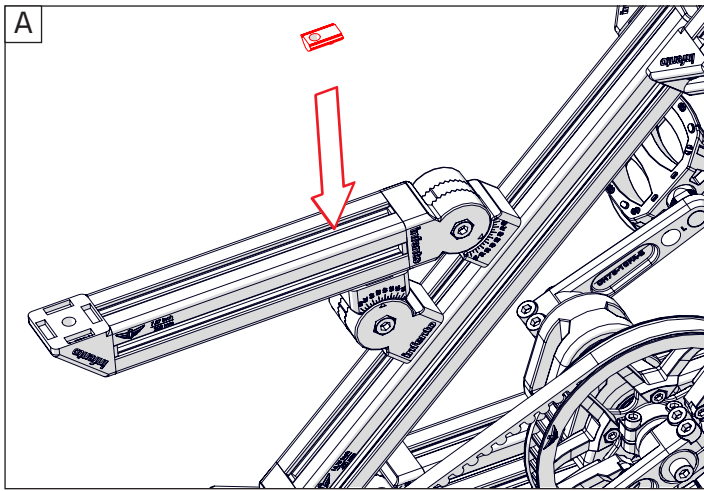

-  +  +  + 
- Nut M8 1x
- Bolt M8x25 1x
- Bolt M8x20 1x
- Profile nut short 1x



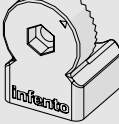

72

ride **BULLDOG**

- 
Bolt M8x25 1x
- 
Positioning block 2x
- 
Handlebar short 1x
- 
Multi angle joint 1x
- 
Axle plate 1x

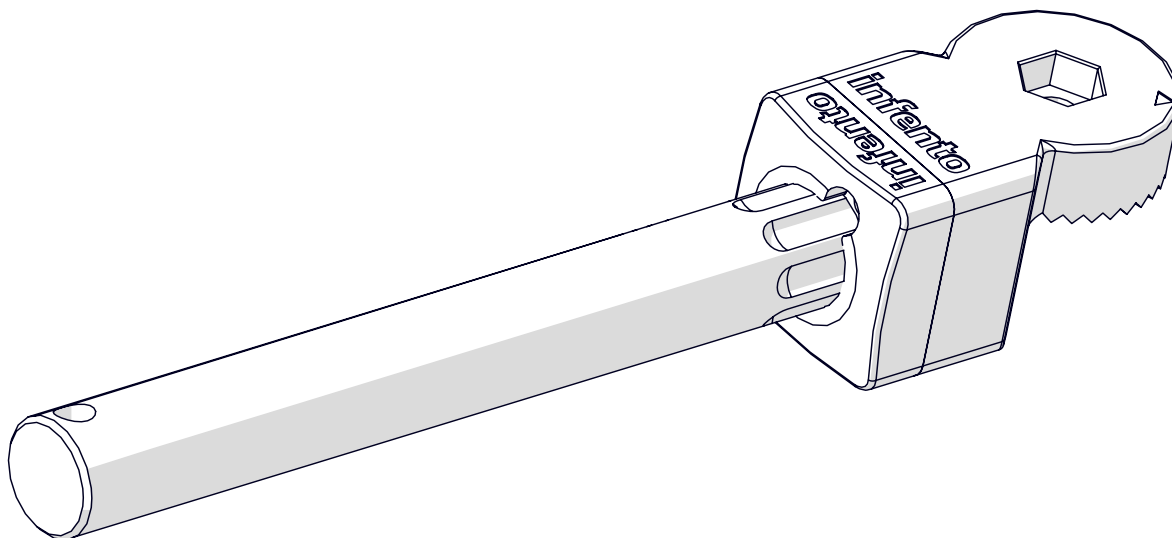
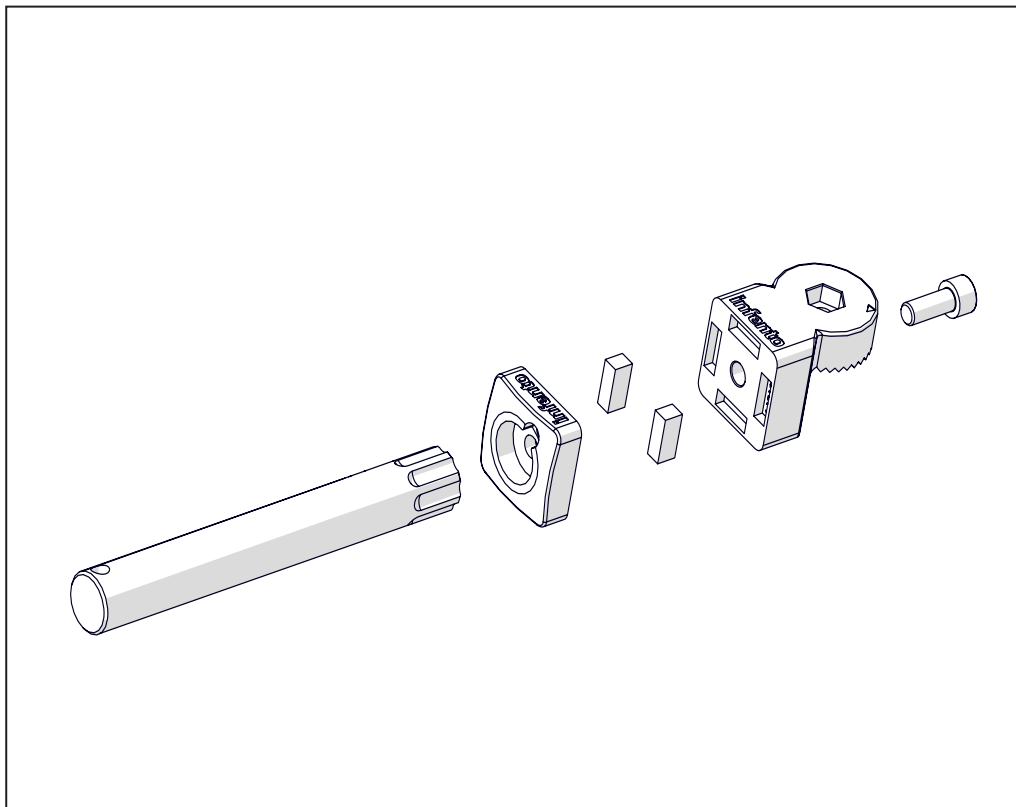



73

ride **BULLDOG**



1x

Bolt M8x35

+



1x

Locknut M8

+

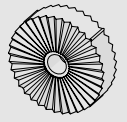

1x



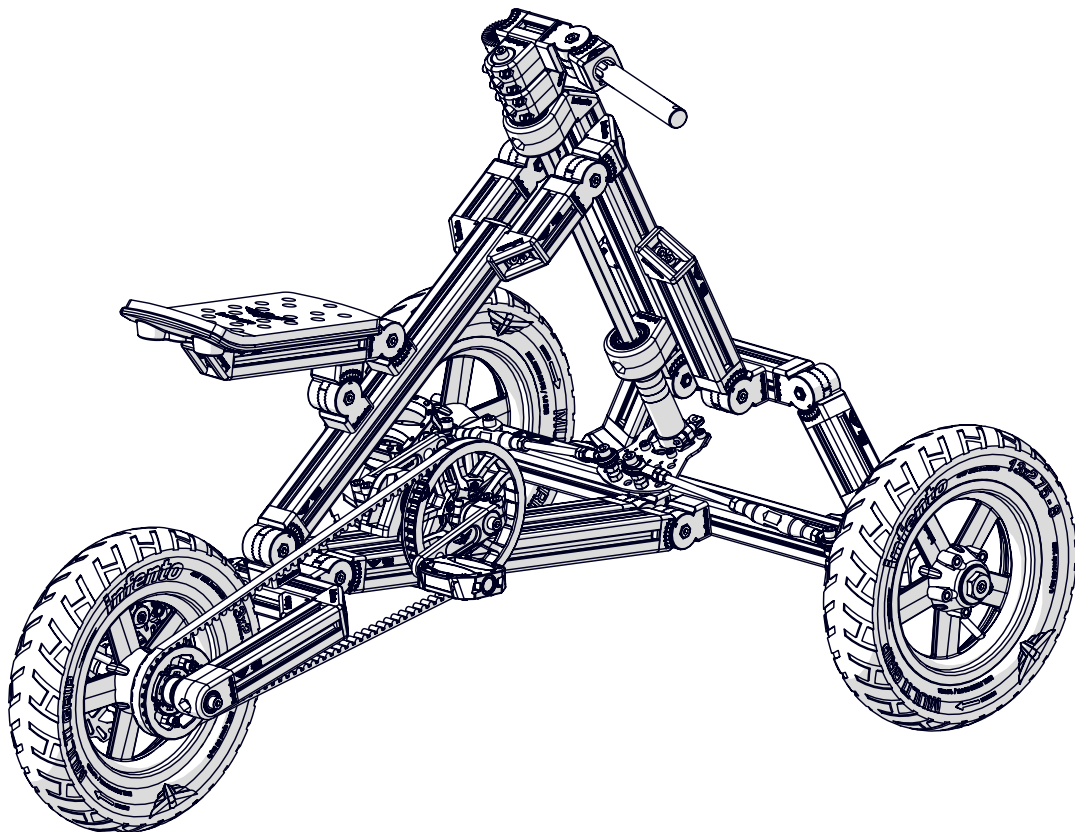
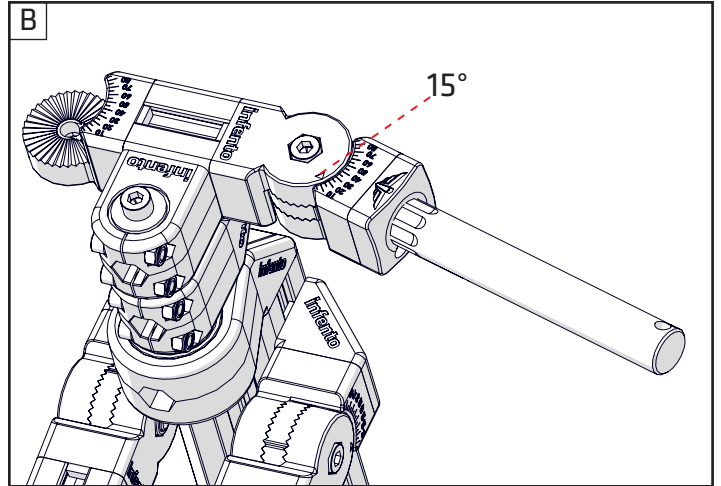
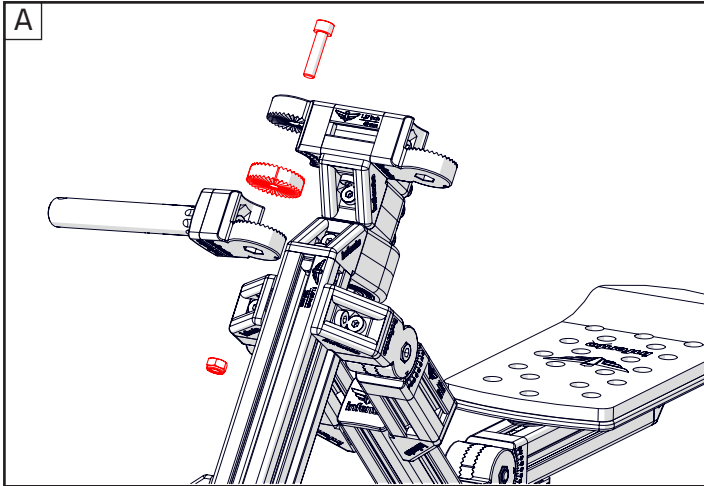

Knurled disc 1 stripe



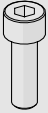

74

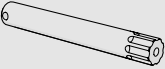
ride **BULLDOG**

- 
Bolt M8x25 1x
- 
Positioning block 2x
- 
Handlebar long 1x
- 
Multi angle joint 1x
- 
Axle plate 1x

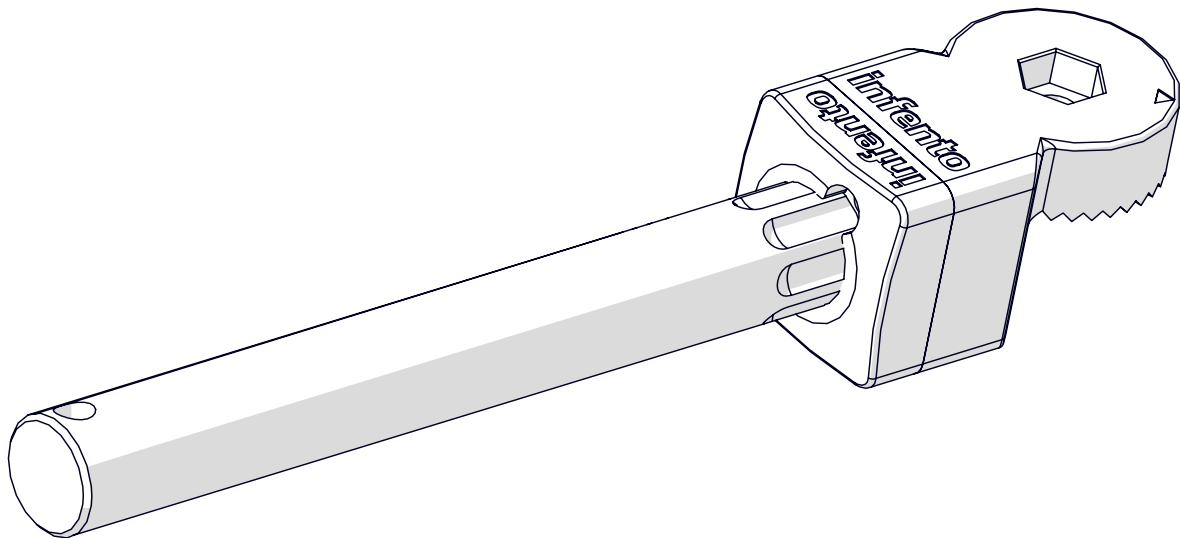
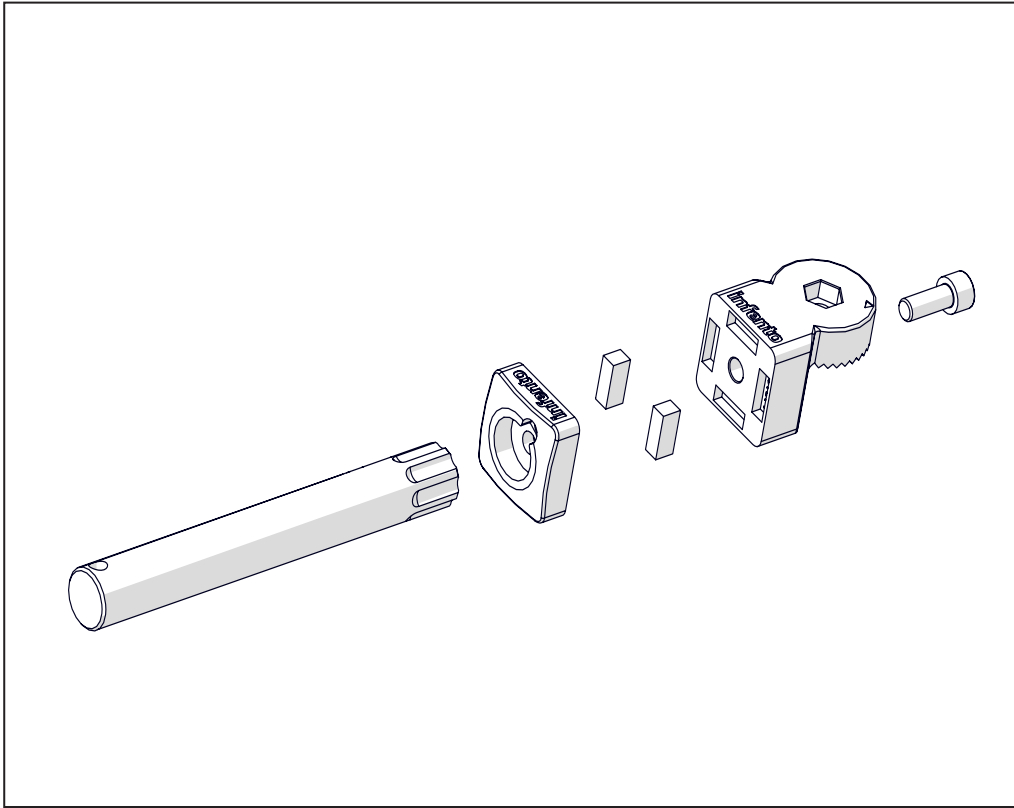



75

ride **BULLDOG**



1x

Bolt M8x35



1x

Locknut M8

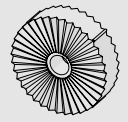

1x

Knurled disc 1 stripe

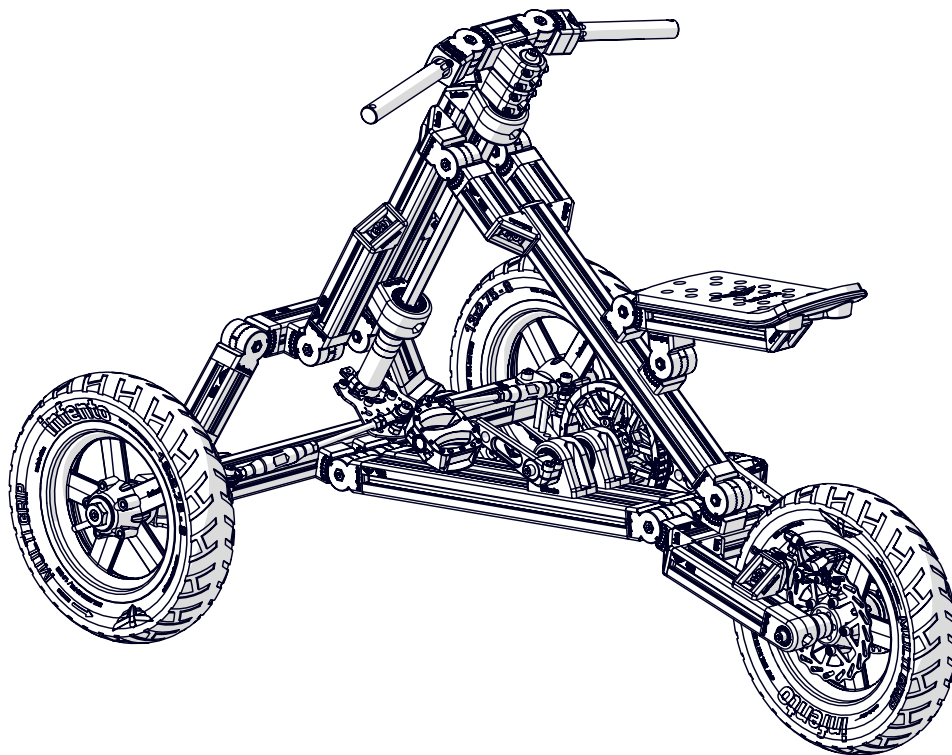
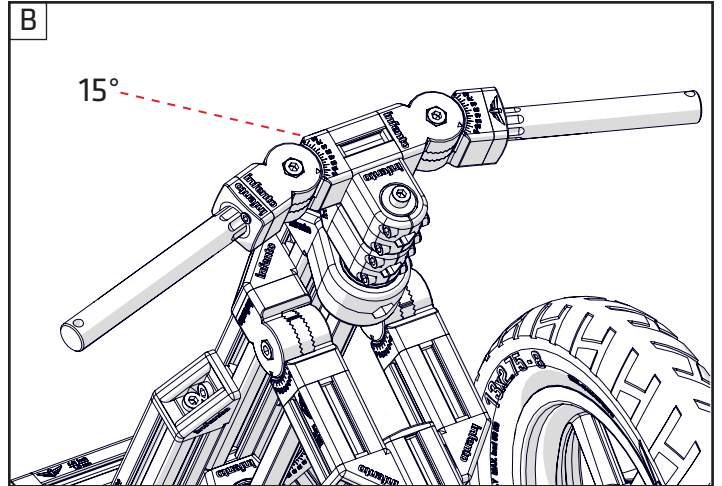
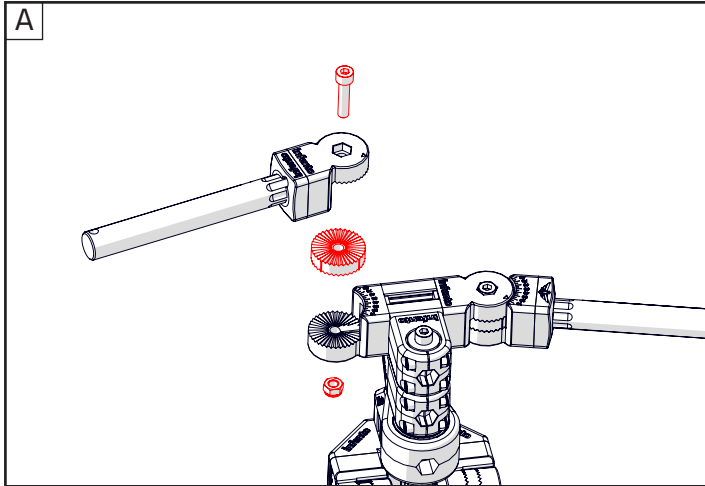



76

ride BULLDOG

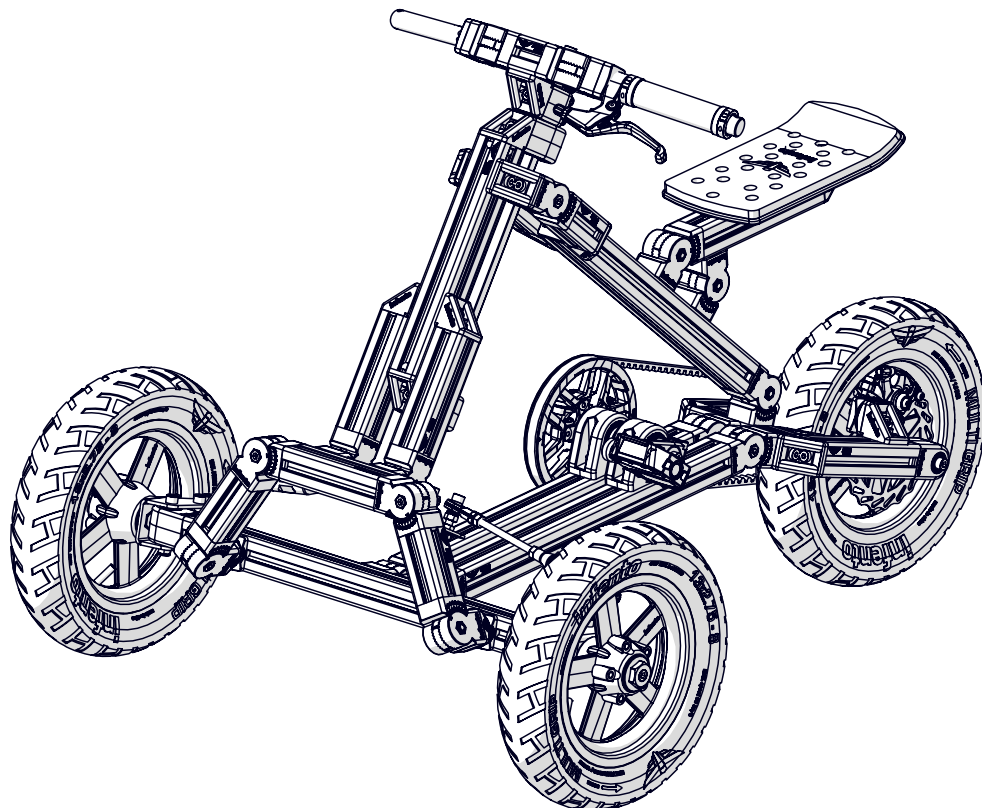
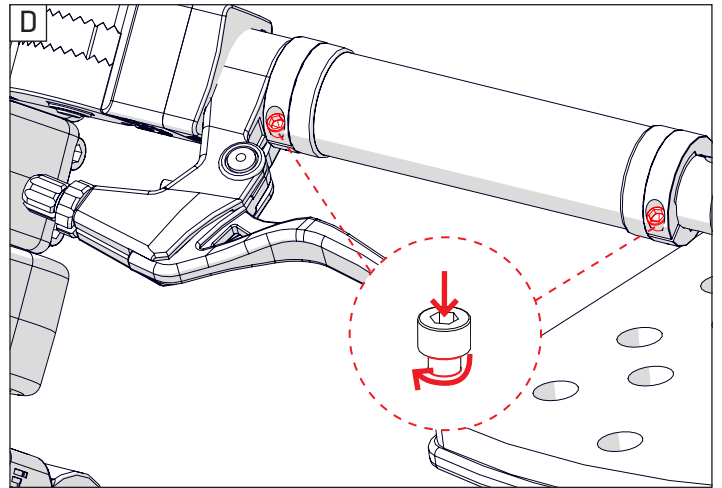
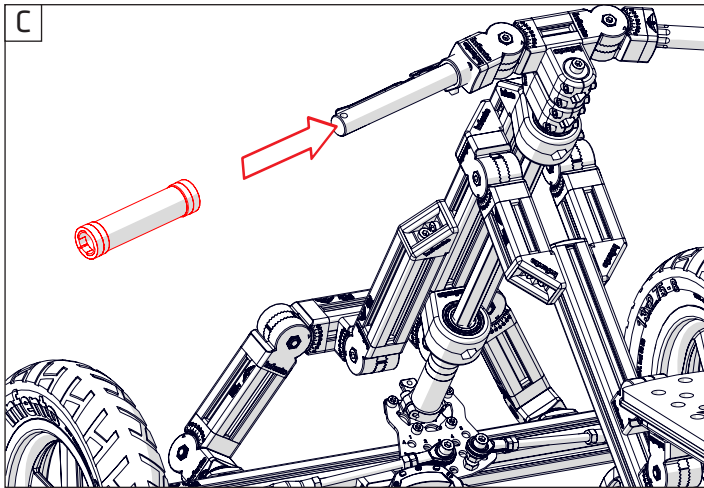
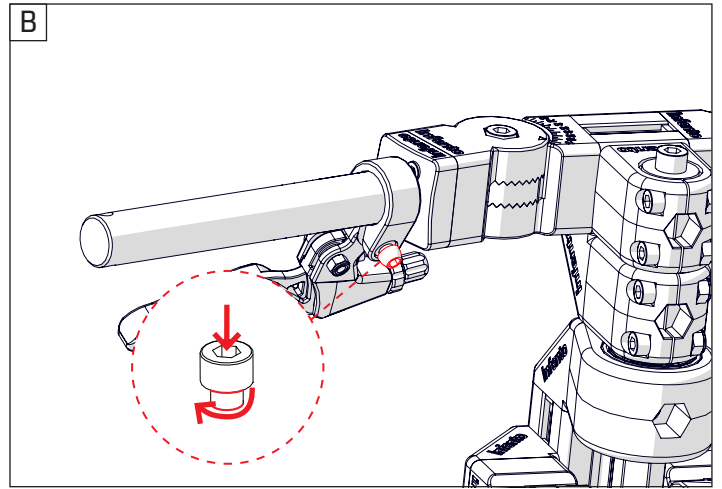
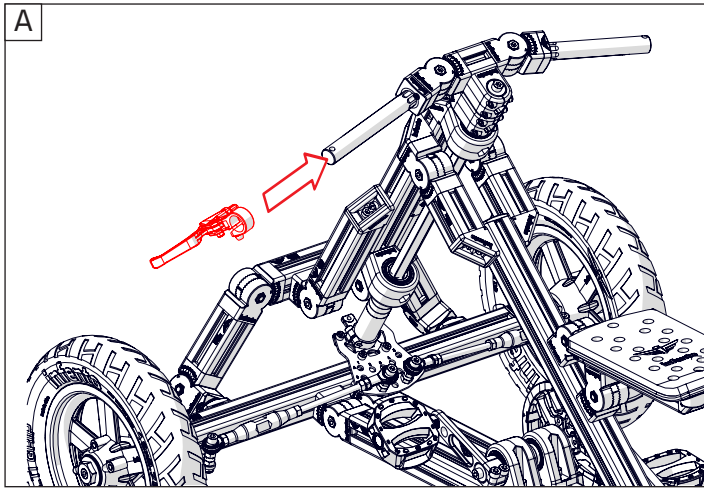
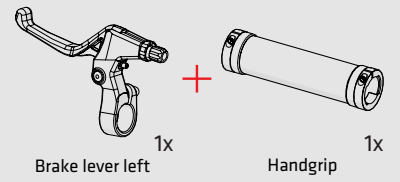



77

ride BULLDOG

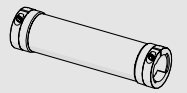

Handgrip 1x

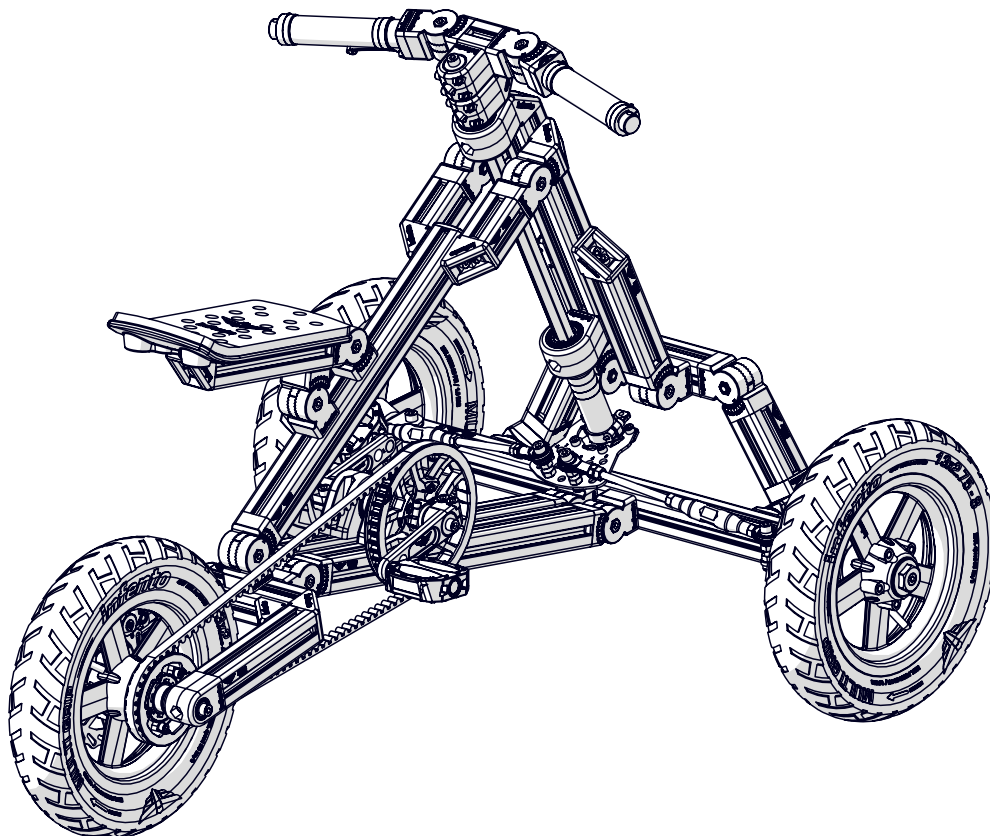
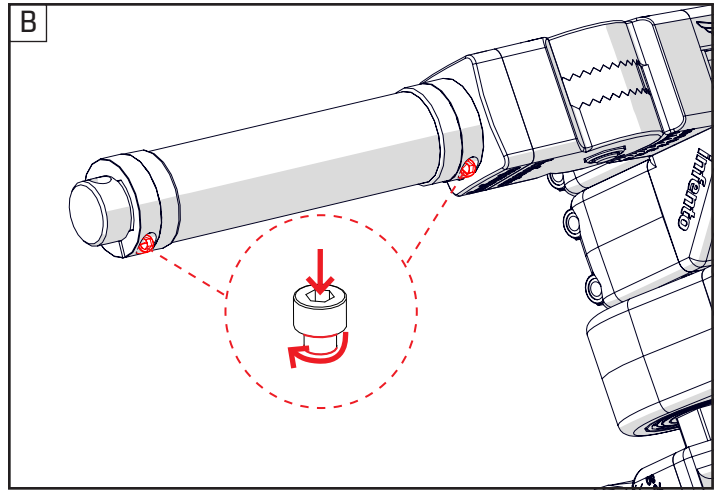
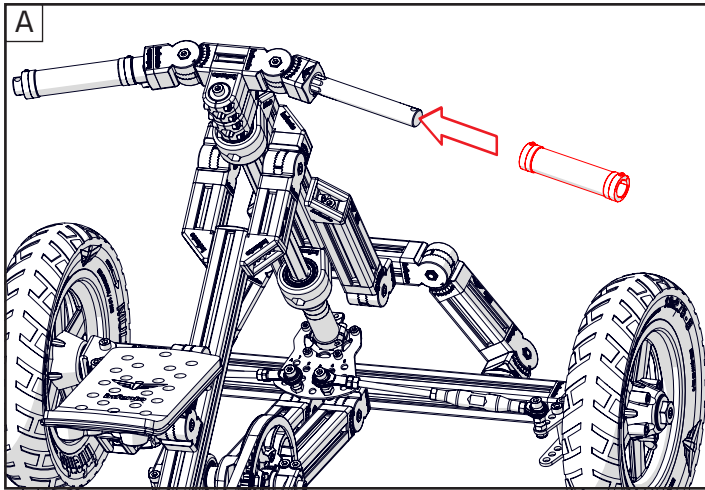



78

ride **BULLDOG**

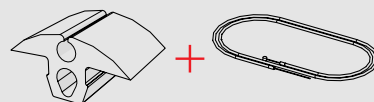

2x
Brake cable clip

1x
Brake cable
39.37 in | 1000 mm

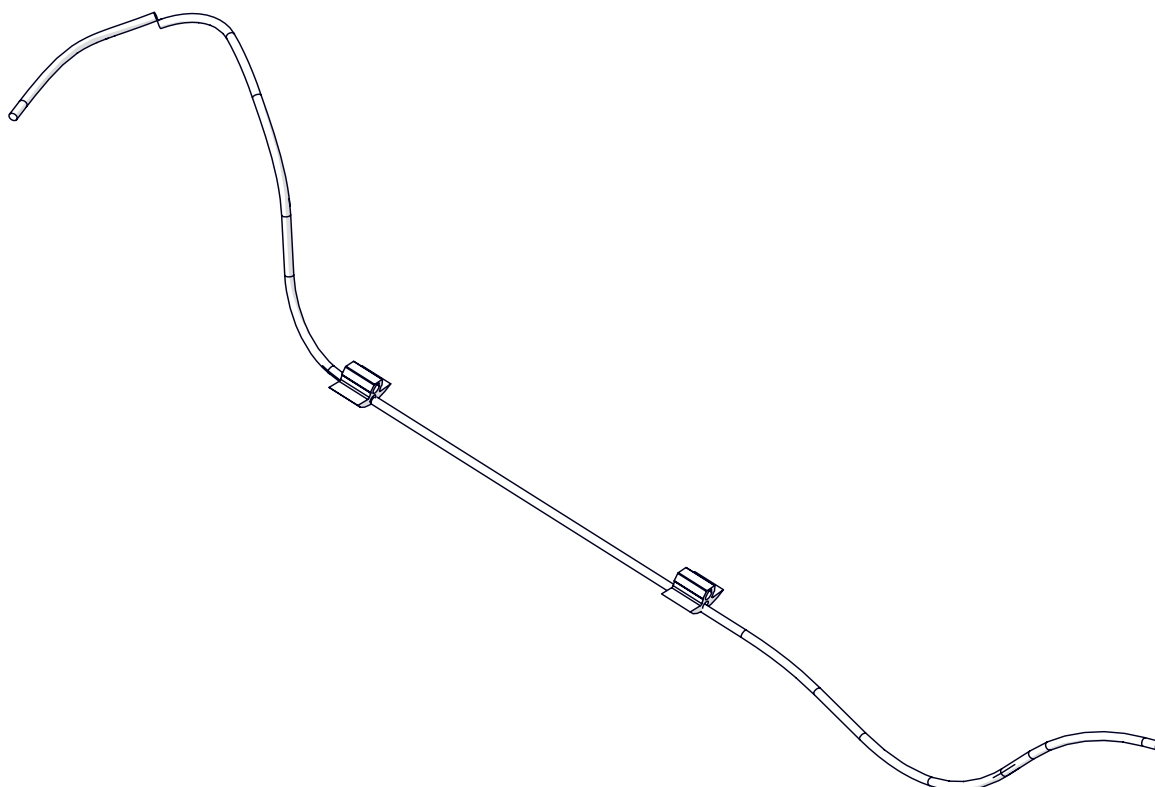
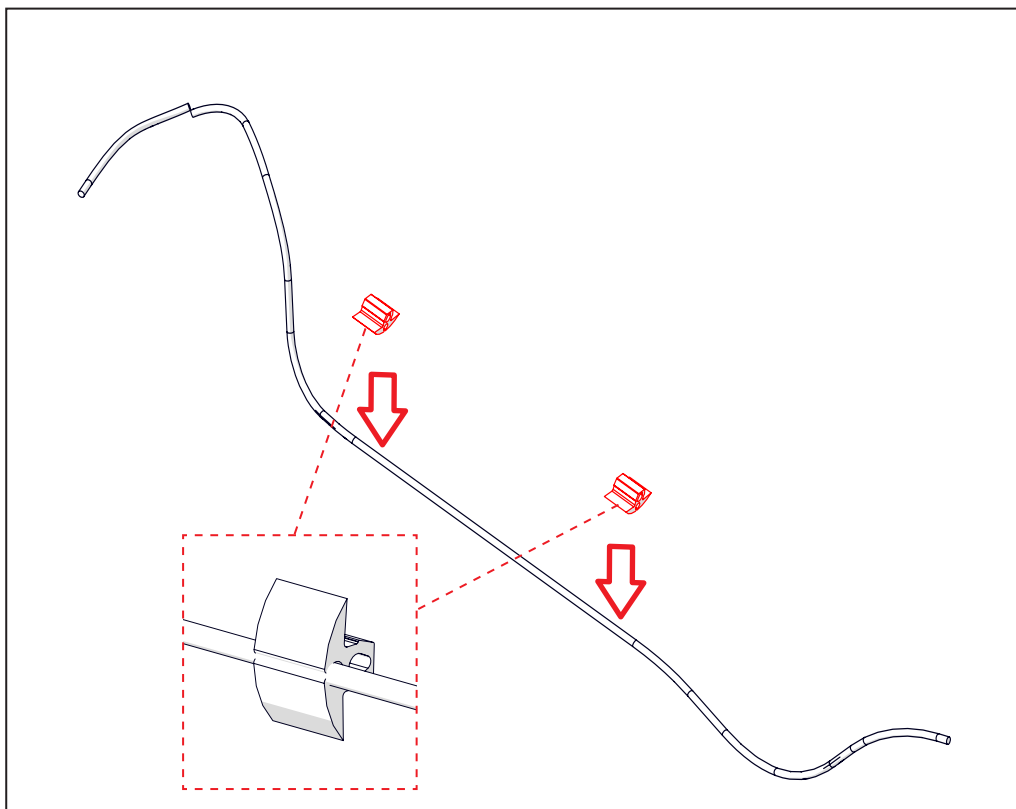



79

ride *BULLDOG*

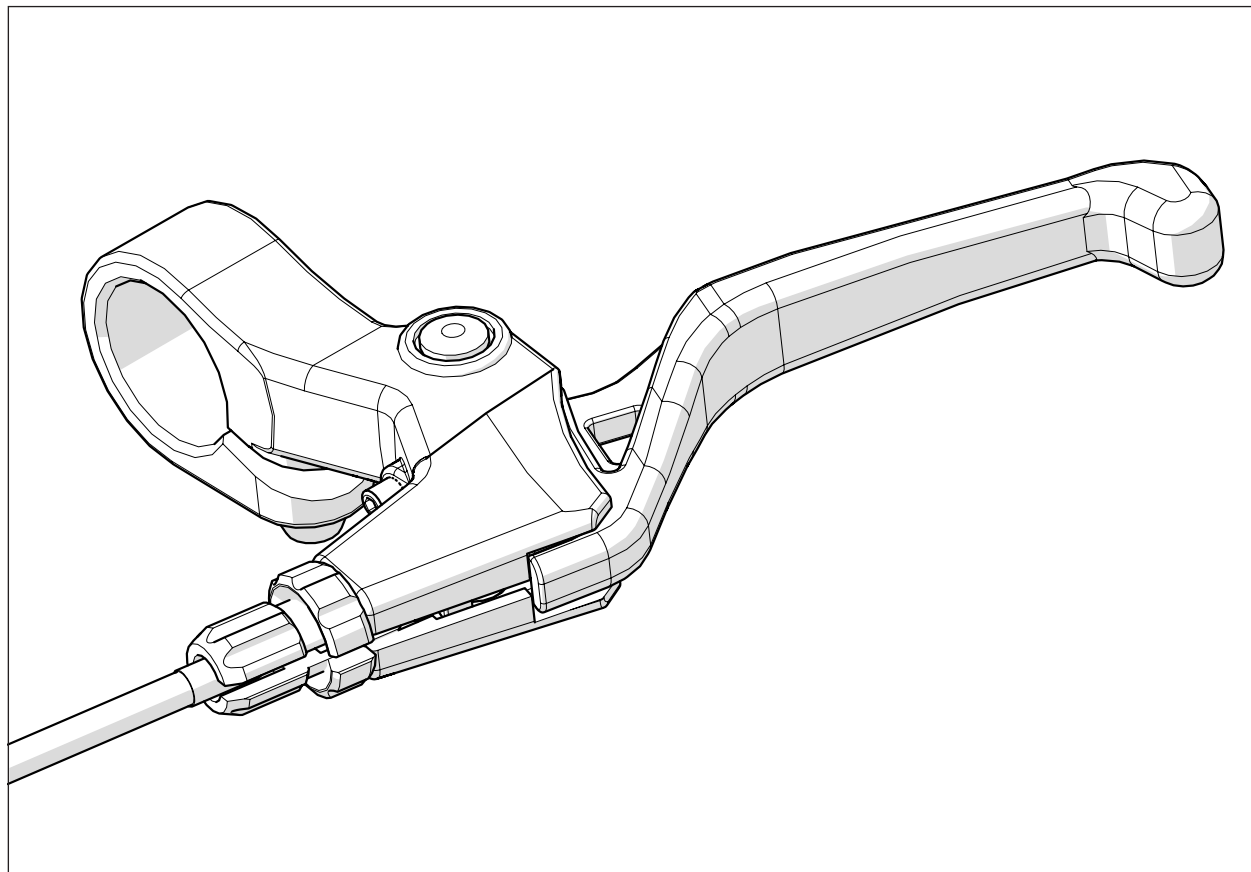
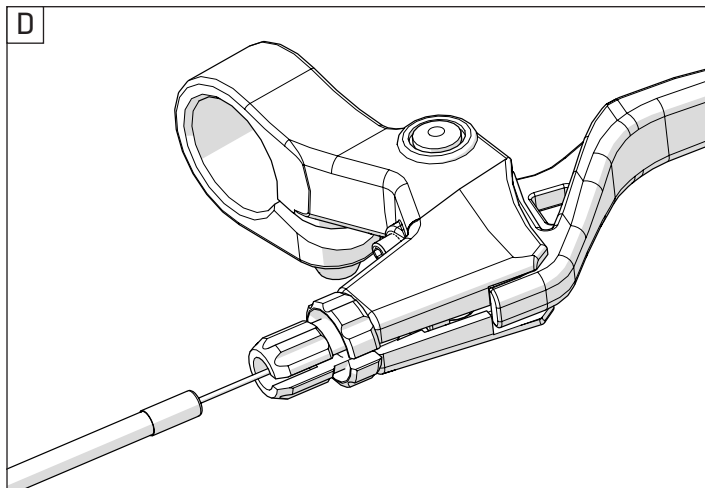
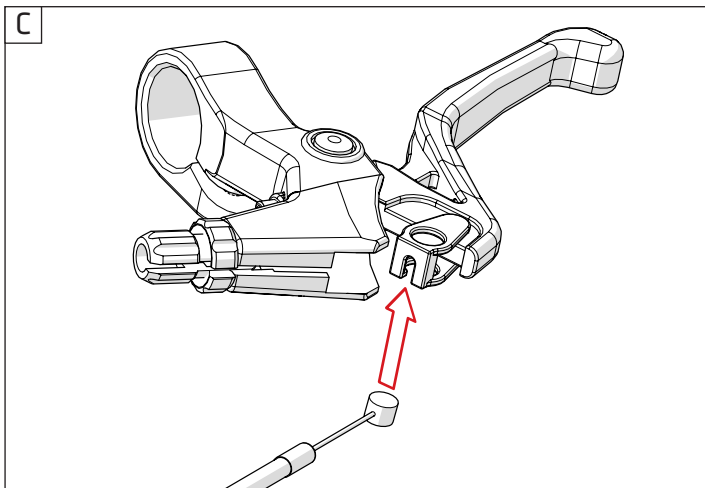
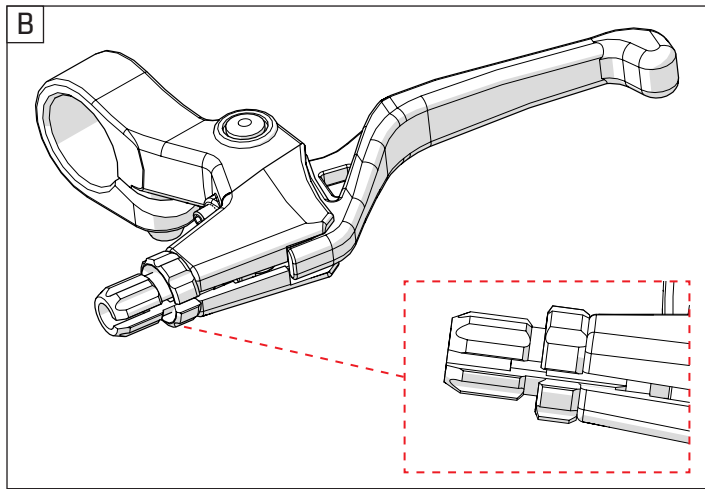
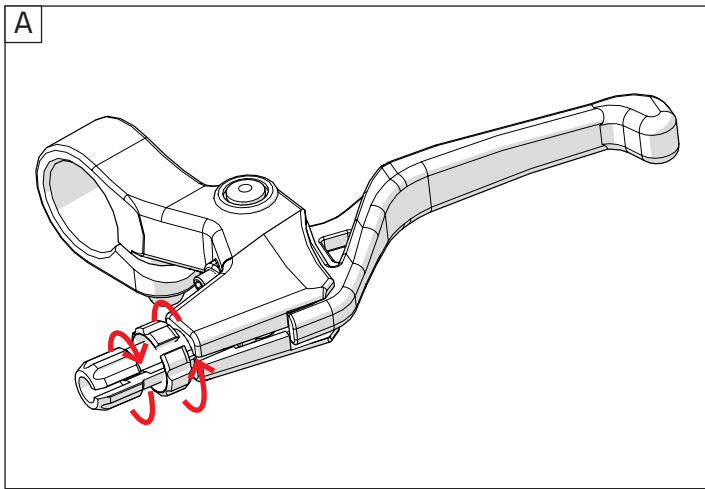



80

ride BULLDOG

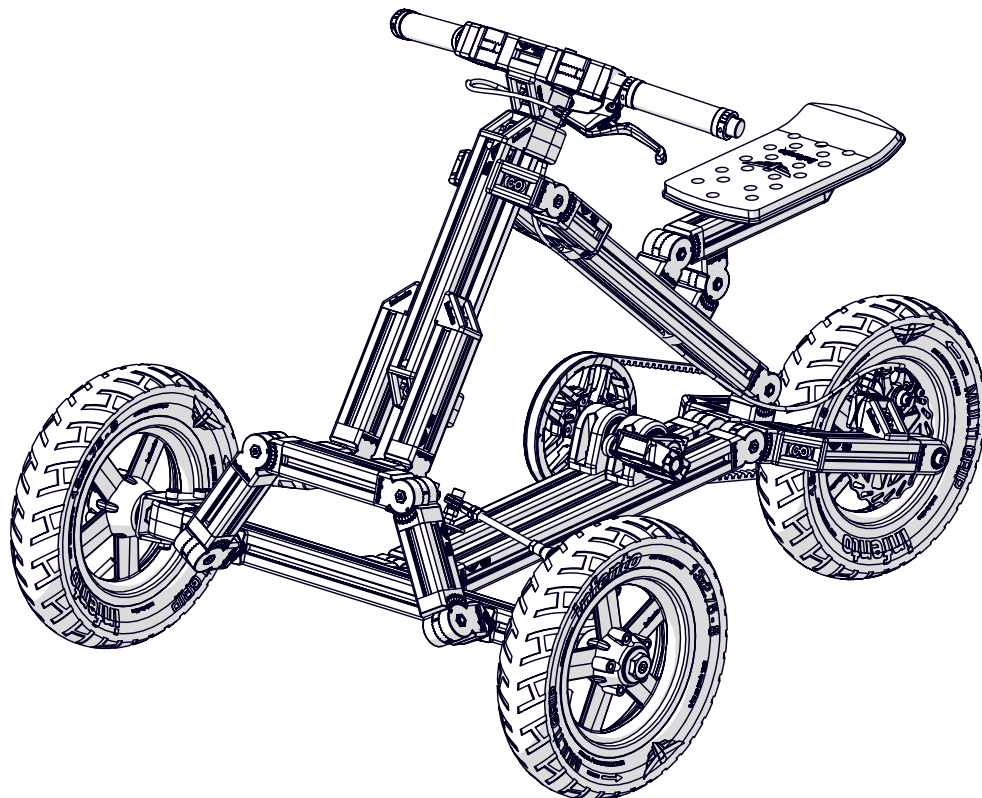
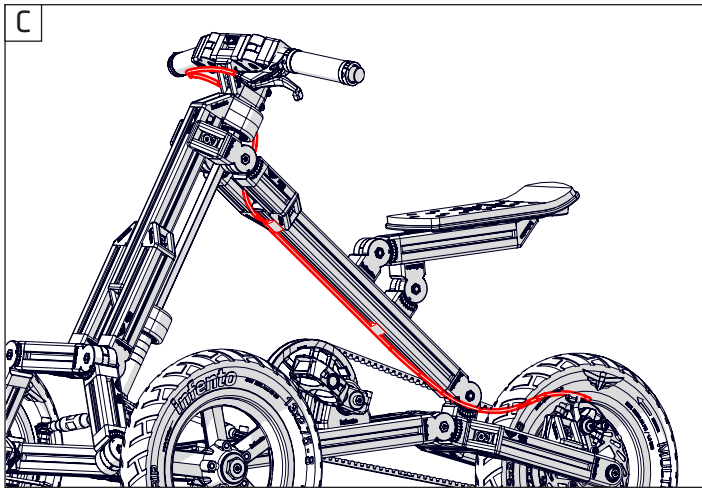
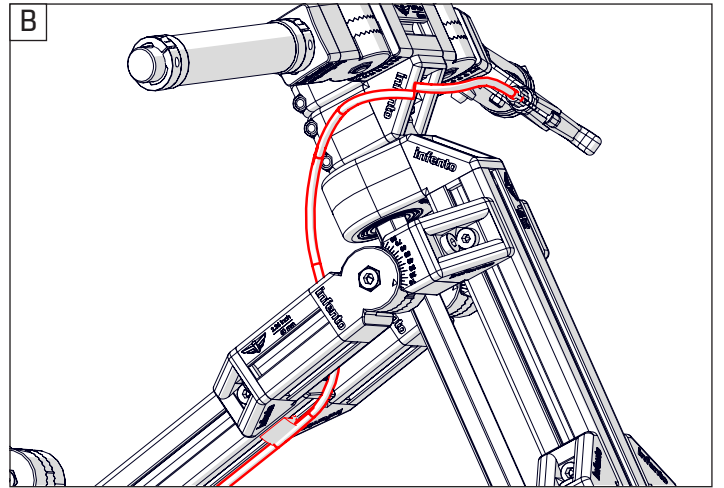
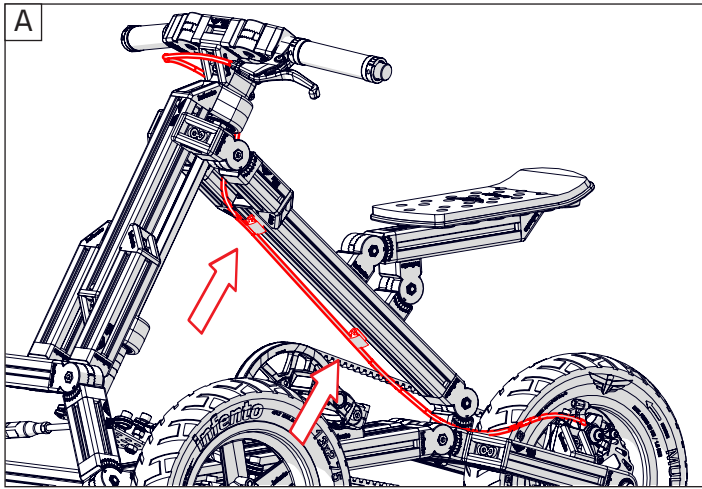



81

ride **BULLDOG**

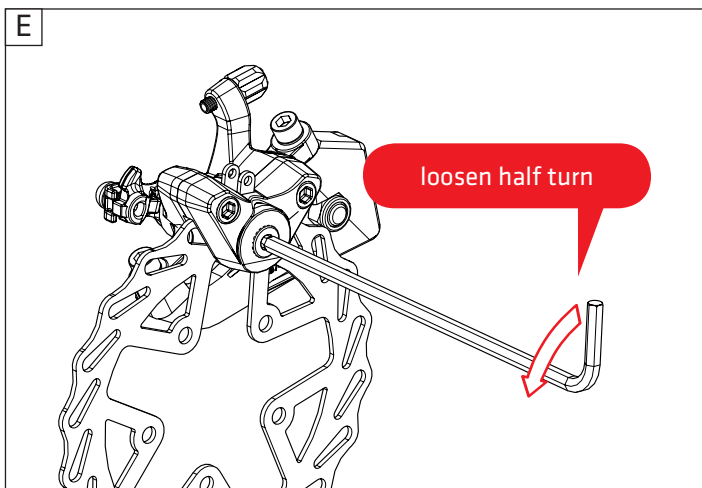
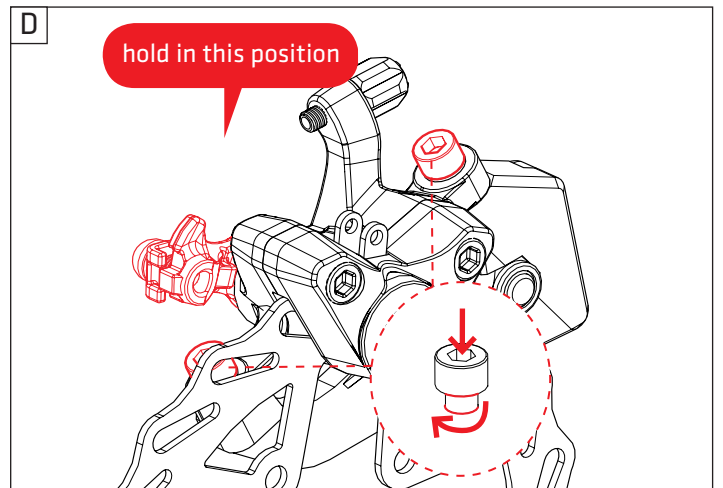
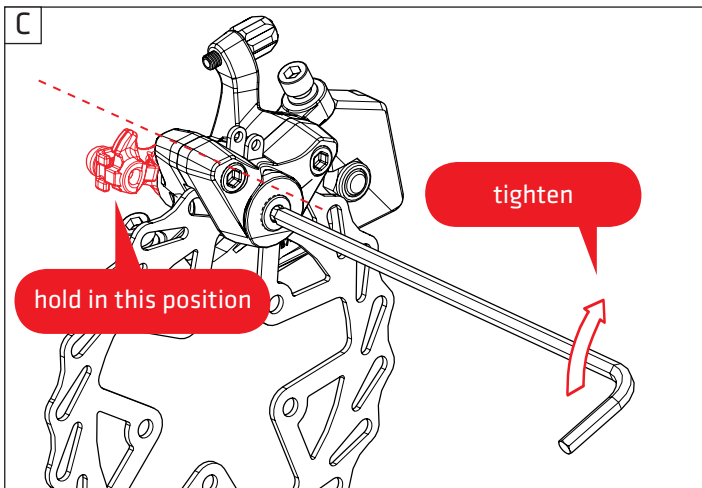
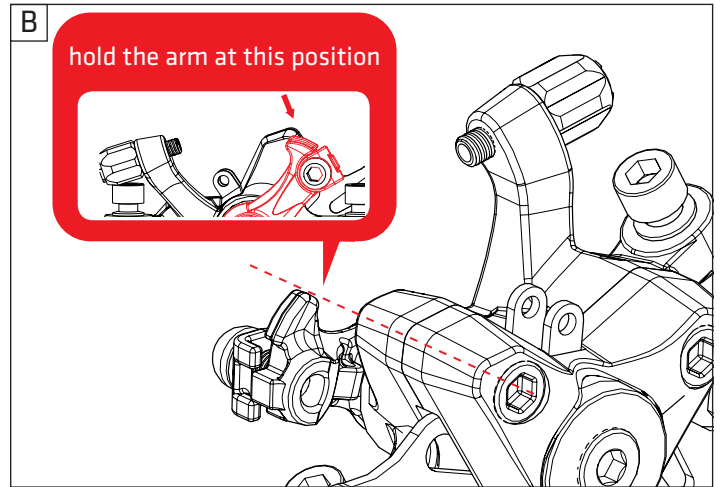
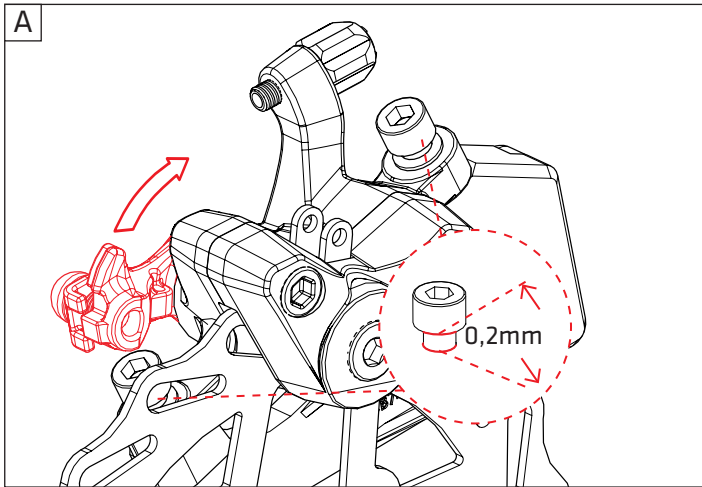



82

ride BULLDOG

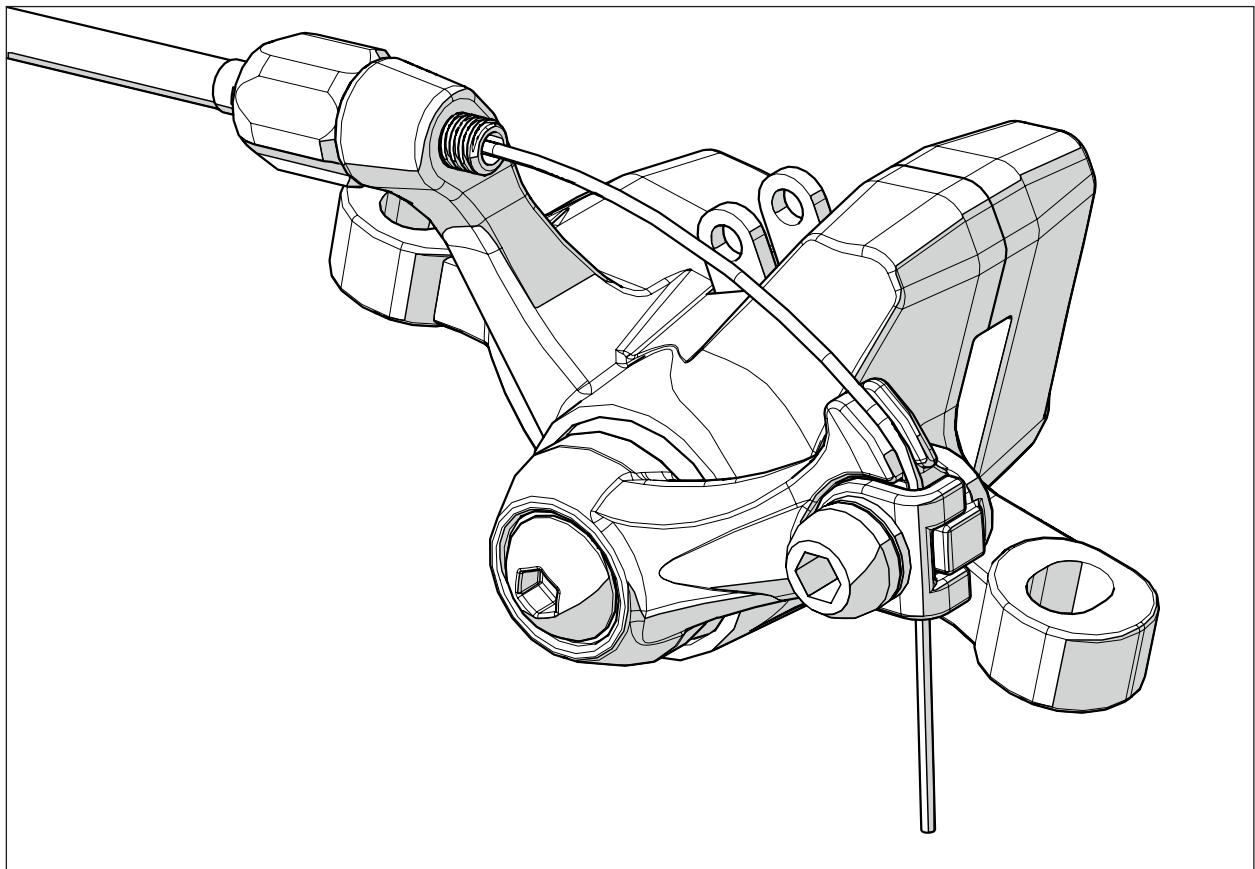
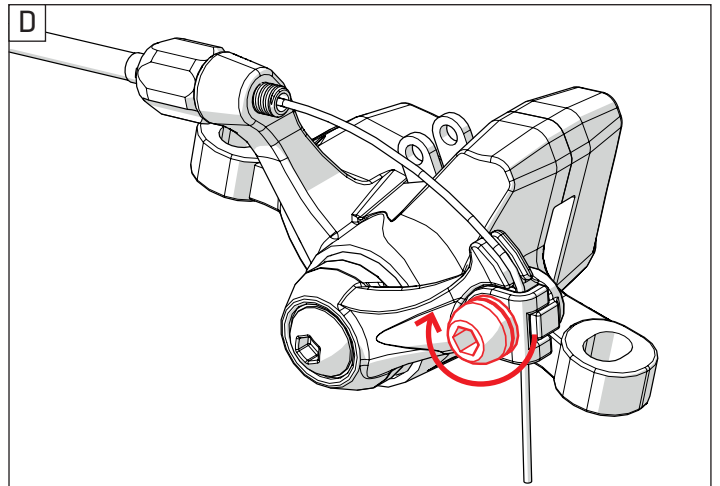
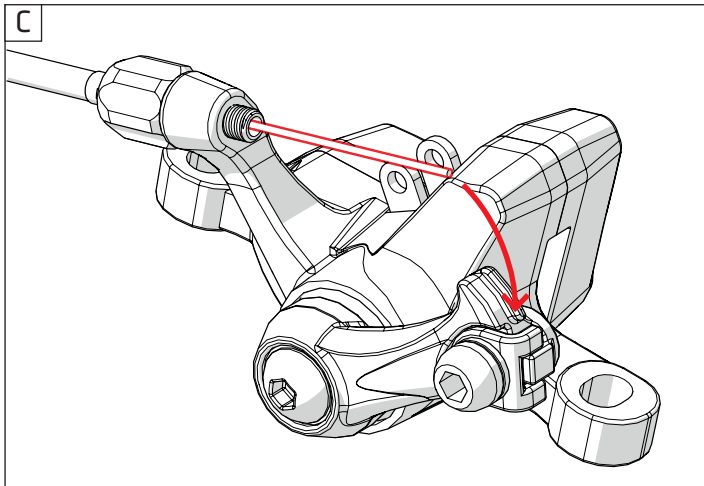
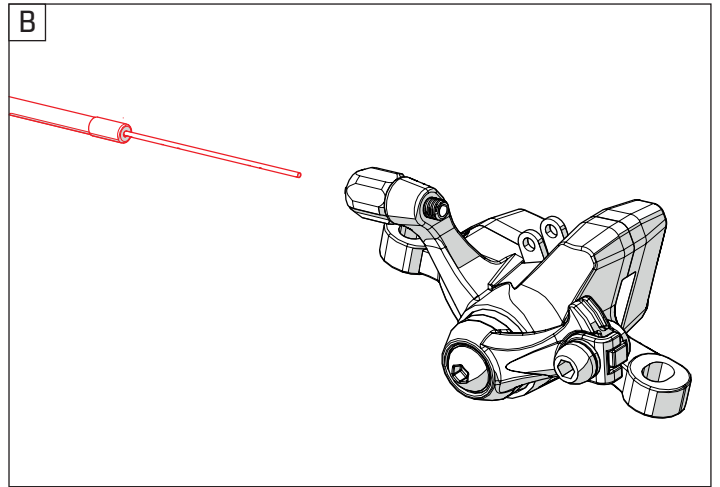
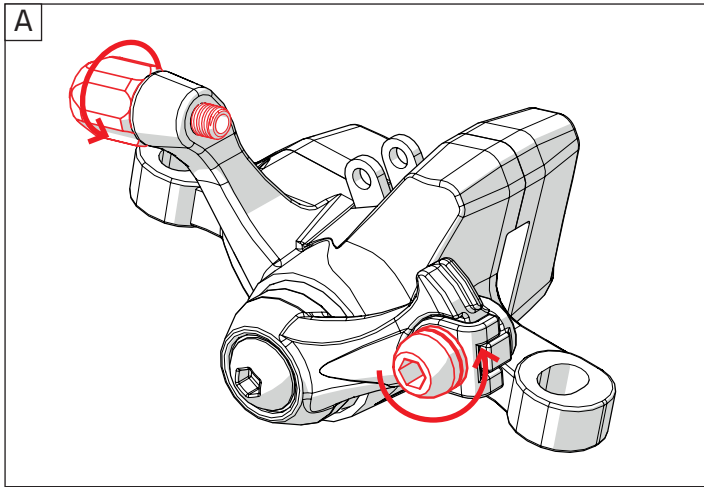



83

ride BULLDOG

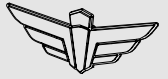

Emblem

1x

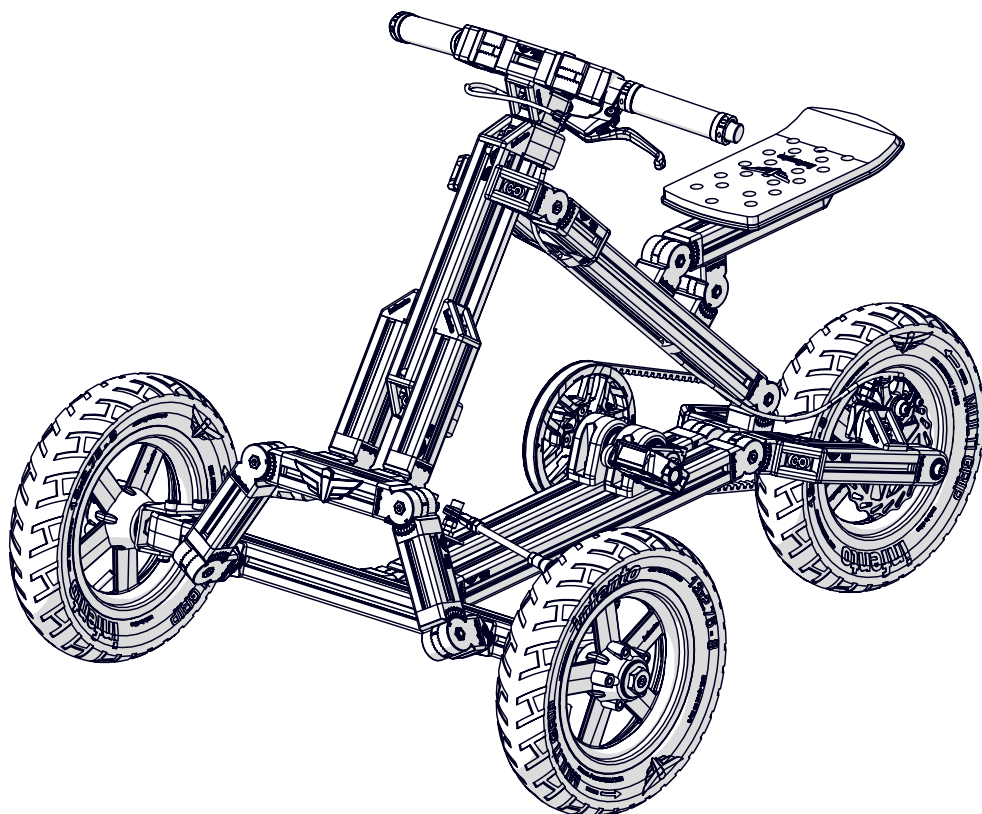
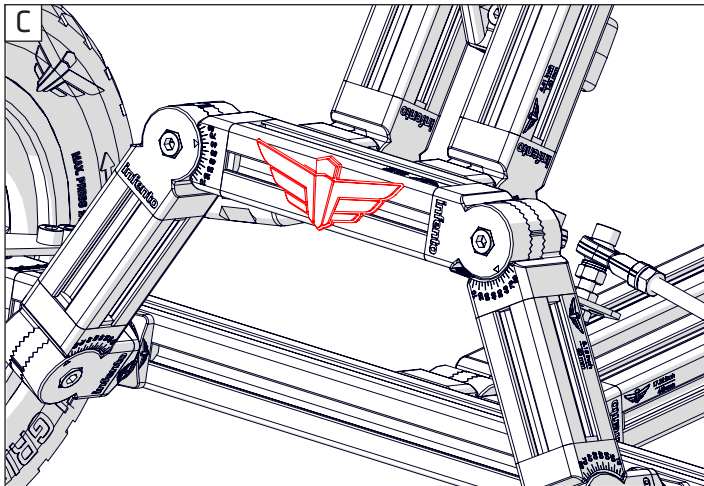
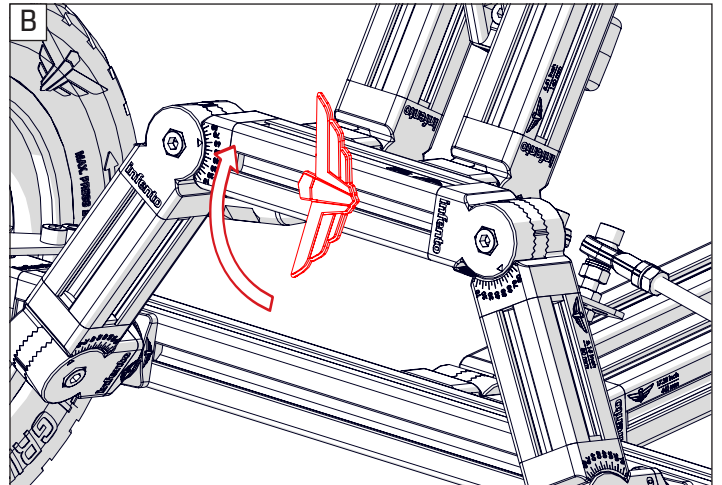
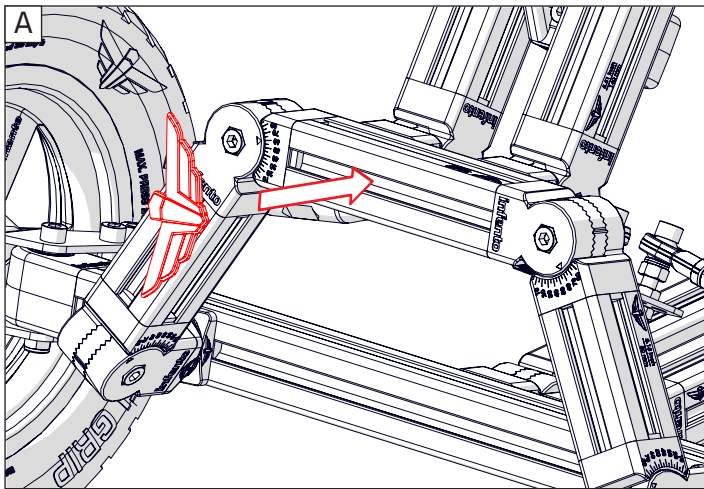

BULLDOG^{G2}



THANK YOU FOR READING ME!