

6-10
YEARS

B-TRIKE

CONSTRUCTION MANUAL



Length 120 - 140 cm / 47-55 inch
Max weight 40kg / 88 lbs
Time to build 6 hours



World's first real constructible rides



WARNING - IMPORTANT NOTICE TO PARENTS

Before you start constructing and use our product, please carefully read the following safety warning and download our manual from our website. This safety warning and manual contains important information relating to your child's safety. It is your responsibility to review this information with your child and make sure they are fully aware of all the warnings before they start riding. Failure to follow instructions and safety precautions can result in serious injury or death.

You can find a digital copy of the manual at the following web address:

www.infentorides.com

PLEASE PRINT OUT THE MANUAL AND KEEP THE MANUAL AND THIS **SAFETY WARNING** IN A SAFE LOCATION FOR FUTURE REFERENCE.

SAFETY SECTION



WARNING! PARENTAL SUPERVISION AND APPROPRIATE USE

Like any moving product, rides made from Infento parts can be dangerous if due care and attention is not paid. To reduce the risk of serious injury: use only under close adult supervision. Parents must review the following warnings and instructions with each Infento ride that is being build. It is your responsibility to review this information and make sure that all riders understand all warnings, cautions, instructions and safety topics, and assure that young riders are able to safely and responsibly use this product. Infento recommends that you periodically review and reinforce the information in this manual with younger riders, and that you inspect and maintain your child's Infento rides to insure their safety.

WARNING! RIDING ON INFENTO RIDES CAN BE A DANGEROUS ACTIVITY

Riding on Infento rides can be a dangerous activity. Certain conditions may cause the equipment to fail without fault of the manufacturer. Rides made from Infento parts can and are intended to move, and it is therefore possible to lose control, fall off and/or get into dangerous situations that no amount of care, instruction or expertise can eliminate. If such things occur you can be seriously injured or die, even when using safety equipment and other precautions. Ride at your own risk and use common sense.

WARNING! NO LIABILITY FOR CONSTRUCTED RIDES THAT DIFFER FROM OUR MANUALS

The rides that you can find in our manuals have been tested by official independent testing agencies. We will not be responsible or liable, directly or indirectly, in any way for any loss or damage of any kind incurred as a result of your decision to build constructions or rides that differ from the official rides that we show in our manuals.

ASSEMBLY – SUBSECTION

WARNING! OUR KITS CONTAIN SMALL PARTS

This package contains small parts which, before assembly, present a choking hazard to children under the age of three. Care should be taken

during unpacking and assembly to insure that all small parts and plastic bags are accounted for and kept out of the reach of children.

WARNING! TO AVOID SERIOUS INJURY:

1. Construction/assembly of a ride should always be under supervision of an adult using the Infento manual for the specific ride.
2. All fasteners (bolts and nuts) should be fully tightened.
3. It is the responsibility of the adult who assembles this bicycle to properly install all parts included in the factory sealed shipping carton and to make the adjustments to the functional parts such as handle bar and seat and chain when necessary.

USE – SUBSECTION

WARNING! TO AVOID SERIOUS INJURY:

1. Continuous adult supervision is required.
2. Only ride constructed rides that have been built according to the instructions given in the official Infento manual.
3. Never exceed the maximum weight. You can find the maximum weight for every specific ride in our manual.
4. Always check the manual to see the minimum and maximum age as well as the minimum and maximum length for every specific ride.
5. Always wear safety equipment such as a helmet, knee pads and elbow pads. We recommend riders always wear a properly fitted helmet that complies with local or national guidelines or laws. Keep chinstrap of helmet securely buckled.
6. Always wear closed toed shoes (lace-up shoes with rubber soles), never ride barefooted or in sandals, and keep shoe laces tied and out of the way of the wheels.
7. Avoid streets and surfaces with water, sand, gravel, dirt, leaves, and other debris. Wet weather impairs traction, braking and visibility.
8. Excessive exposure to sunlight, temperatures below 0 degrees Celsius, water, sand, gravel, dirt, leaves, and other debris can damage, shrink, expand or weaken parts. Keep your ride in a dry environment with proper heating.
9. Avoid sharp bumps, drainage grates and sudden surface changes. Your Infento ride may suddenly stop.
10. Ride on smooth, paved surfaces away from

motor vehicles. Wet, slick or uneven and rough surfaces may impair traction and contribute to possible accidents.

11. Never risk damaging surfaces, such as carpet or flooring, by use of an Infento ride indoors.
 12. Never use near motor vehicles, streets, roadways, alleys, swimming pool areas, hills, steps, sloped driveways, inclines and public highways.
 13. Watch out for pedestrians, skaters, skateboards, scooters, bikes, children or animals who may enter your path, and respect the rights and property of others.
 14. Avoid excessive speed associated with downhill rides.
 15. Do not use at night or in periods with reduced visibility.
 16. Before every use, please make sure that the complete ride and all joints have been assembled tightly, as with use, joints may wear out.
 17. Before using your Infento ride, please check that the screws are tightened securely.
 18. It's your own responsibility if you modify the product other than manufacturer's instructions.
 19. Maintain a hold on the handlebars at all times.
 20. Brake will get hot from continuous use. Do not touch after braking.
 21. Periodically check hardware and tighten if necessary. Replace worn or broken parts immediately.
 22. Skill is required to avoid falls or collision causing injury to the user and third parties.
 23. Check operation of breaks every time before bicycle is ridden.
 24. Check local laws before you start with riding.
 25. Never tow wagons, other vehicles, or children on skates or skateboards.
 26. Make certain that anyone who uses an Infento ride has been fully instructed in its operation.
 27. Instruct your child on how to use the breaks.
 28. Do not perform stunts.
 29. Never use headphones or a cell phone when riding.
 30. Only one rider at a time on an Infento ride.
 31. Do not allow children to stand on the product at any time.
- FAILURE TO USE COMMON SENSE AND HEED THE ABOVE WARNINGS INCREASES RISK OF SERIOUS INJURY. USE WITH APPROPRIATE CAUTION AND SERIOUS ATTENTION TO SAFE OPERATION.**

SAFETY SECTION



OUR KITS CONTAIN SMALL PARTS

This package contains small parts which, before assembly, present a choking hazard to children under the age of three. Care should be taken during unpacking and assembly to insure that all small parts and plastic bags are accounted for and kept out of the reach of children.

QUESTIONS OR SUPPORT NEEDED?

You can mail us all your questions at:
support@infentorides.com
and our team will reply you as soon as possible.



MAINTENANCE | INSTRUCTION



1. Oil or grease moving parts periodically.
2. Check nuts and bolts often and tighten if necessary.
3. Any parts showing evidence or wear should be replaced immediately.
4. Follow closely the assembly instructions pertaining to the proper adjustments of parts
5. Periodically check the brake system for proper function
6. Periodically check the steering mechanism for proper function
7. Check the air pressure in the tires to be the amount specified in the manual
8. Periodically check the bicycle's tooth belt to be sure that it is not too loose which could allow the chain to slip off the sprockets.

RECOMMENDED TOOLS



4 x Allen key
3, 4, 5, 6 mm



1 x Tapeline



1 x T-handle
for Allen key

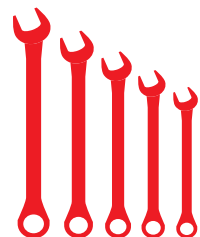

5 x Wrench
10, 13, 14, 15, 19 mm



1

ride **B-TRIKE**

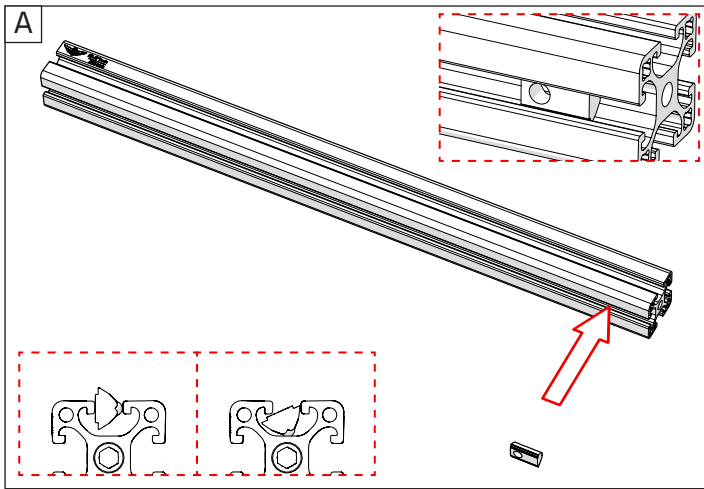
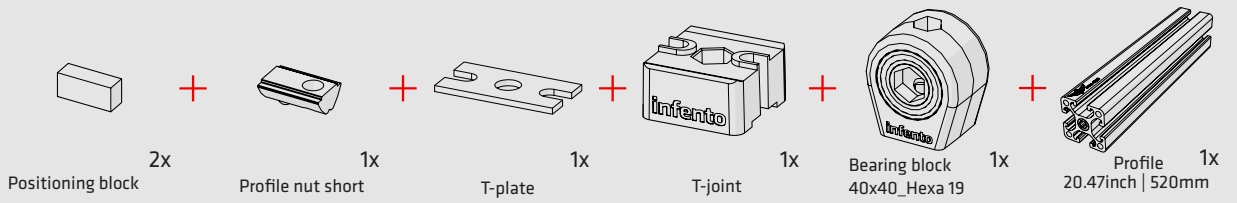

First, get all required materials stated here and then follow the instructions.

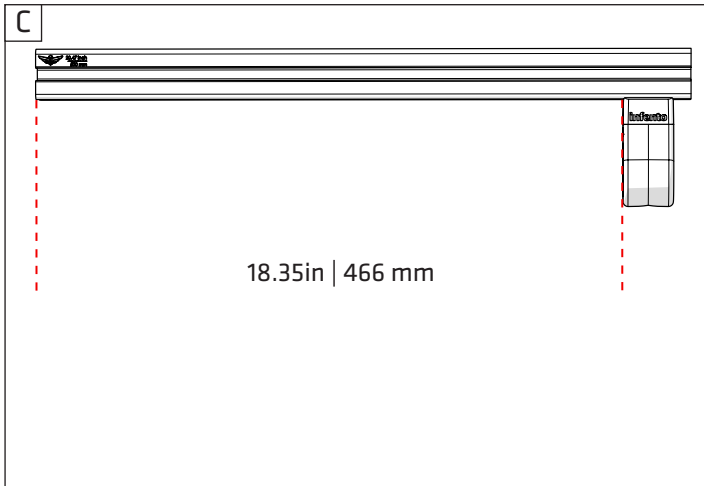
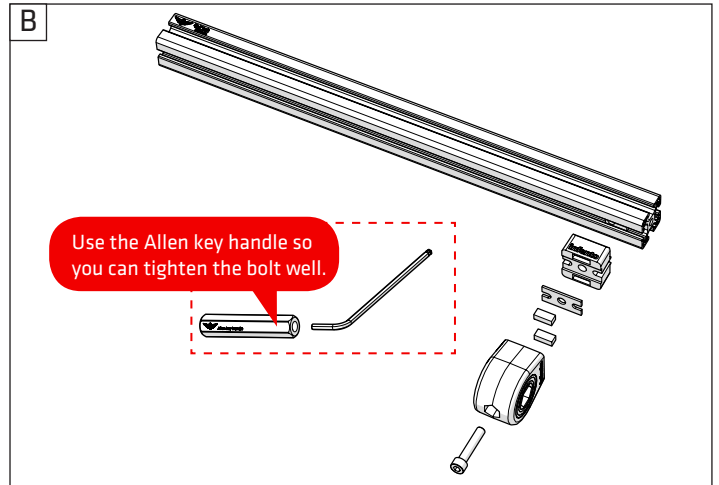
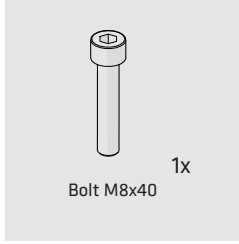

TIP!
It is best to tighten the bolt in such a way that you can still move the block and easily determine the right position with a tape measure. After that, you can then tighten the block further and you verify whether the size is correct.

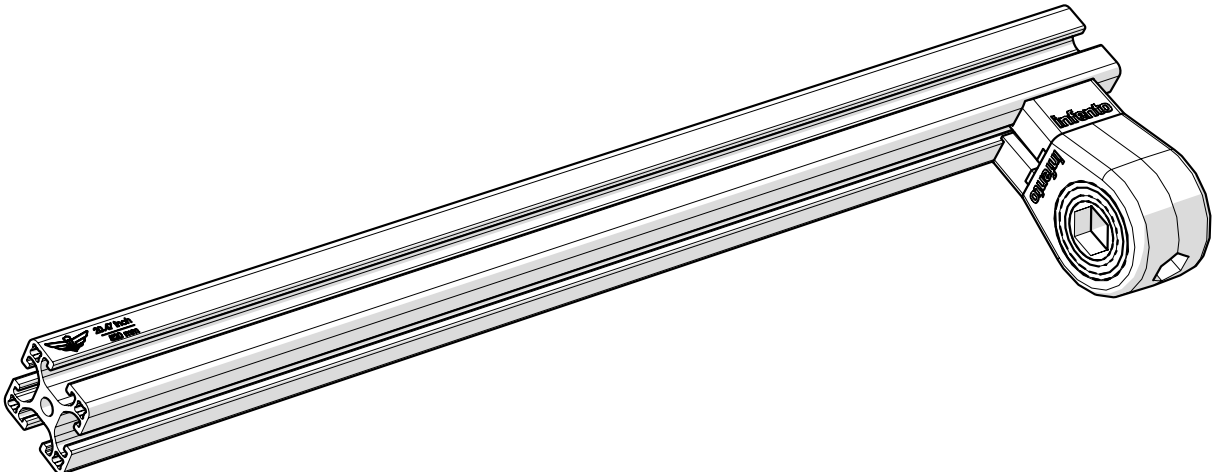

TOP 3 REQUIREMENTS MAKING A GREAT INFENTO EXPERIENCE:



1

Tighten bolts with full force (15Nm) to prevent them from coming loose.

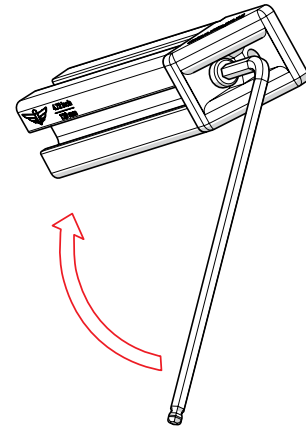

2

Constructing and playing always under supervision of an adult.



3

Check frequently if all parts are still firmly tightened and function properly.





2

ride **B-TRIKE**

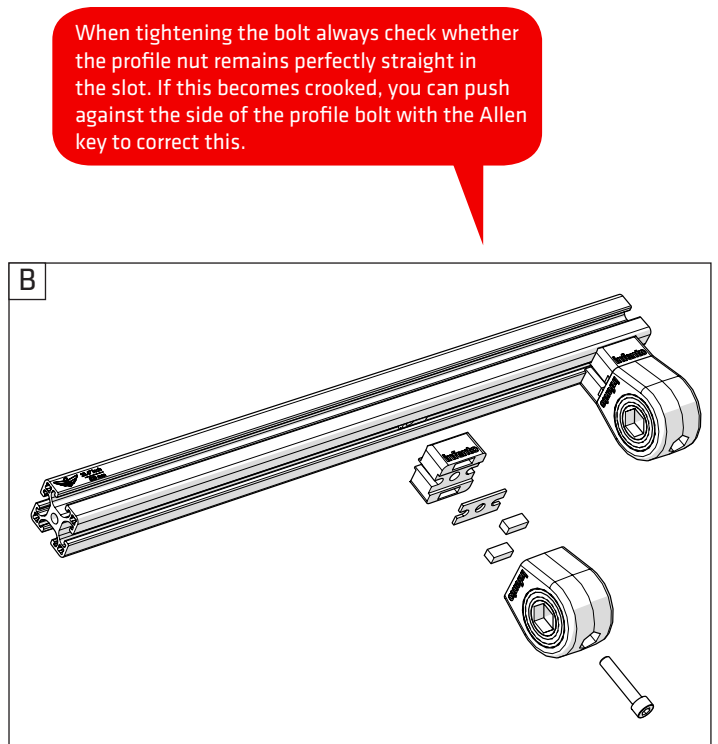
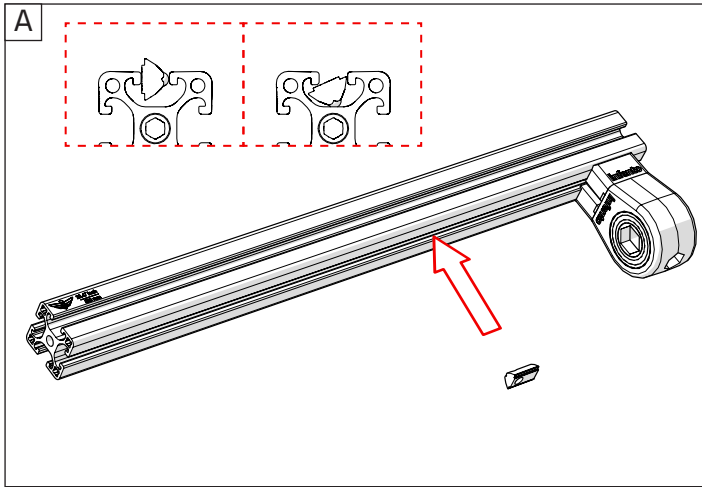
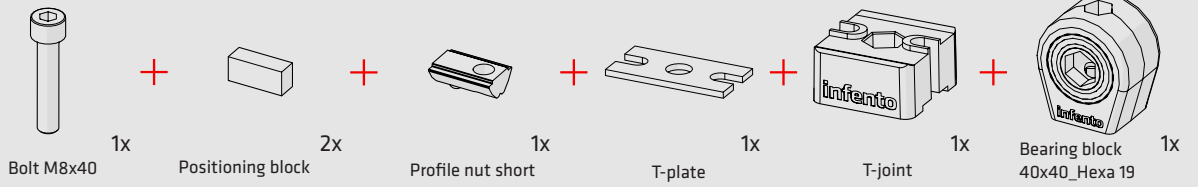

When tightening the bolt always check whether the profile nut remains perfectly straight in the slot. If this becomes crooked, you can push against the side of the profile bolt with the Allen key to correct this.

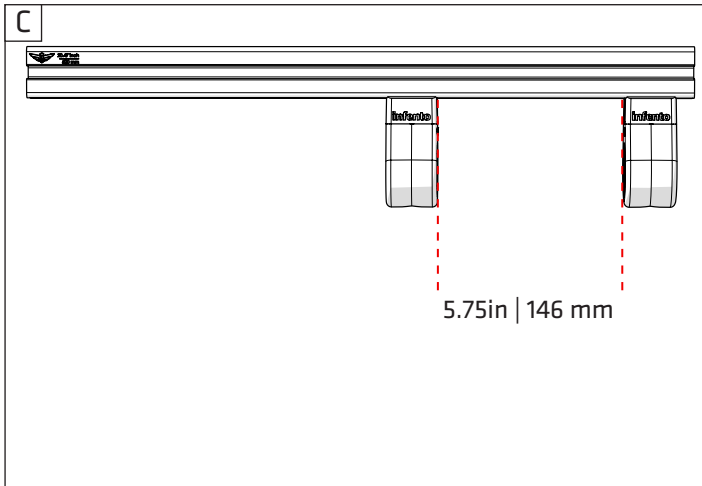



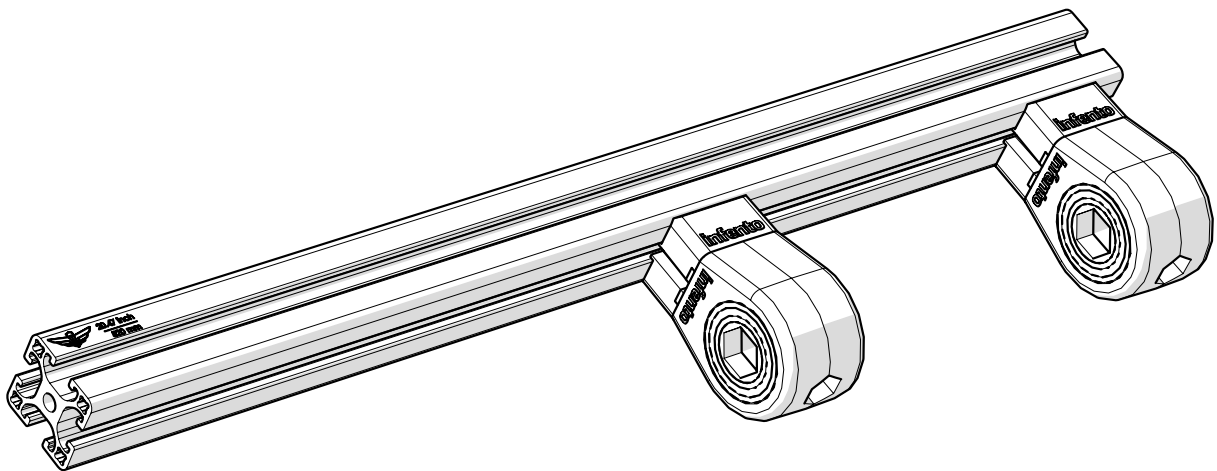

All Infento block bearings have two bearings with a spacer in between. This ensures that you can e.g. put a bolt or a washer tightly against the block bearing without it breaking. A bearing cannot withstand lateral pressure very well; this is because a bearing consists of two washers with small balls locked in between.





3

ride **B-TRIKE**

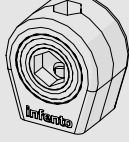
-  Bolt M8x40 1x
-  Positioning block 2x
-  Profile nut short 1x
-  T-plate 1x
-  T-joint 1x
-  Bearing block 40x40_Hexa 19 1x

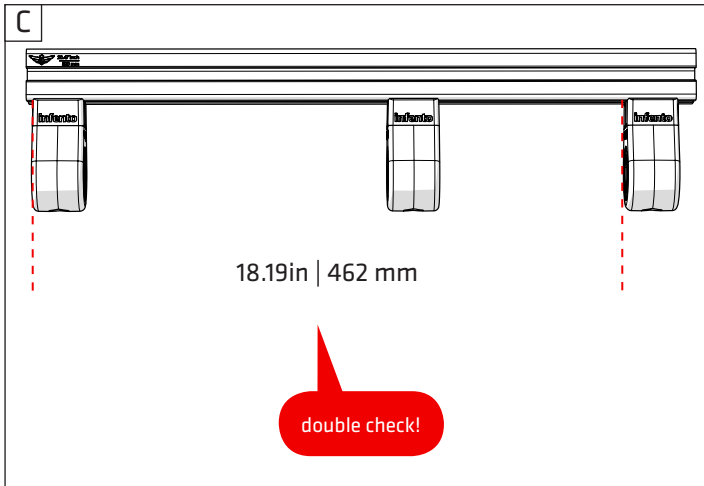
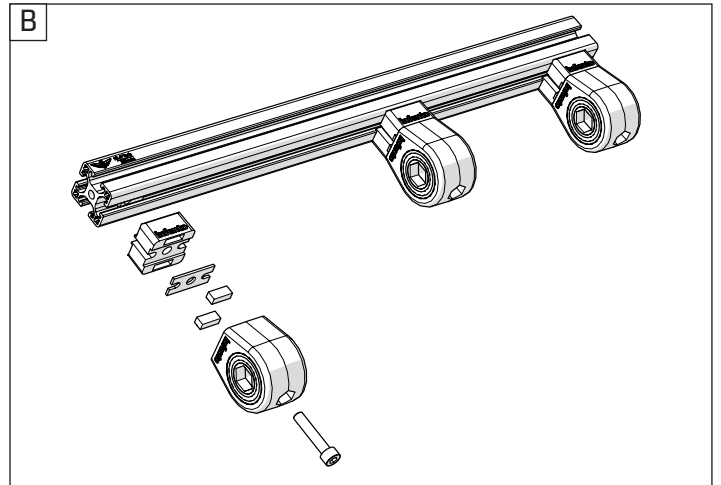
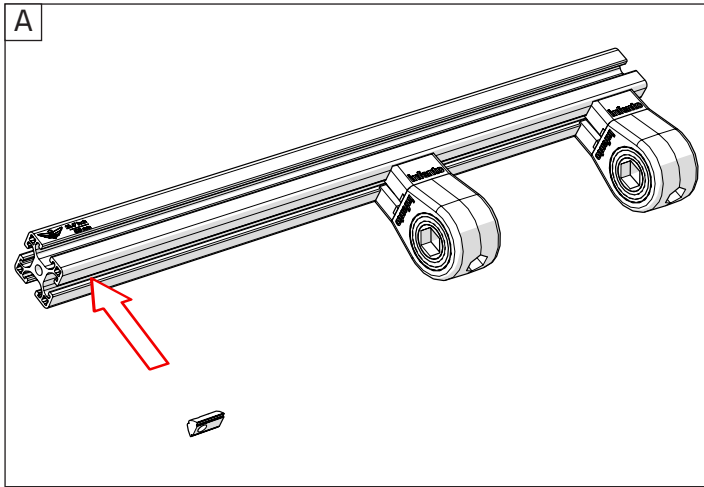

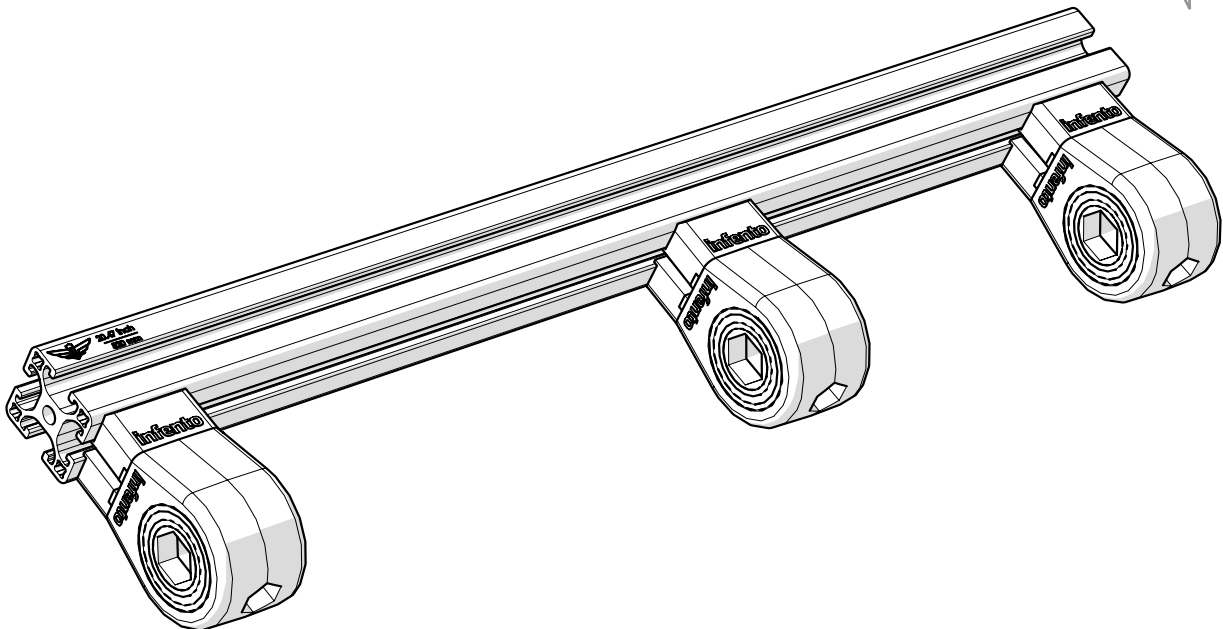

The positioning blocks are some of the smallest Infento parts but they are also some of the most important. They ensure that everything connects to each other properly and prevents parts twisting and coming loose when under pressure. Therefore, always use at least two positioning blocks per block.





4

ride **B-TRIKE**

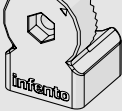
-  1x
-  1x
-  2x
-  1x

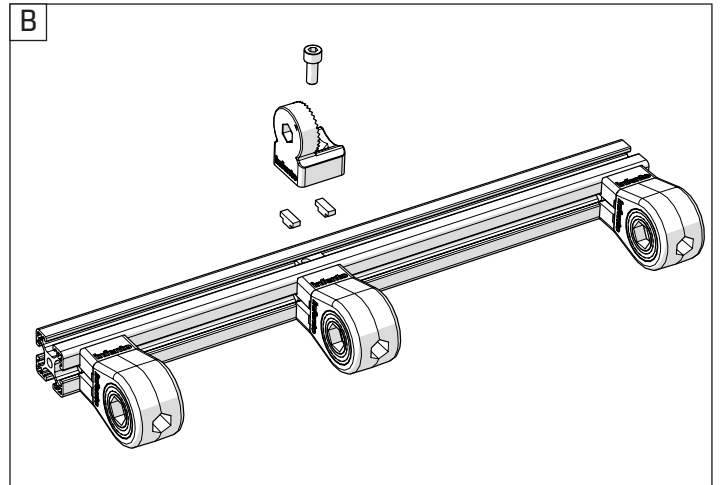
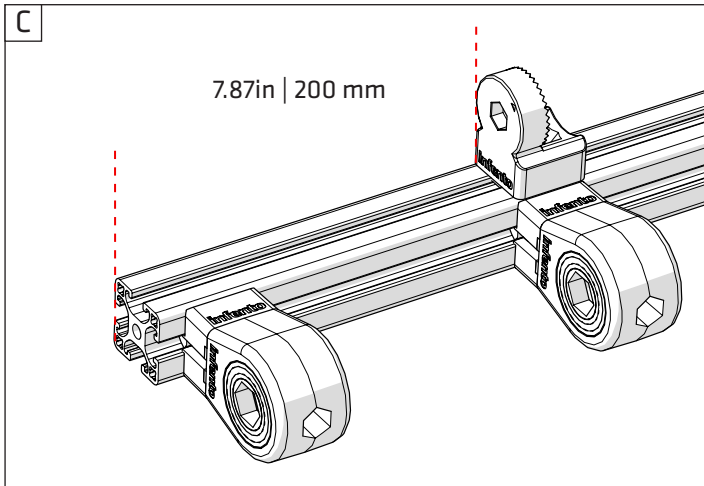
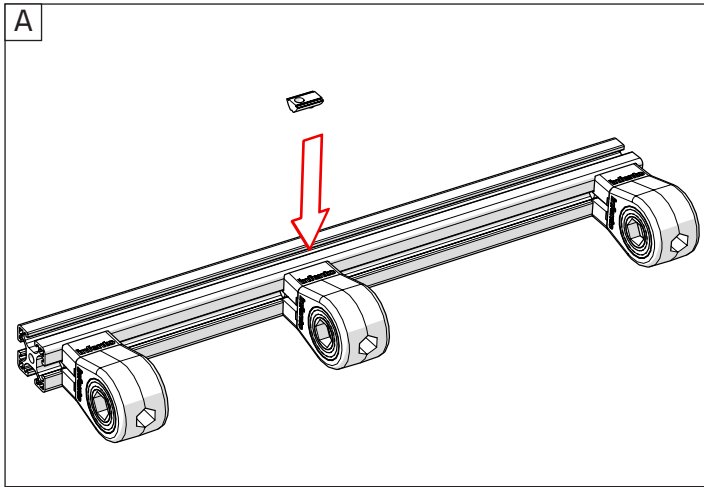

Tighten the bolts with full force. Ensure that you hold the long side of the Allen key in your hand as this enables you to exert greater force.

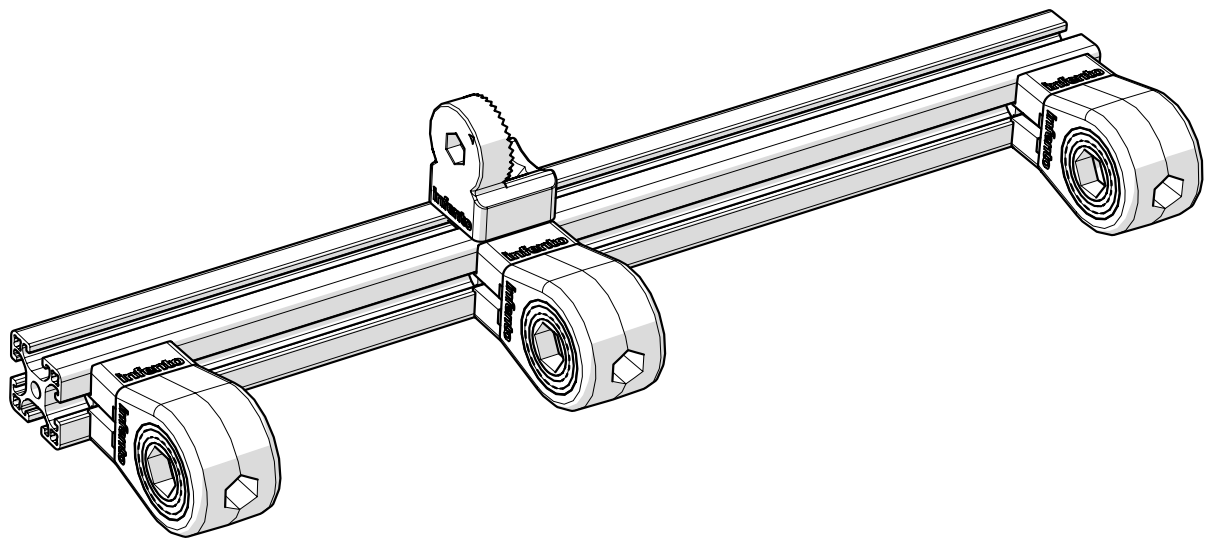



5

ride B-TRIKE

- Profile nut short 1x
- Bolt M8x20 1x
- T-Positioning block 2x
- Multi angle joint 1x

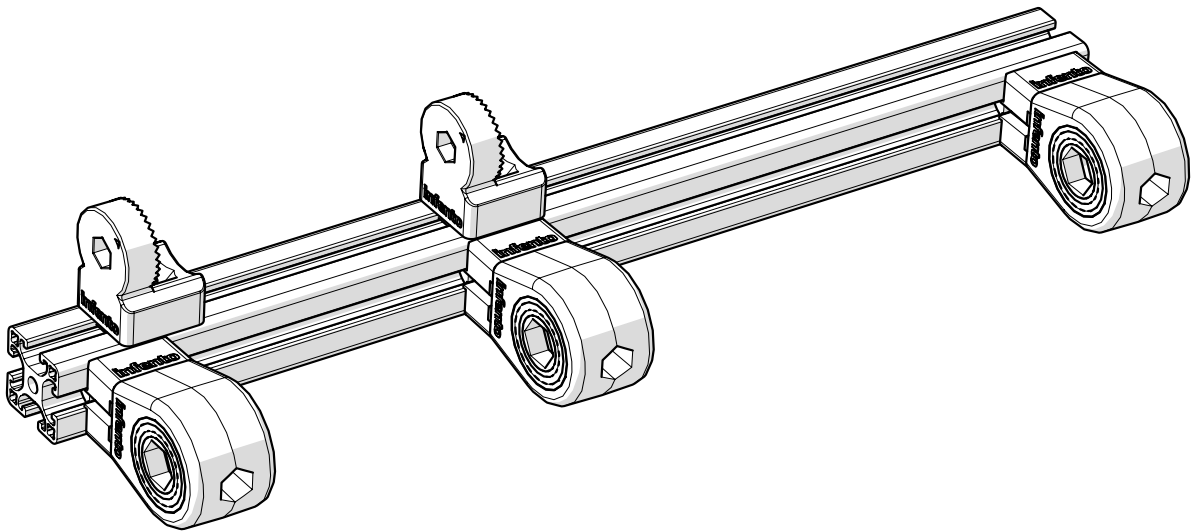
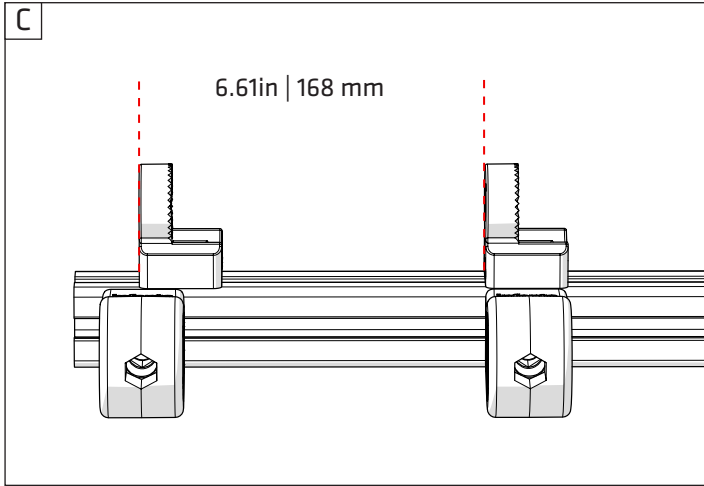
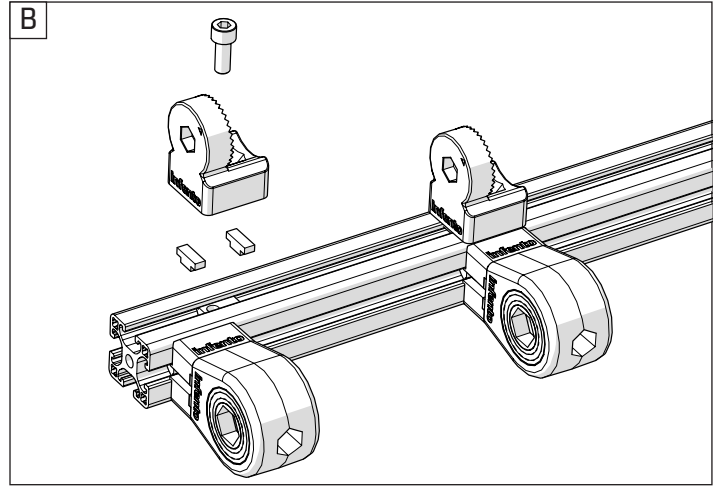
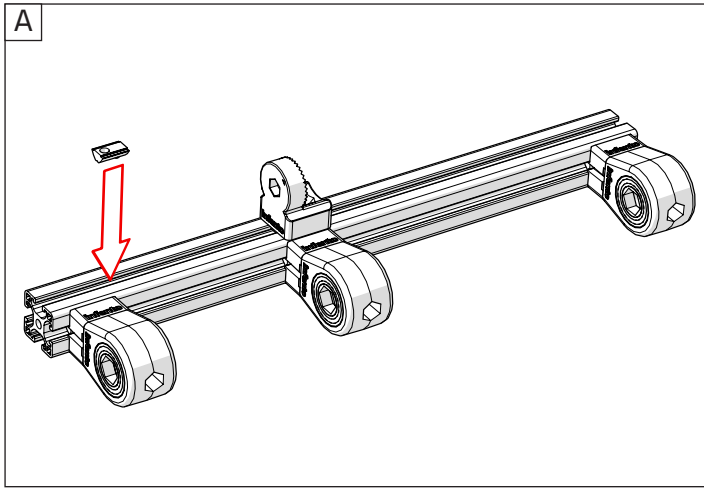



6

ride B-TRIKE

- Profile nut short 1x
- Bolt M8x20 1x
- T-Positioning block 2x
- Multi angle joint 1x

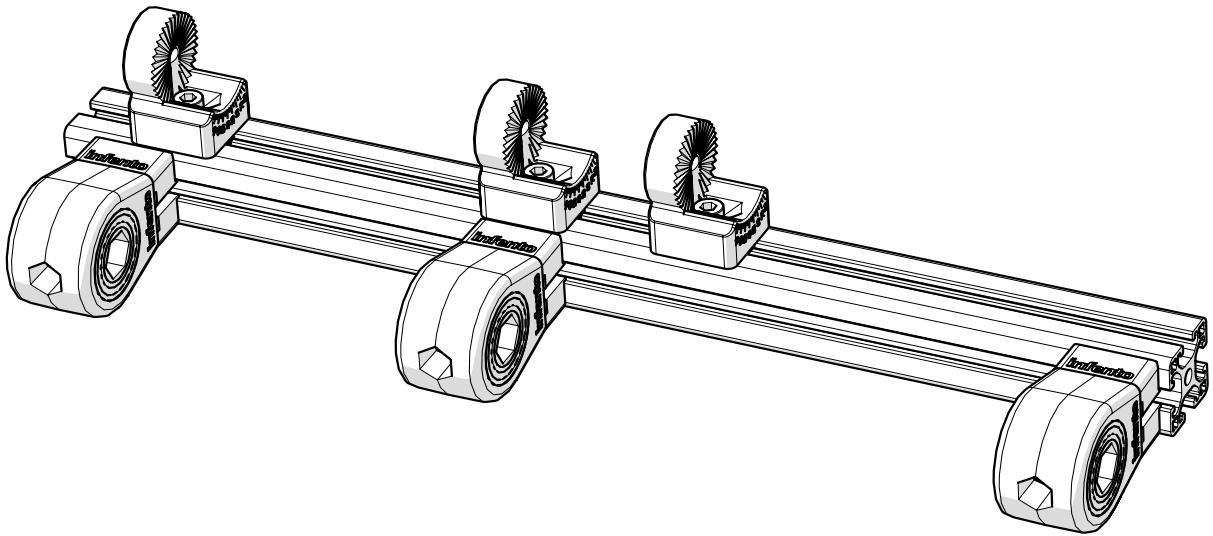
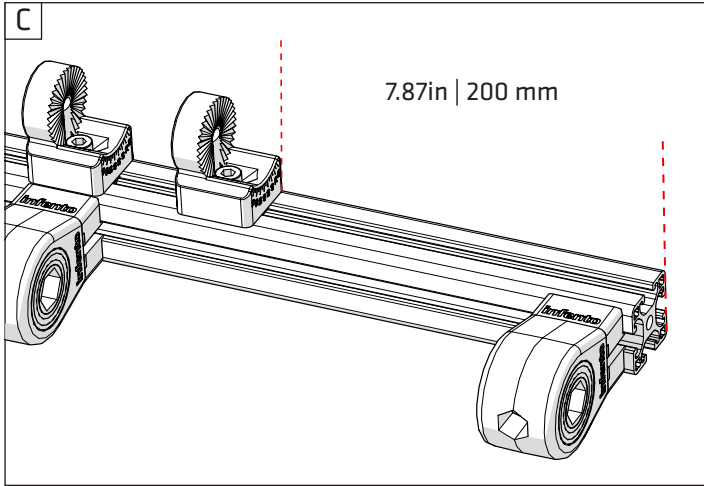
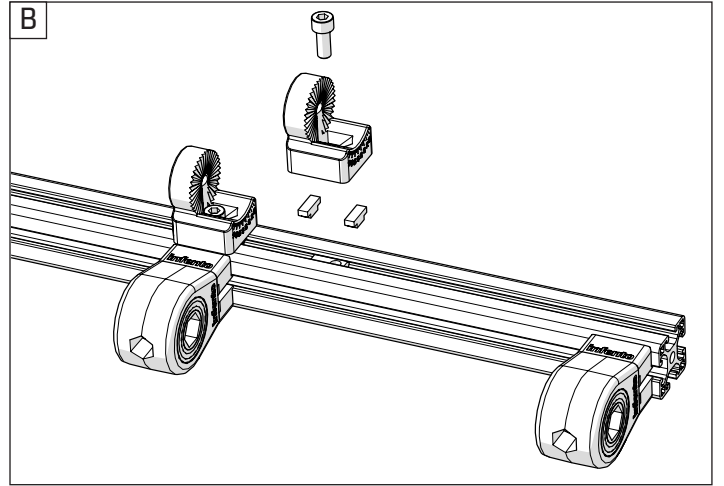
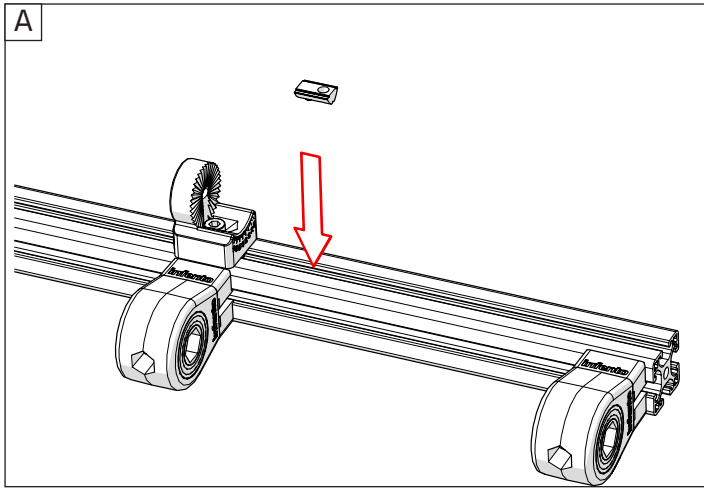



7

ride B-TRIKE

- 1x Profile nut short
- 1x Bolt M8x20
- 2x T-Positioning block
- 1x Multi angle joint

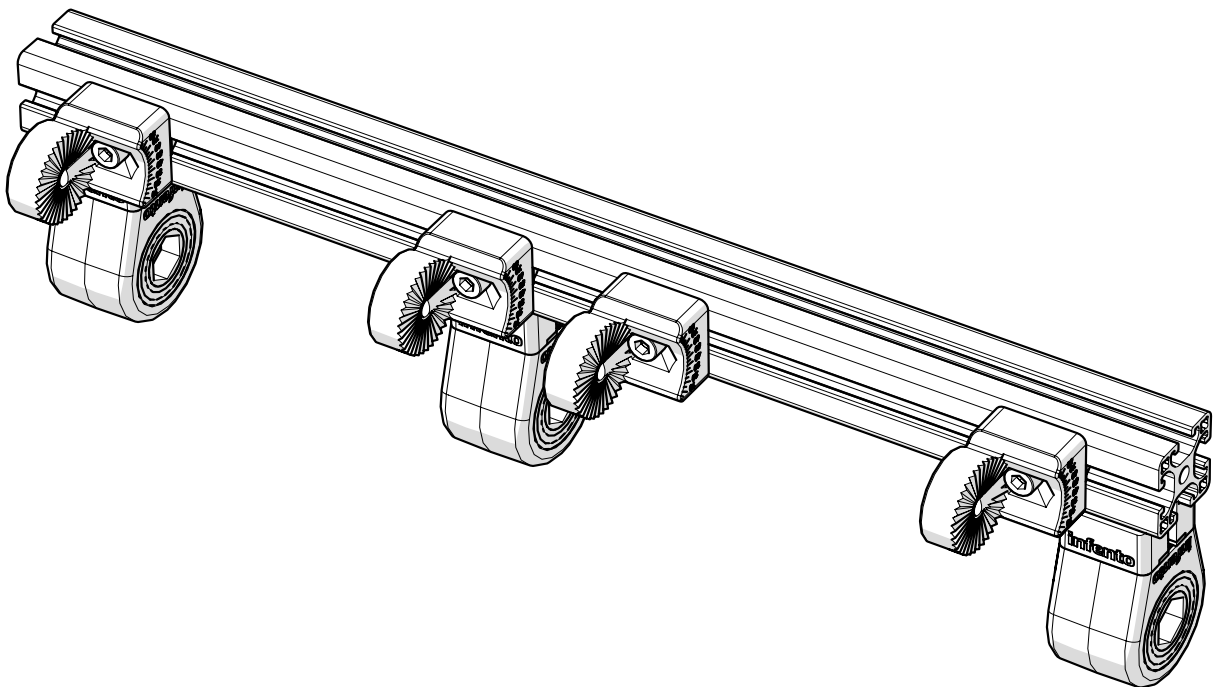
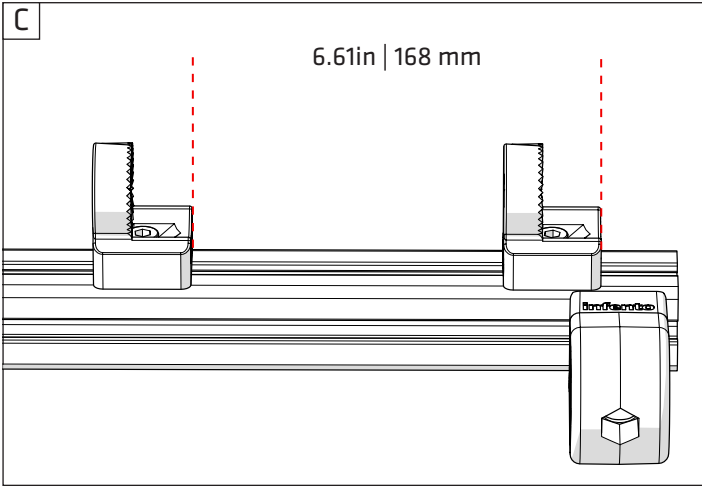
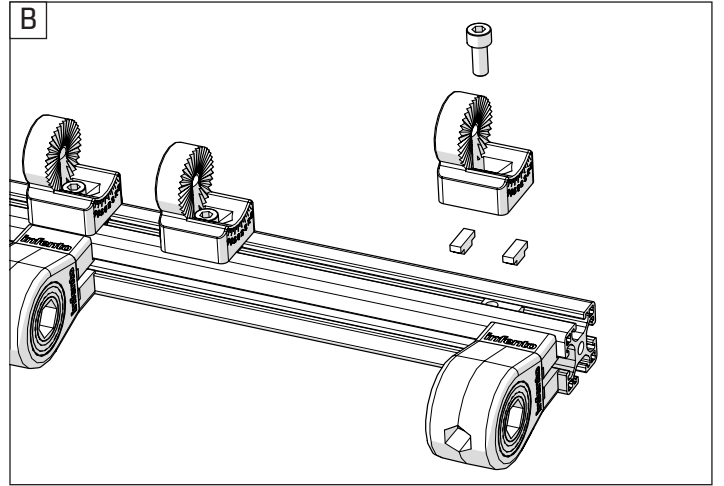
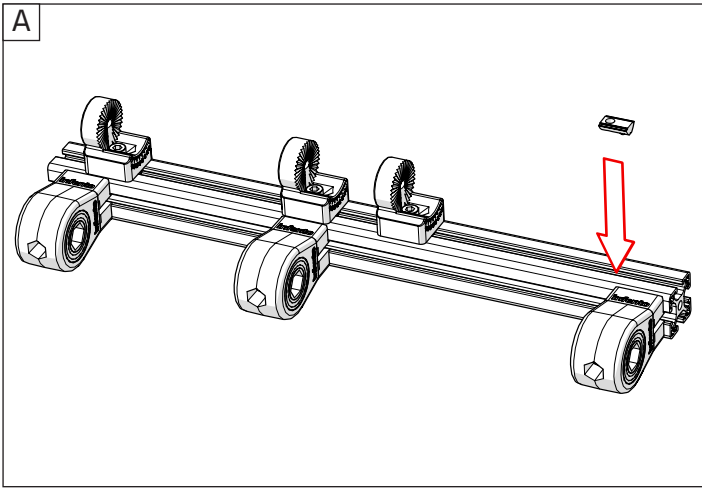



8

ride B-TRIKE



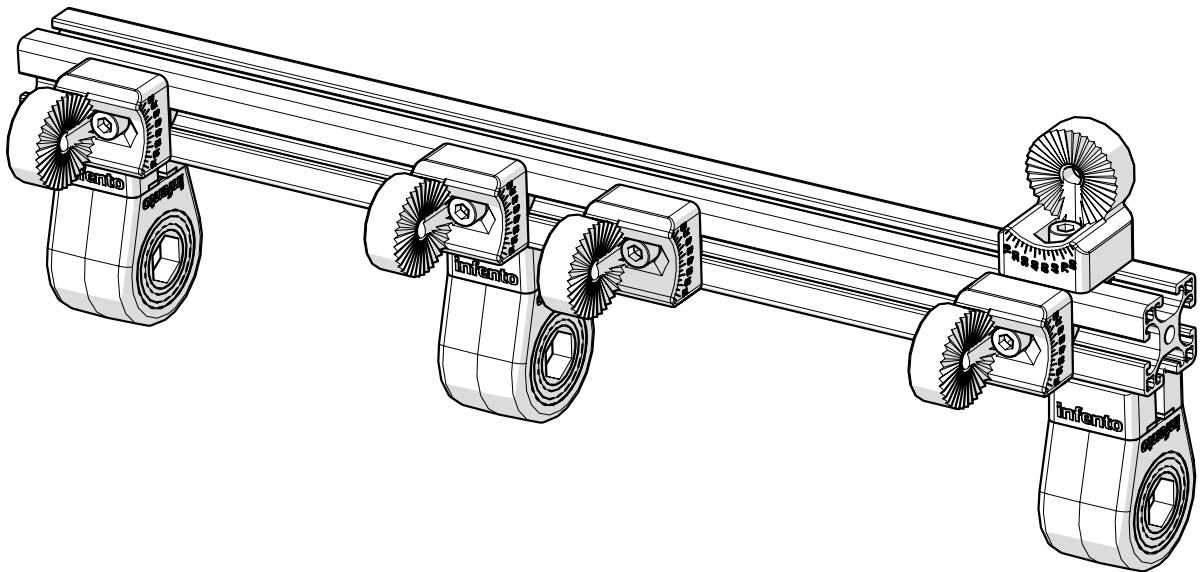
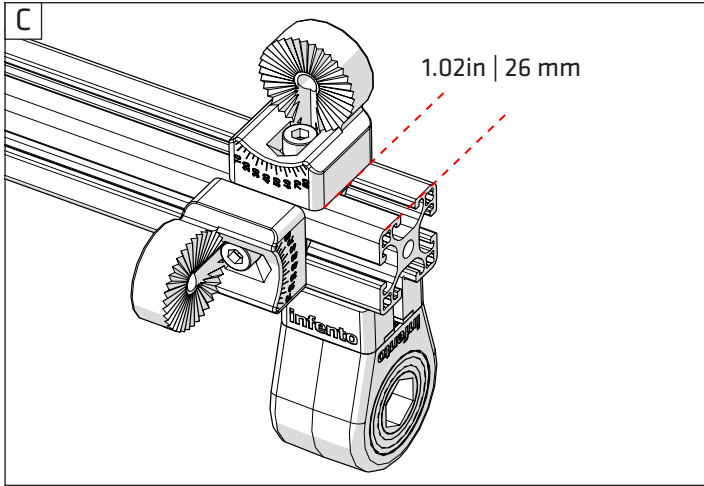
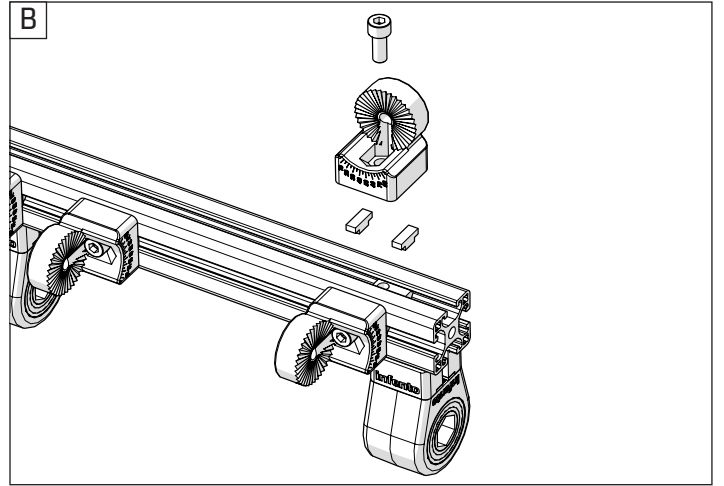
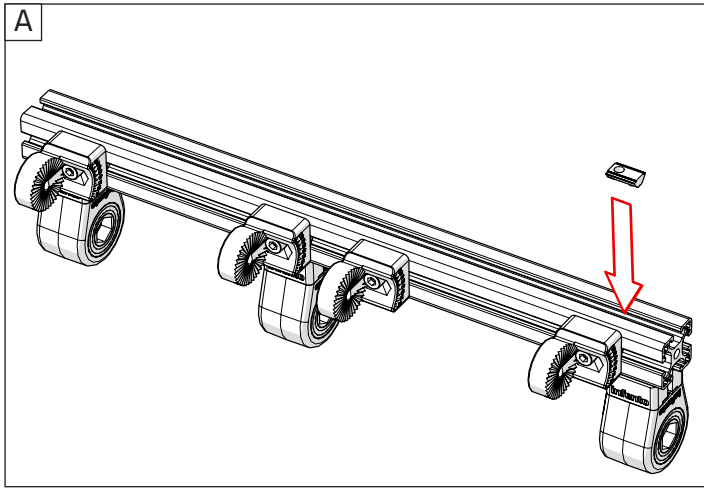

- Profile nut short 1x
- Bolt M8x20 1x
- T-Positioning block 2x
- Multi angle joint 1x





9

ride B-TRIKE

-  1x
-  1x
-  2x
-  1x

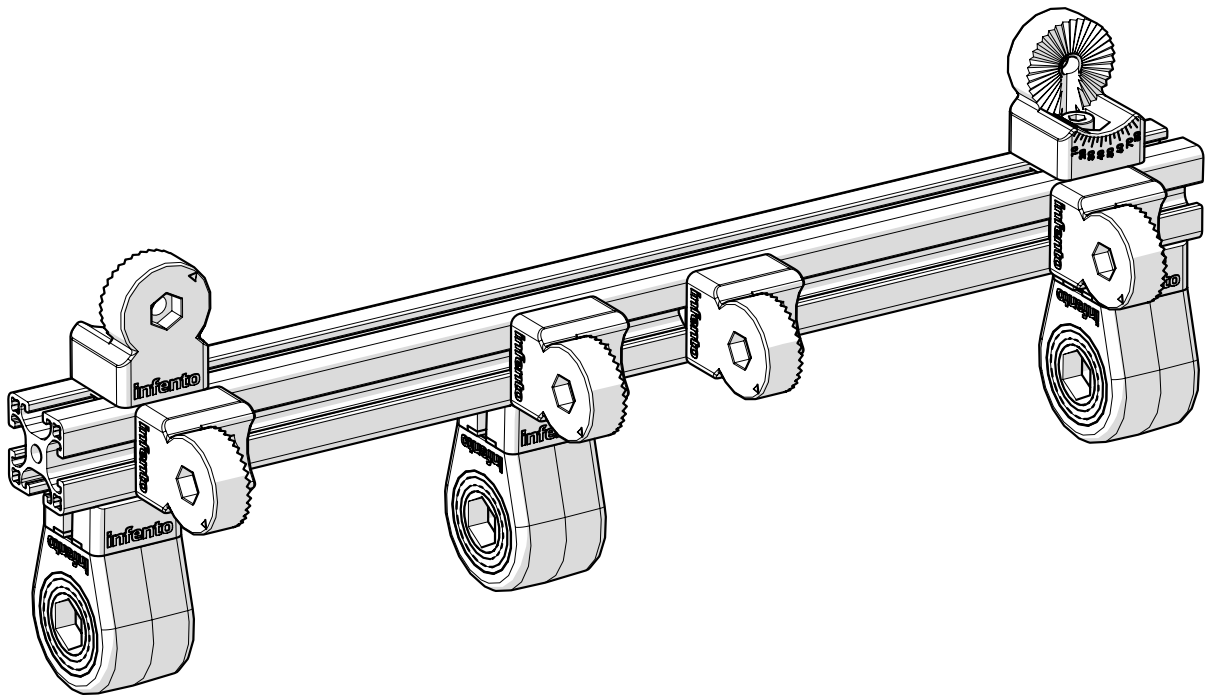
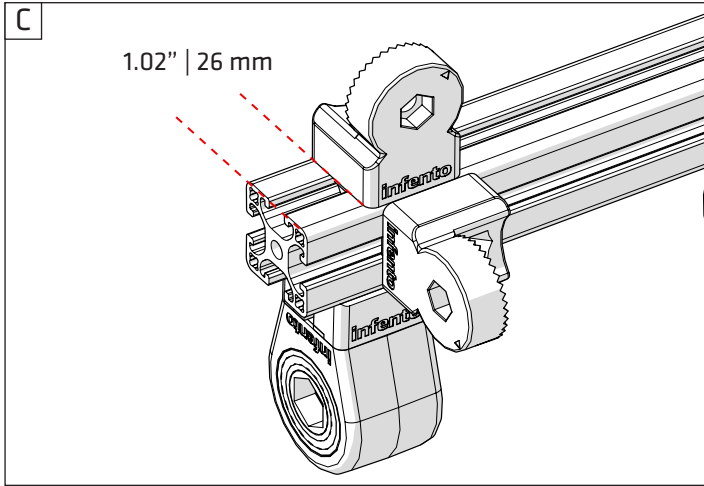
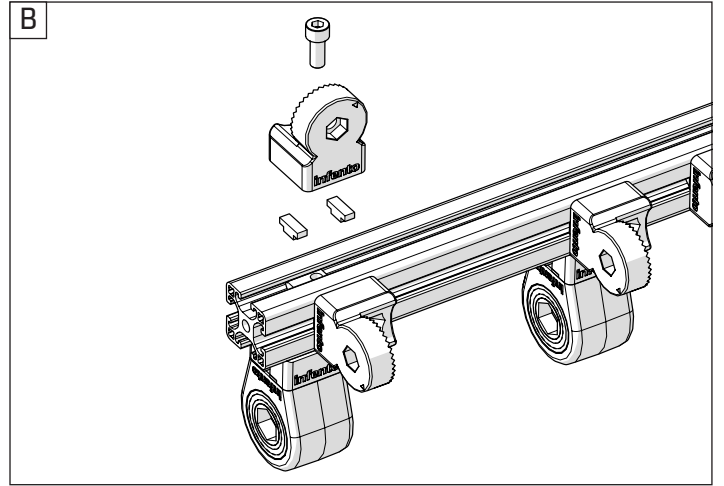
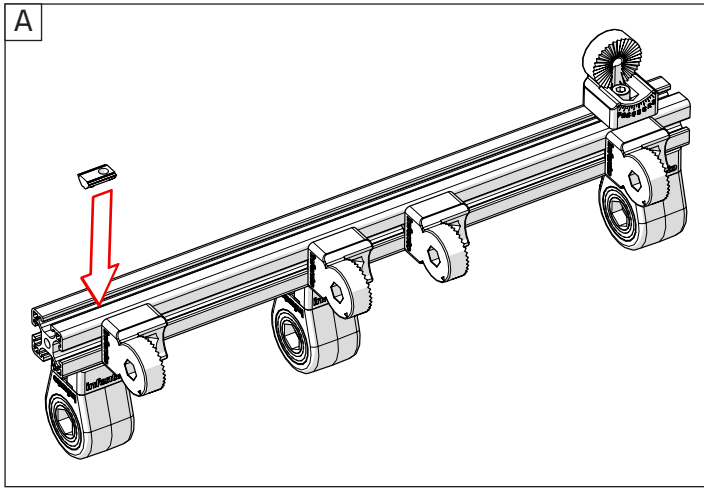



10

ride B-TRIKE

- T-Positioning block 6x
- Bolt M8x20 (low head) 2x
- L-joint 2x
- Profile 1.57inch | 40mm 1x

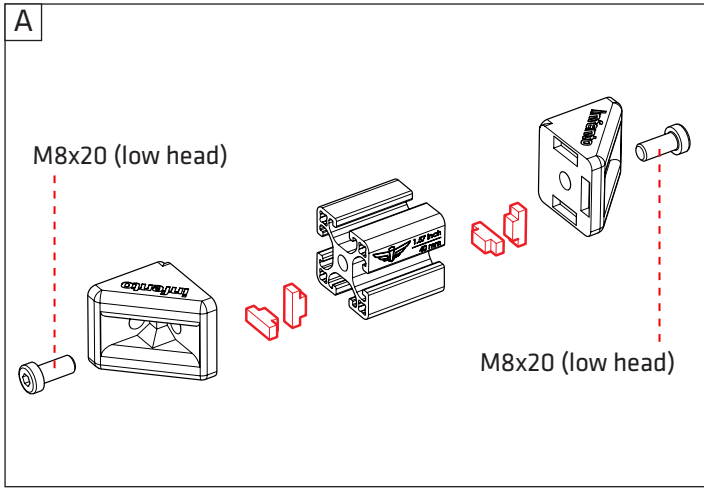

- Bolt M8x20 1x
- Profile nut short 1x
- Multi angle joint 1x

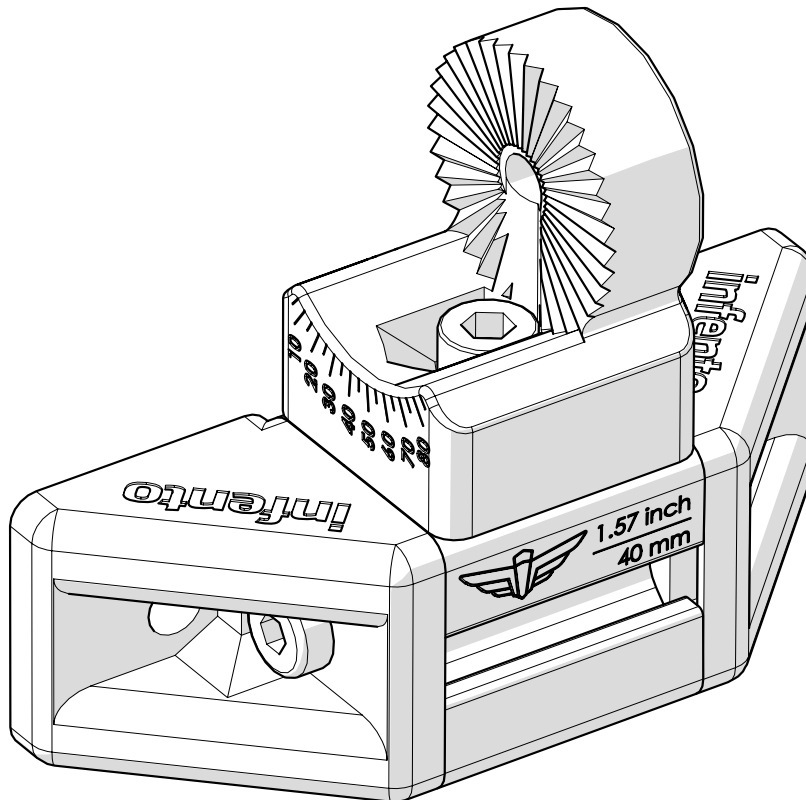
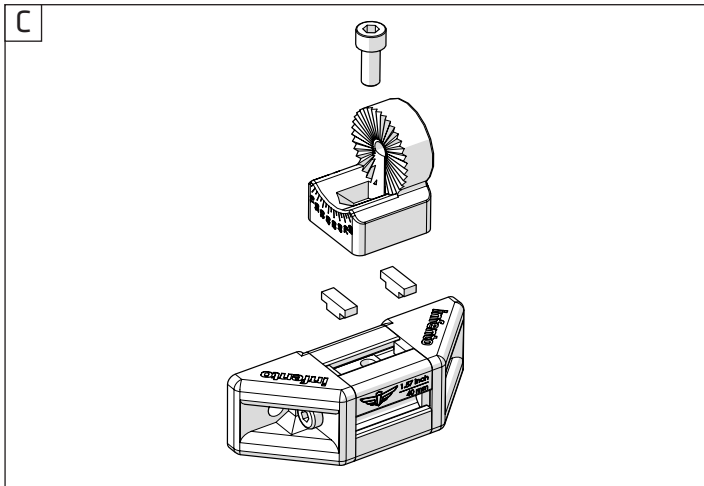
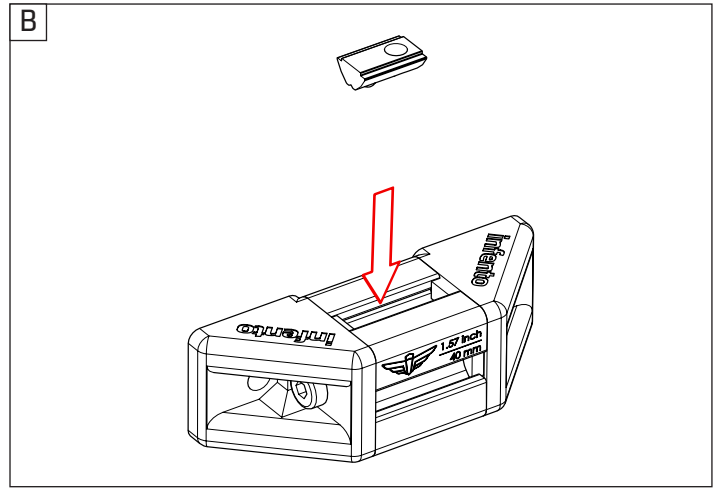



11

ride B-TRIKE

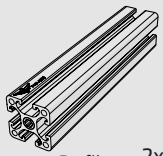

Profile 2x
22.05inch | 560mm

+



Bolt M8x20
(low head) 2x

+



Bolt M8x20
2x

+



T-Positioning block
8x

+



Profile nut short
2x

+





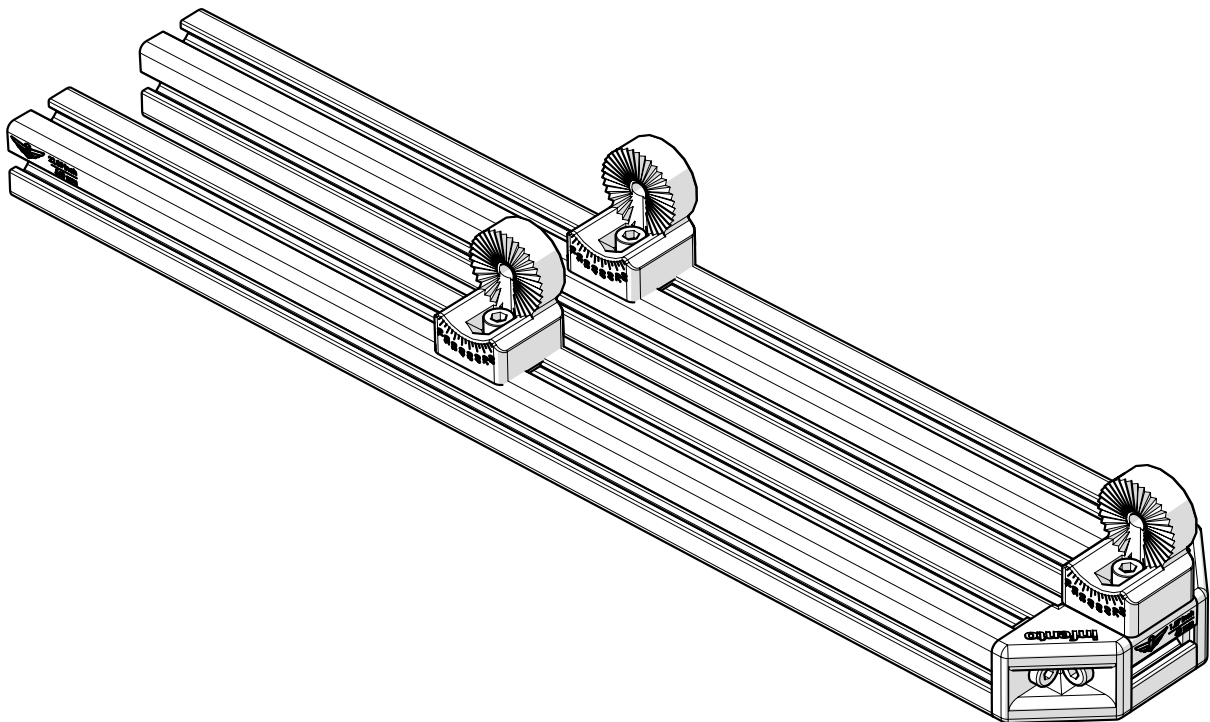
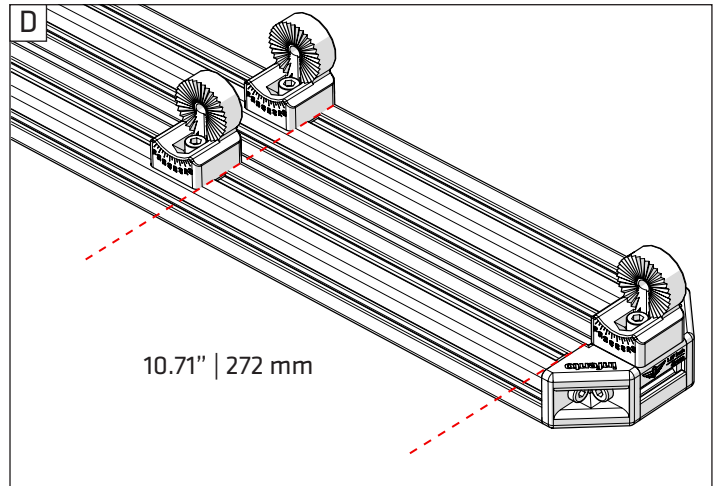
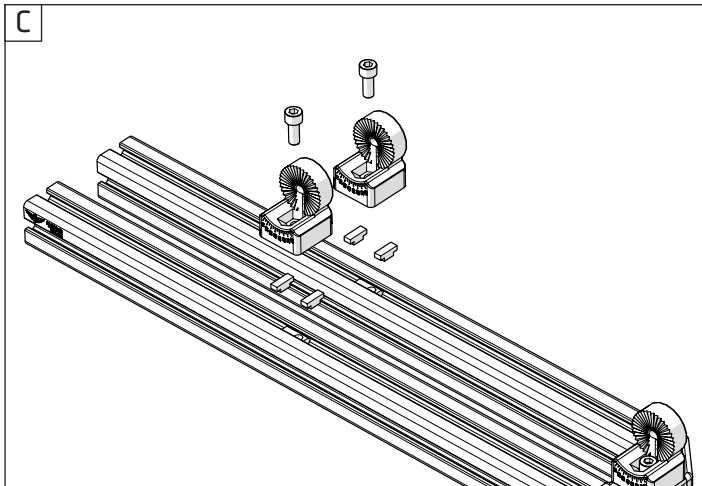
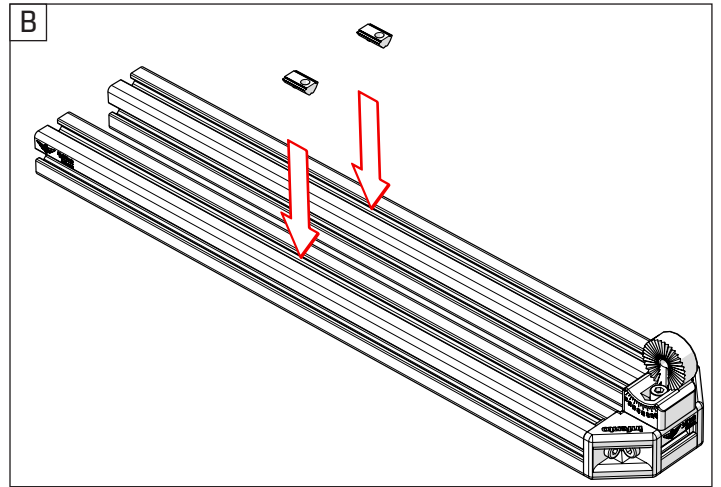
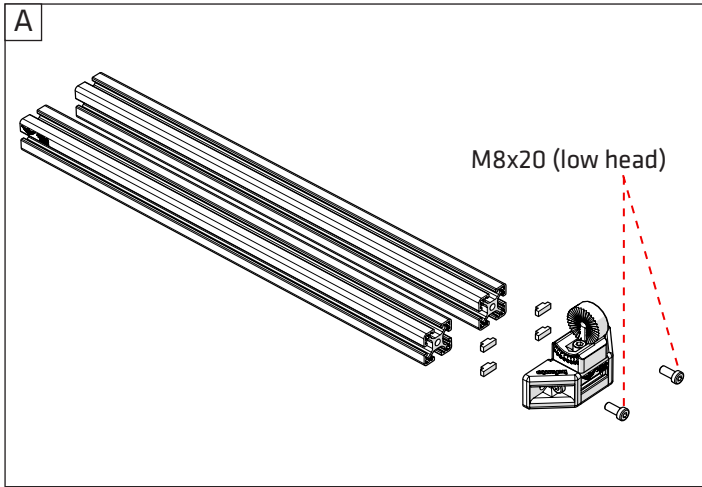

Multi angle joint
2x





12

ride **B-TRIKE**



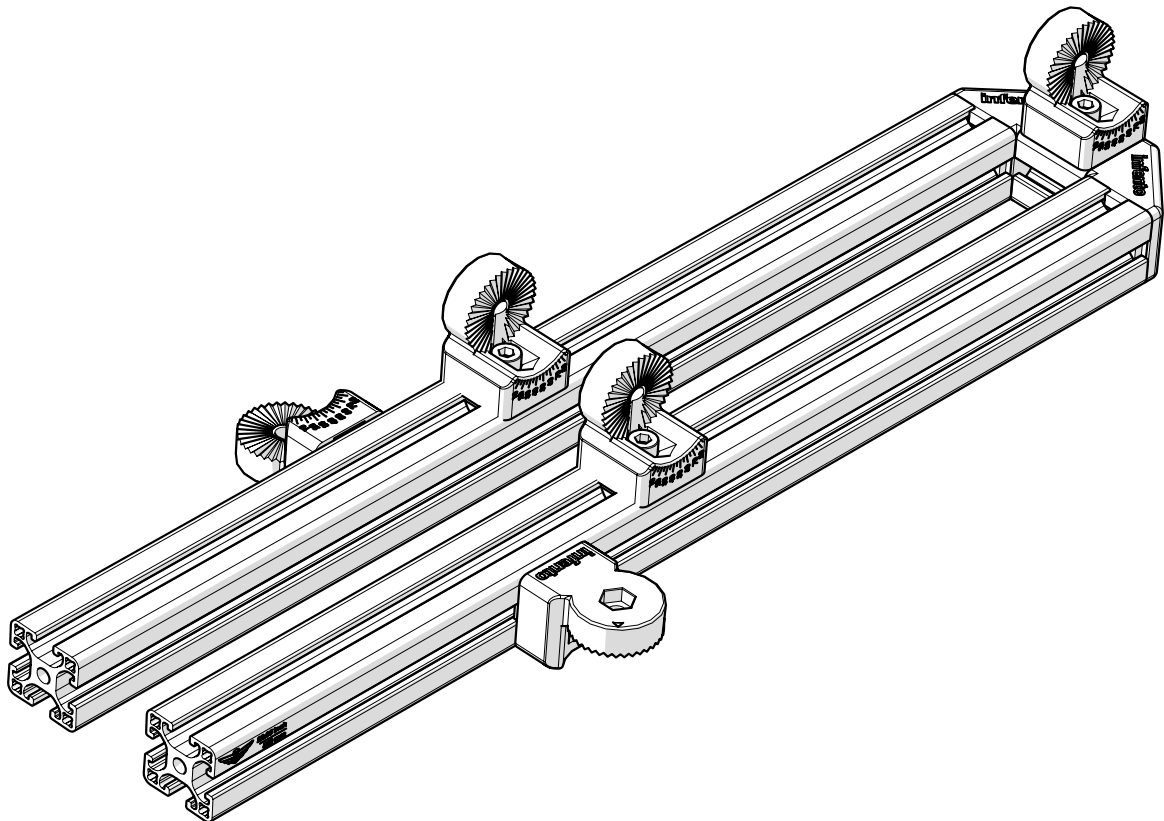
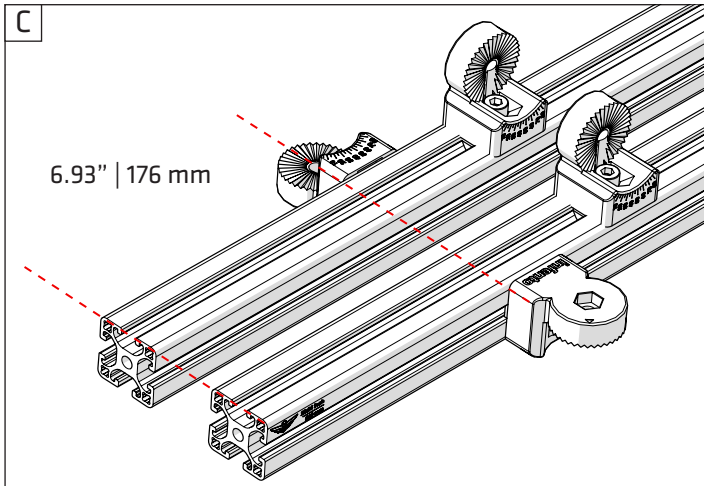
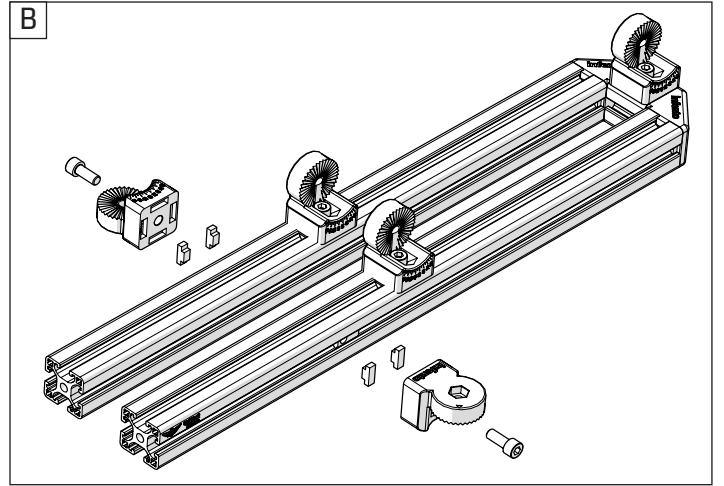
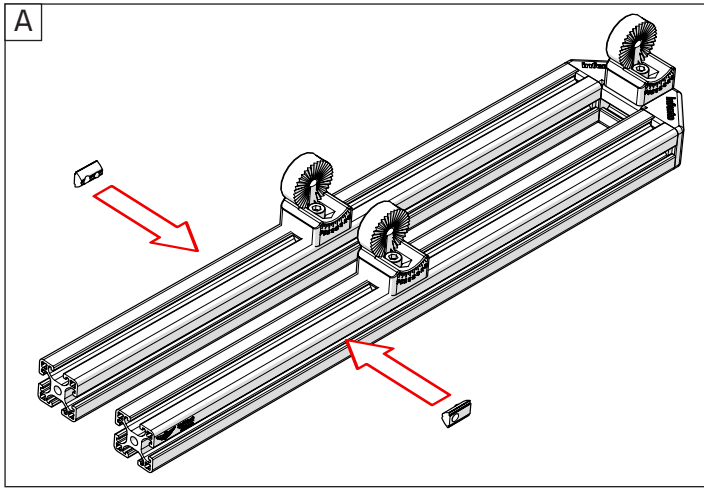



-  2x
-  4x
-  2x
-  2x



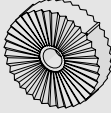

13

ride **B-TRIKE**

- 
 Bolt M8x35 2x
- 
 Locknut M8 2x
- 
 Knurled disc 1 stripe 2x
- 
 Bolt M8x20 2x
- 
 T-Positioning block 4x
- 
 Multi angle joint 2x

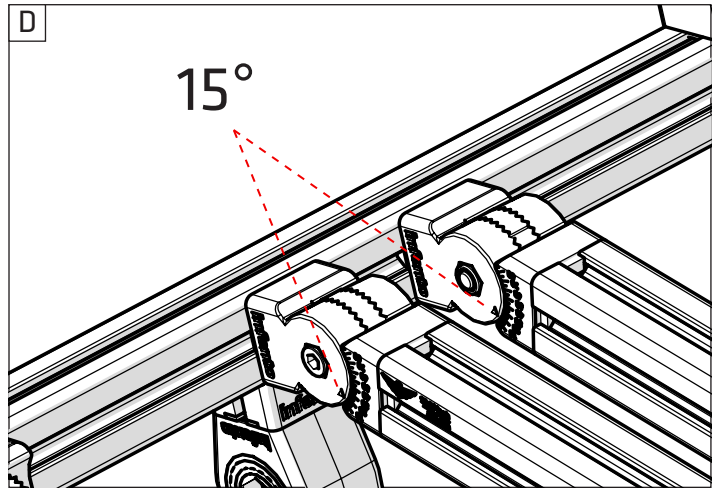
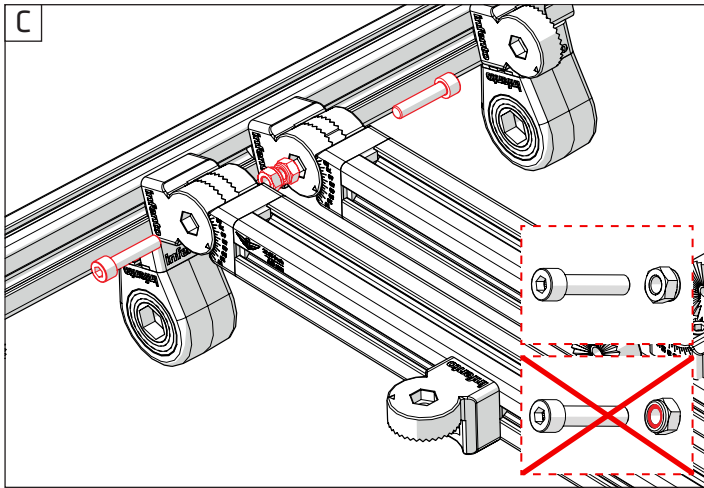
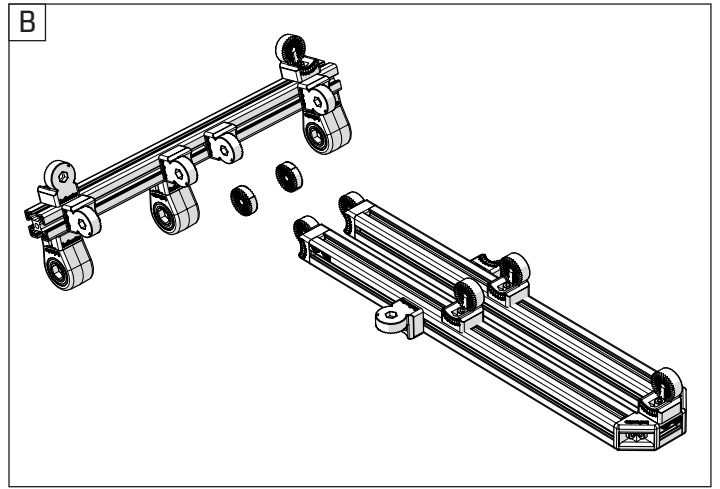
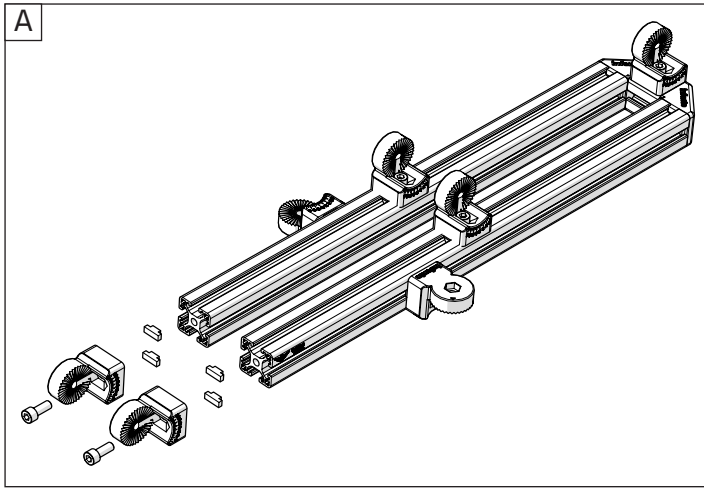

There are two types of knurled discs. Please see education section.

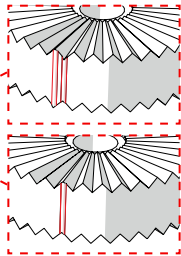



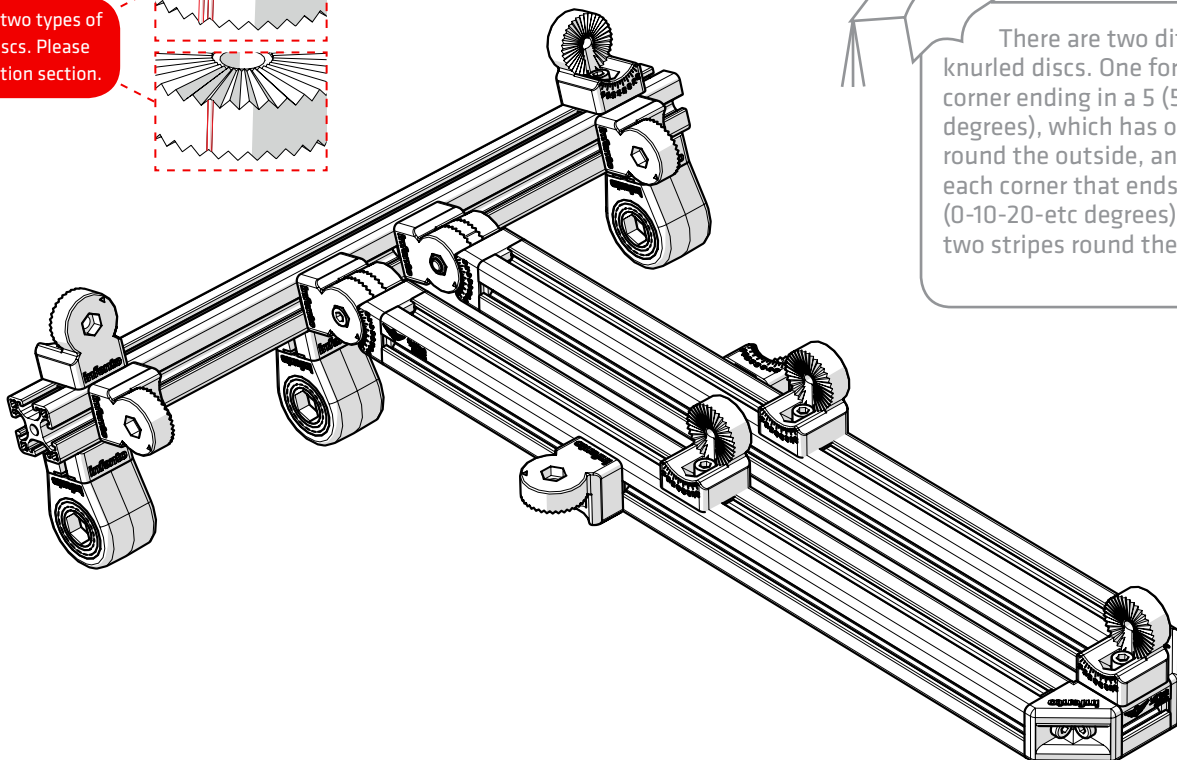

There are two different knurled discs. One for each corner ending in a 5 (5-15-25-etc. degrees), which has one stripe round the outside, and one for each corner that ends in a 0 (0-10-20-etc degrees), which has two stripes round the outside.





14

ride B-TRIKE

-  1x
-  1x
-  2x
-  2x

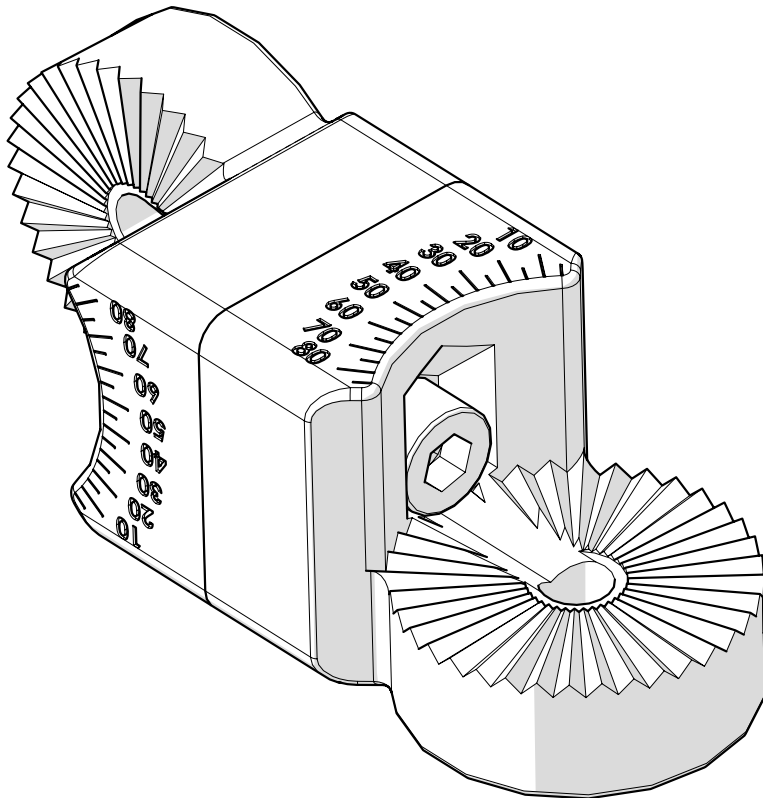
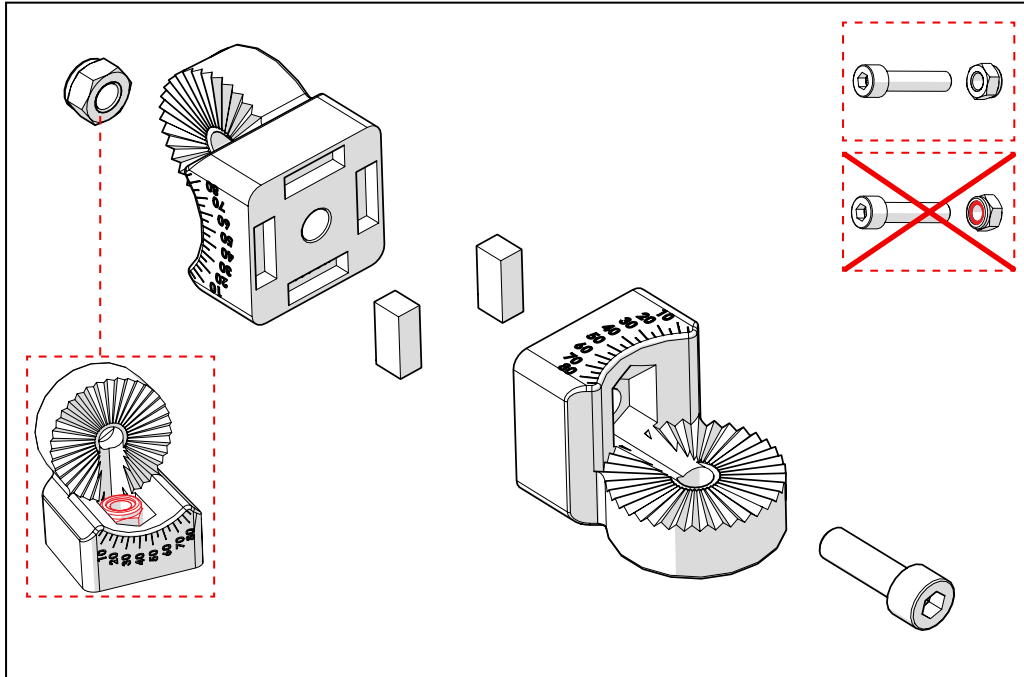



15

ride B-TRIKE

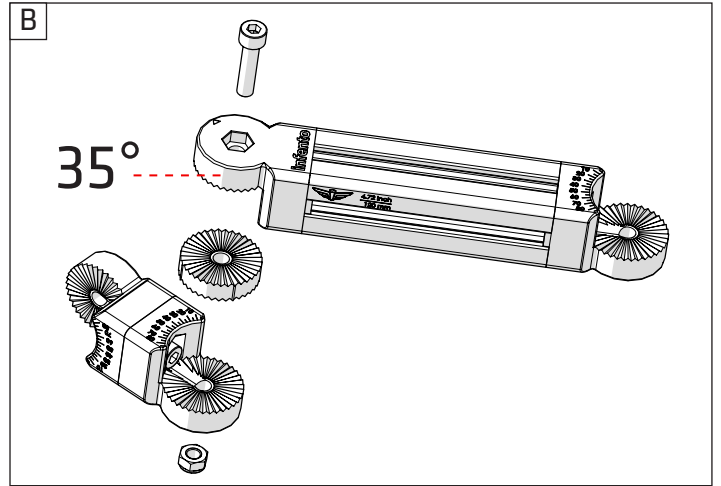
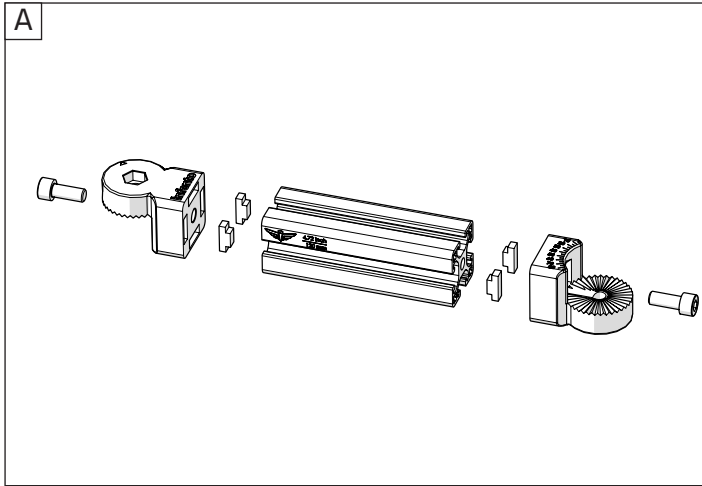
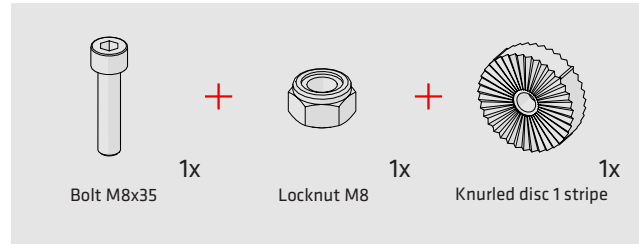
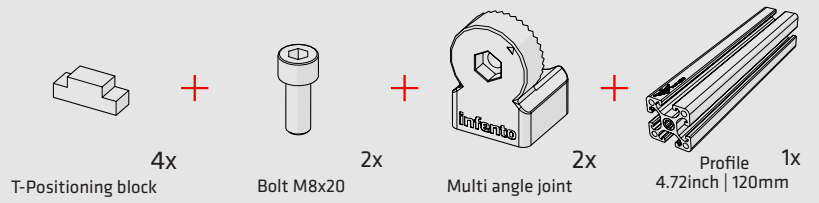

The Infento profiles are made of aluminium. This is a light and strong metal that is also used to build aeroplanes. A major advantage is that aluminium does not rust like iron.

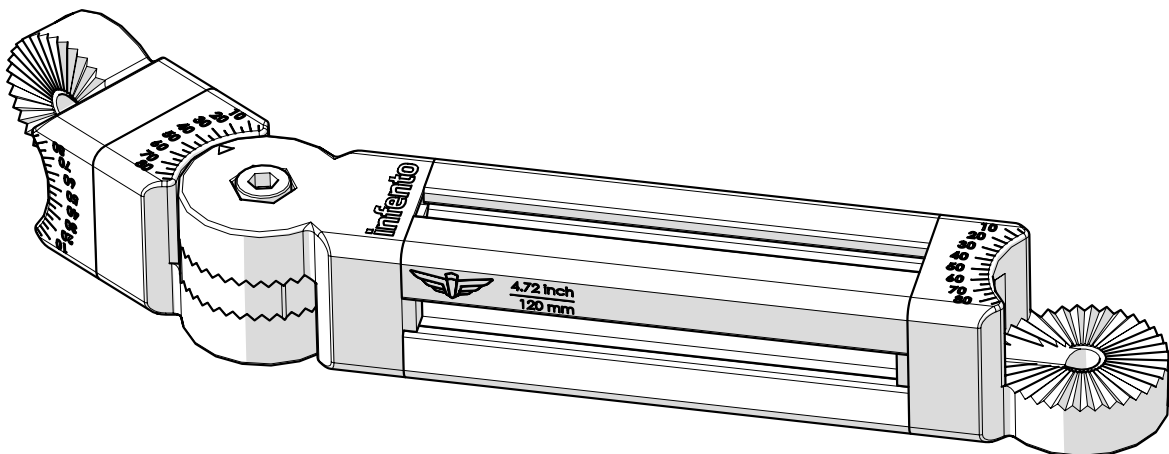



16

ride B-TRIKE

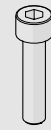

2x

Bolt M8x35

+



2x

Locknut M8

+

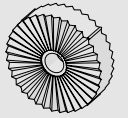

2x

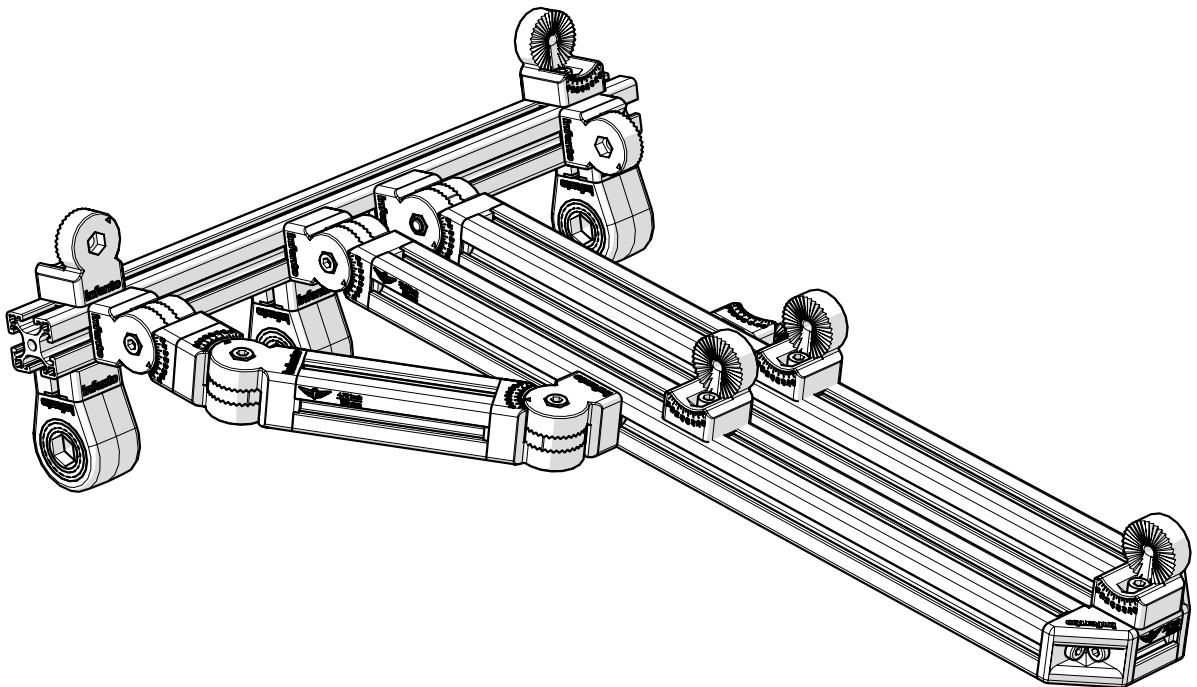
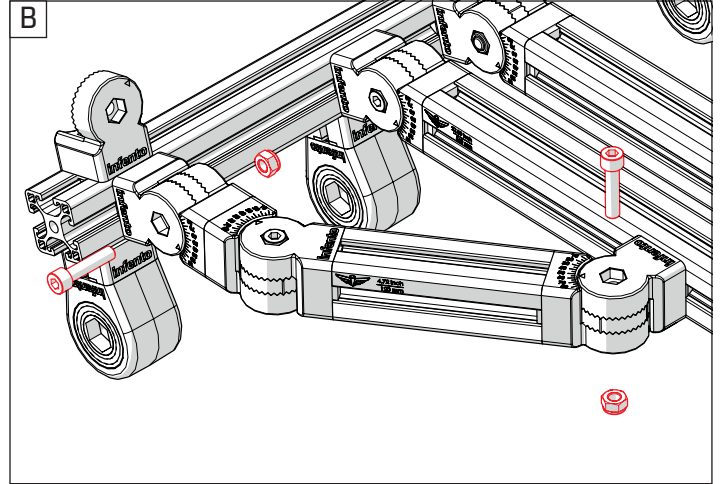
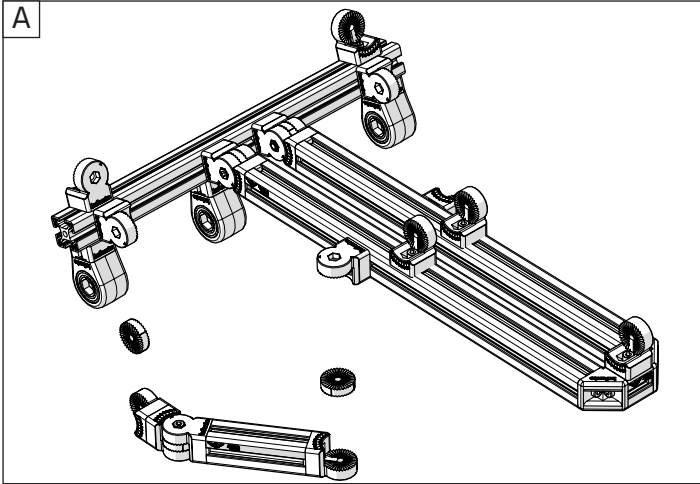

Knurled disc 1 stripe





17

ride B-TRIKE

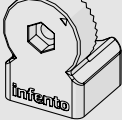
- 
Locknut M8
- +
- 
Bolt M8x25
- +
- 
Positioning block
- +
- 
Multi angle joint

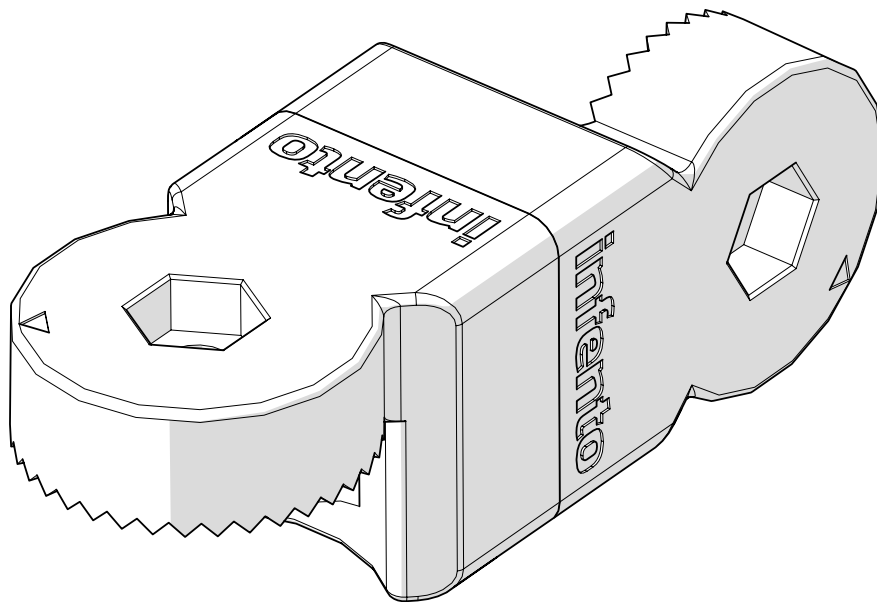
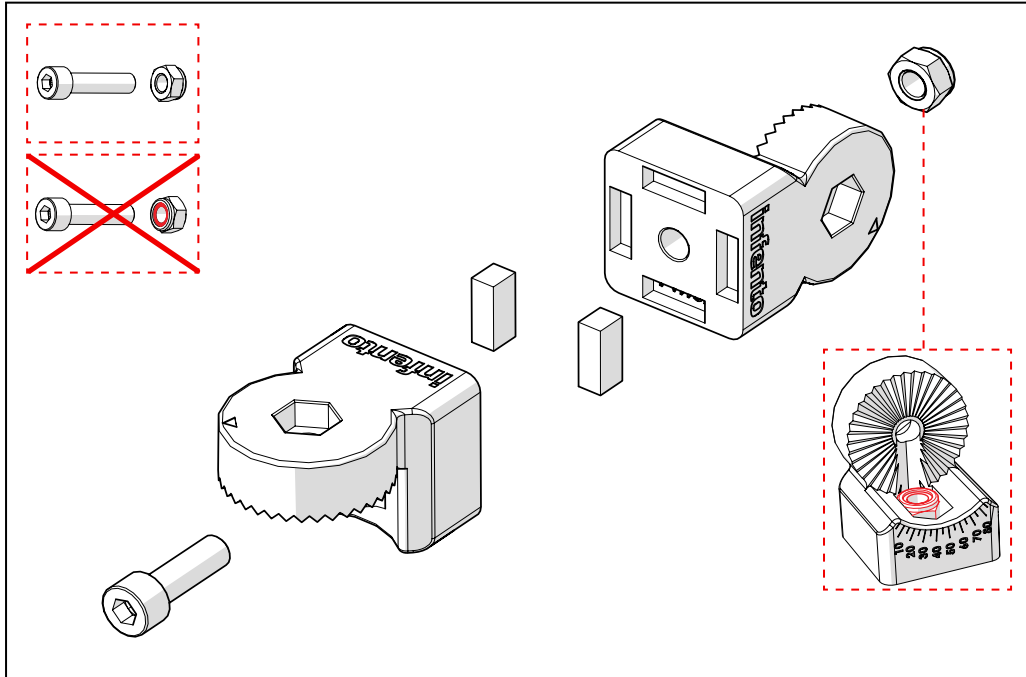



18

ride B-TRIKE

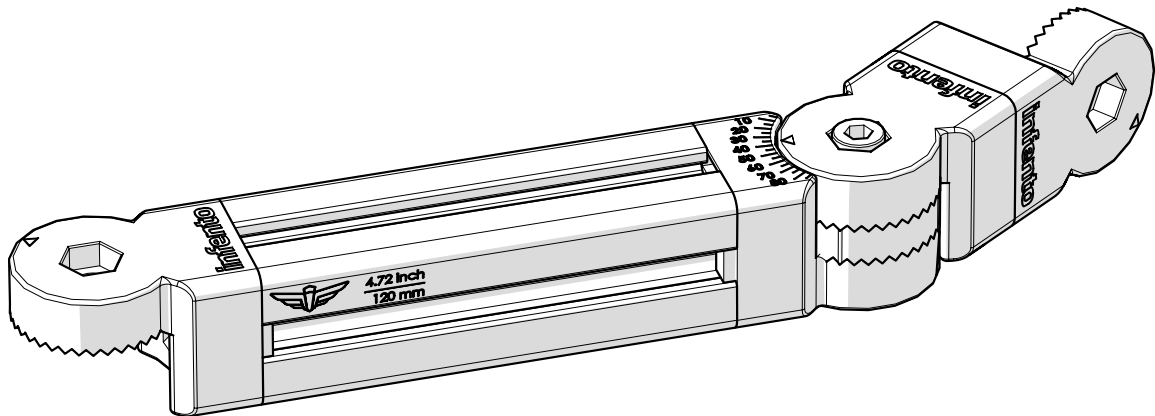
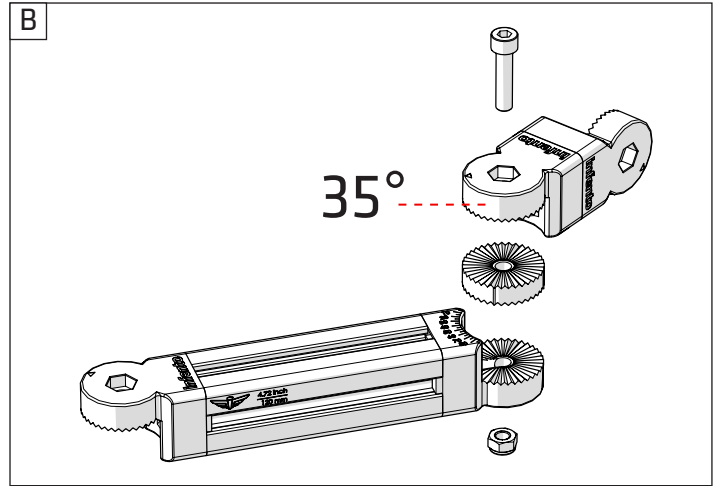
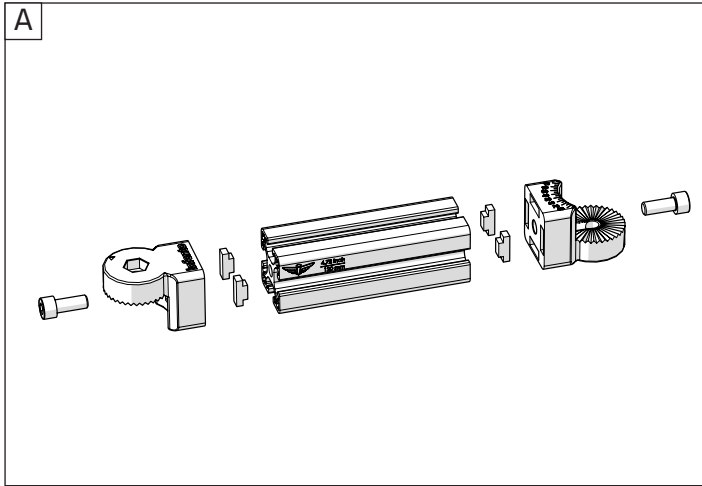
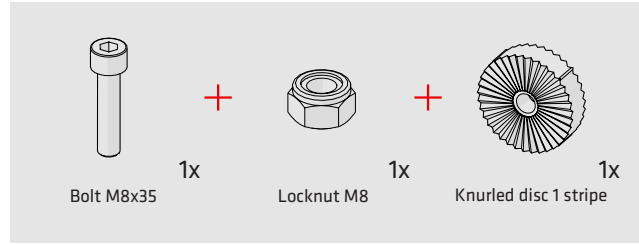
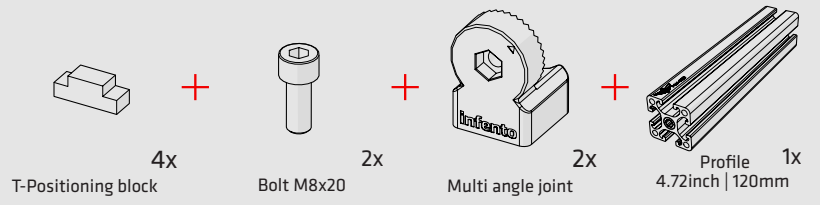



19

ride *B-TRIKE*



2x



2x

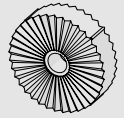

2x

Bolt M8x35

Locknut M8

Knurled disc 1 stripe

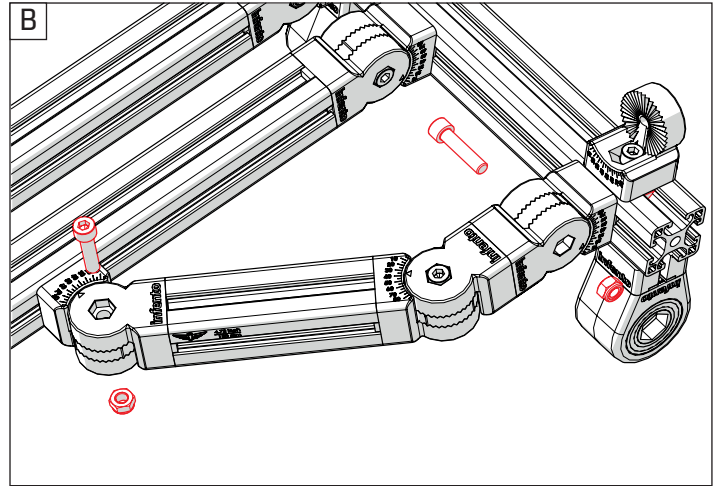
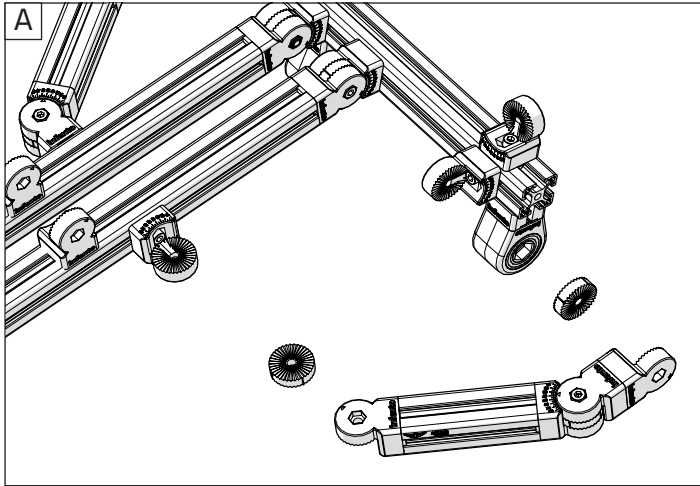

Most nuts that you use for Infento are self-locking. This means that they cannot vibrate loose. On the inside of the bolt you will see a plastic washer that ensures it cannot turn freely, even if there is no tension on the bolt.

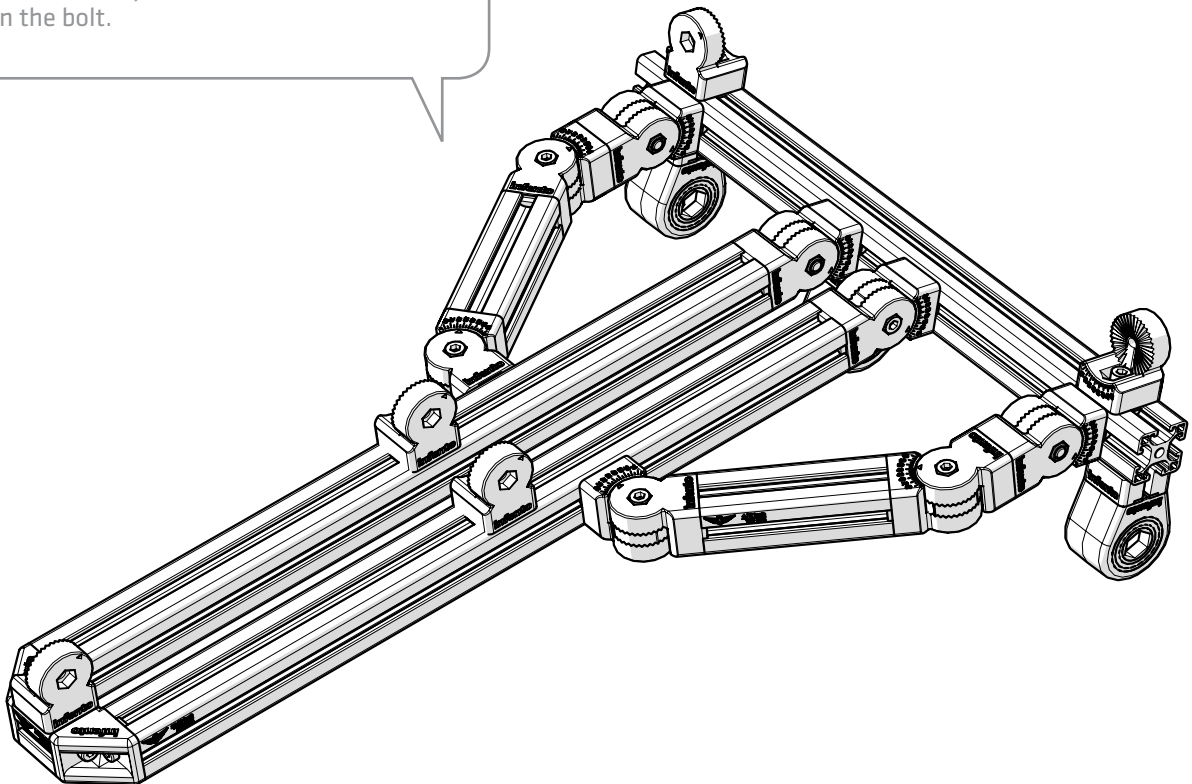



20

ride **B-TRIKE**



Bolt M8x20

2x

+



Profile nut short

2x

+

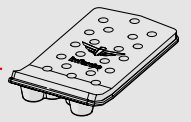

Ducktail board + foam

1x

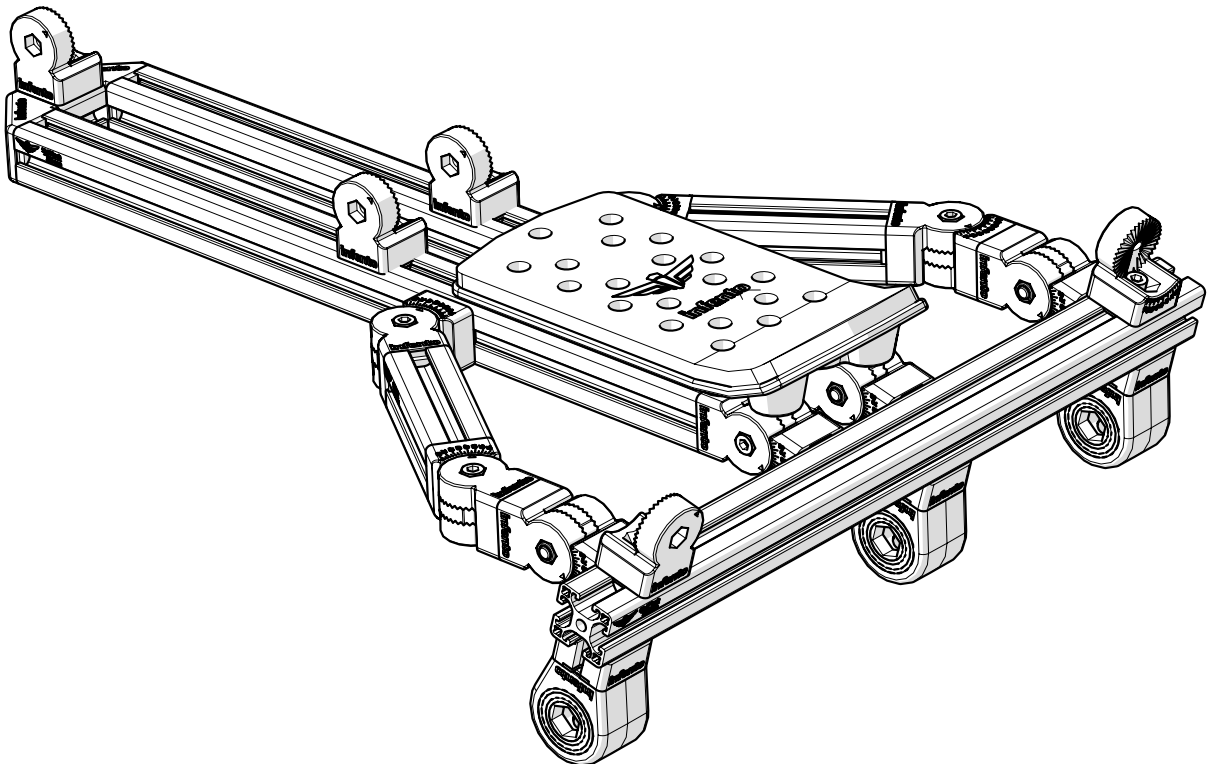
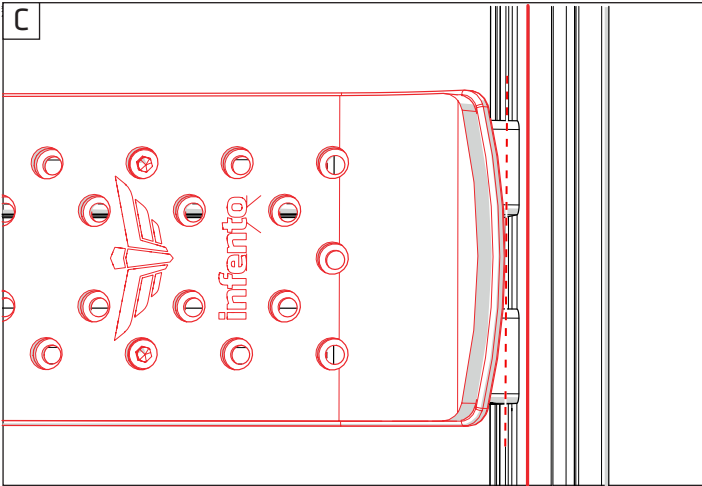
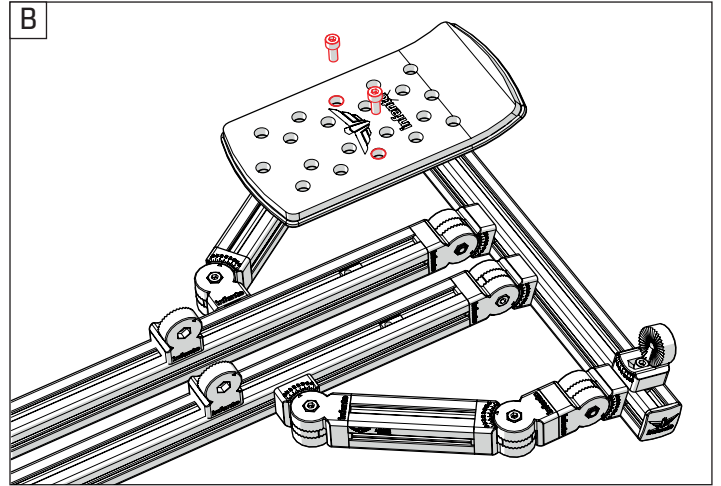
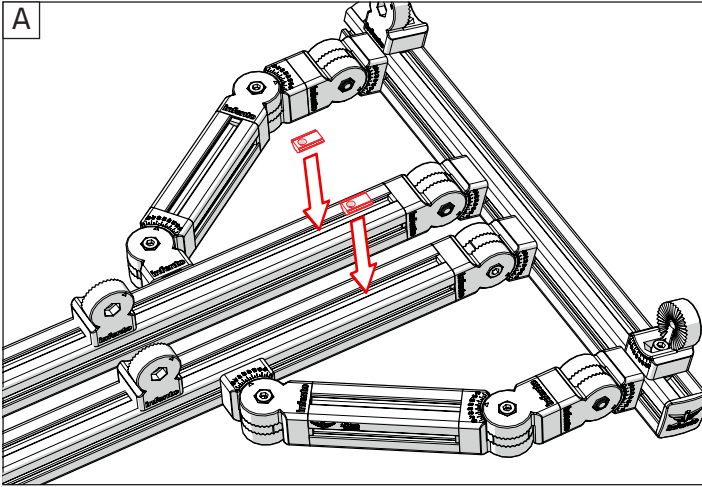



21

ride B-TRIKE

- Bolt M8x20 (low head) 1x
- T-Positioning block 2x
- Profile nut short 1x
- L-joint 1x

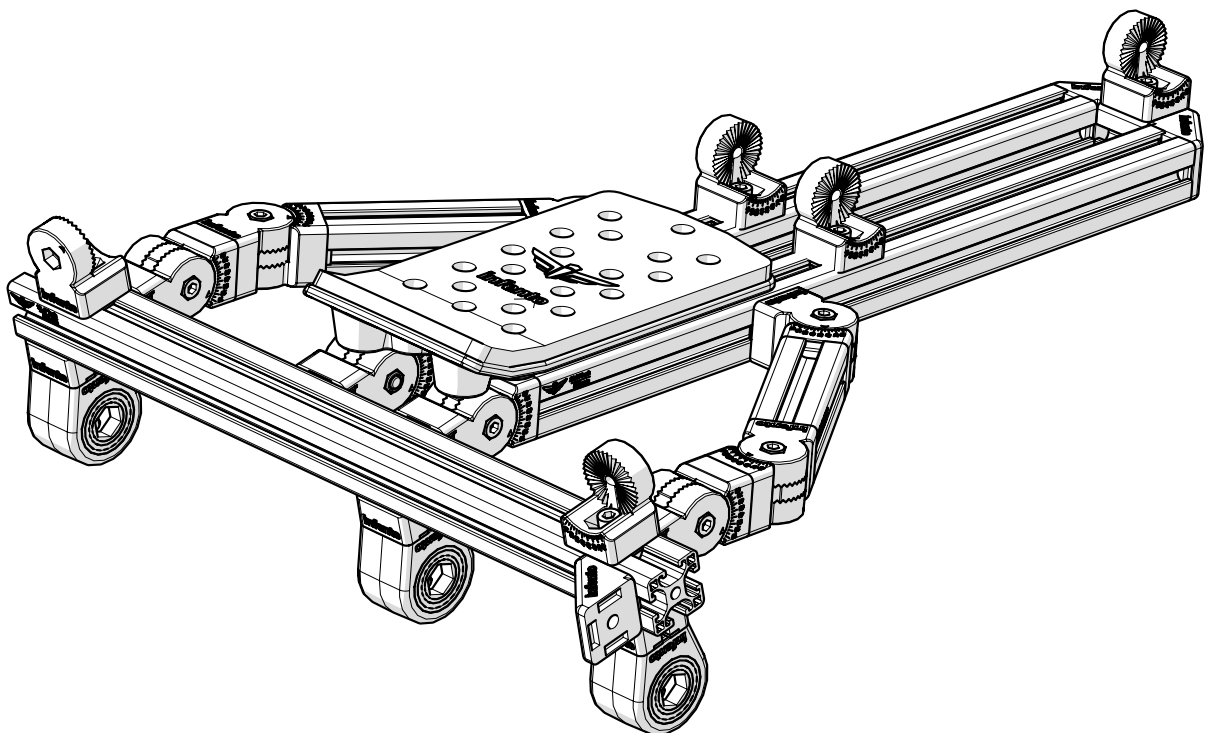
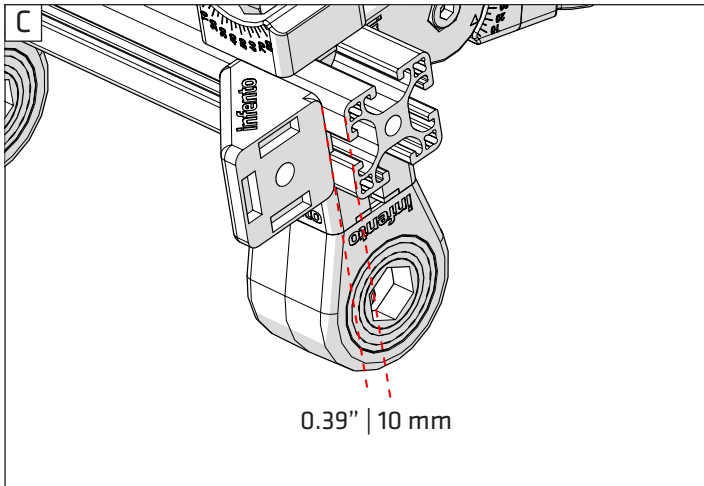
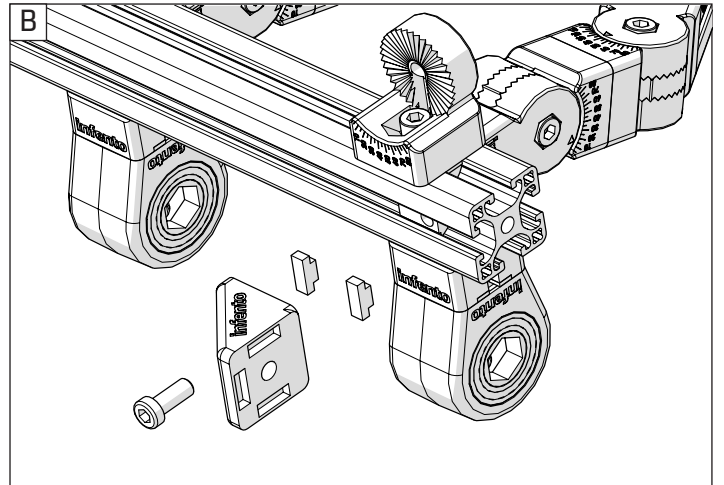
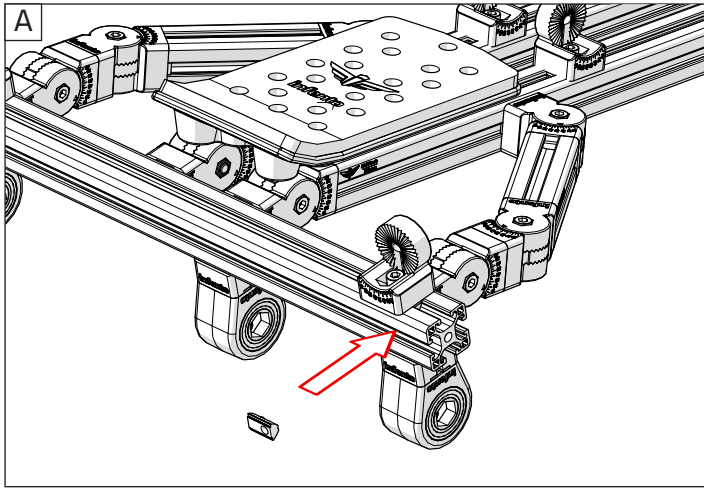



22

ride B-TRIKE



Locknut M8

1x



Bolt M8x20
(low head)

1x

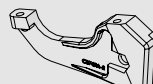

Brake caliper holder

1x



Protect cap

1x

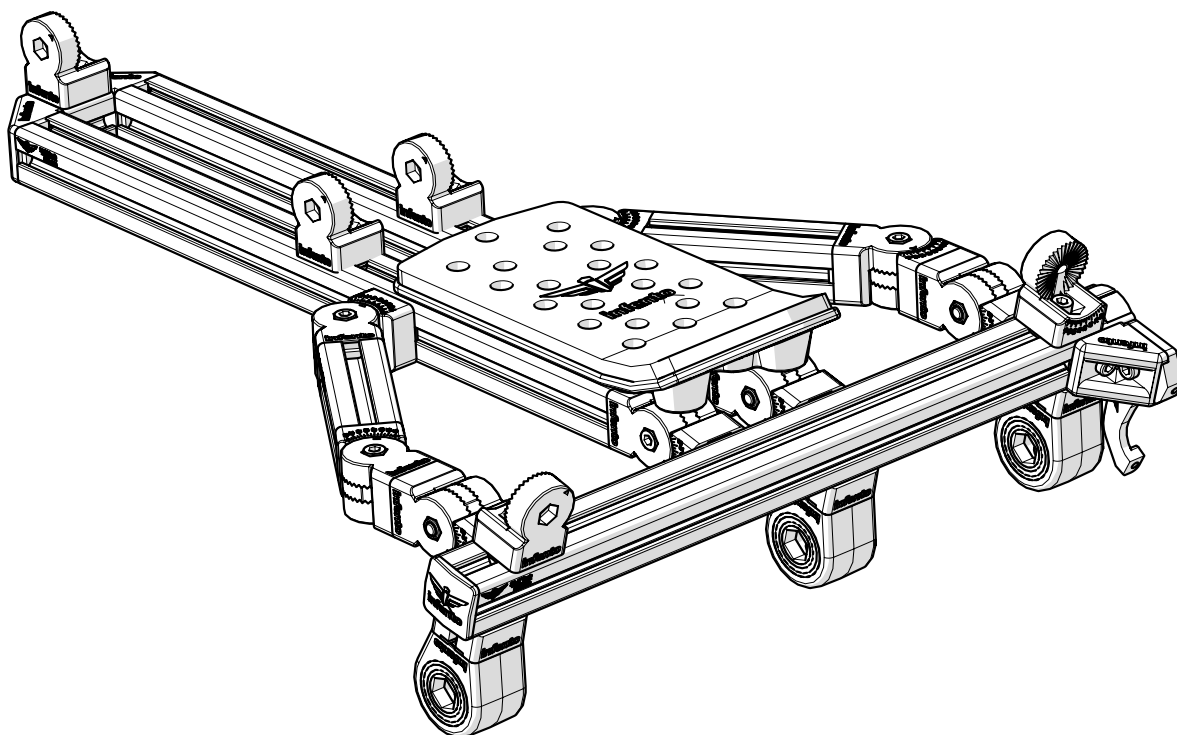
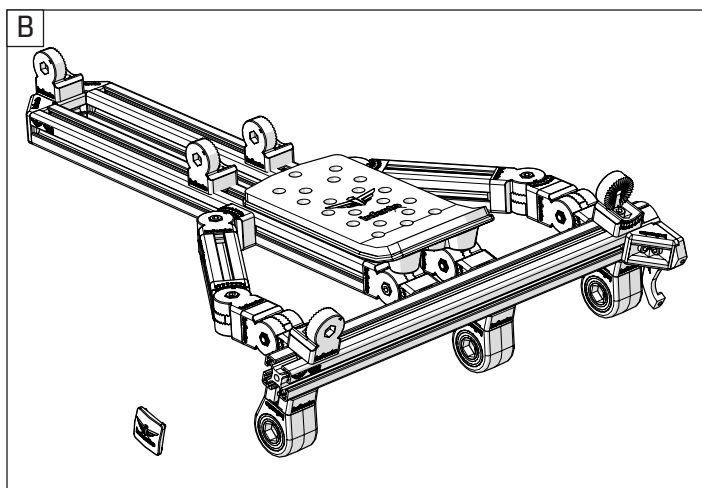
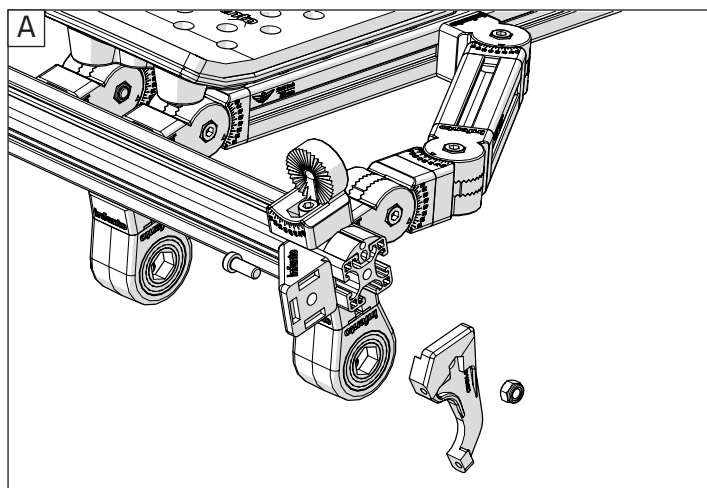



23

ride B-TRIKE



1x

Toothed belt 136T



5x

Bolt M6x16



5x

Locknut M6

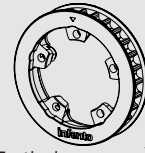

1x

Toothed belt pulley 28T

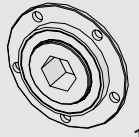

1x



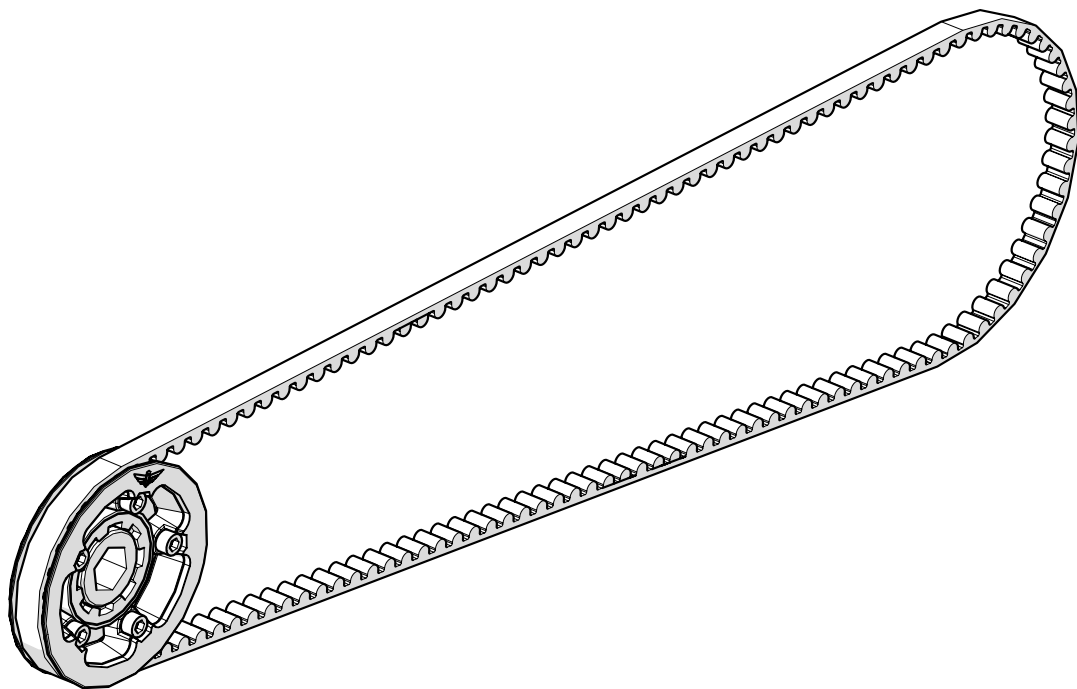
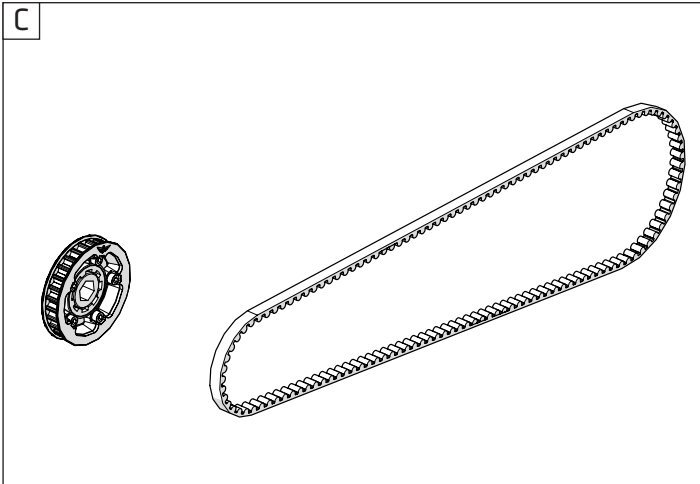
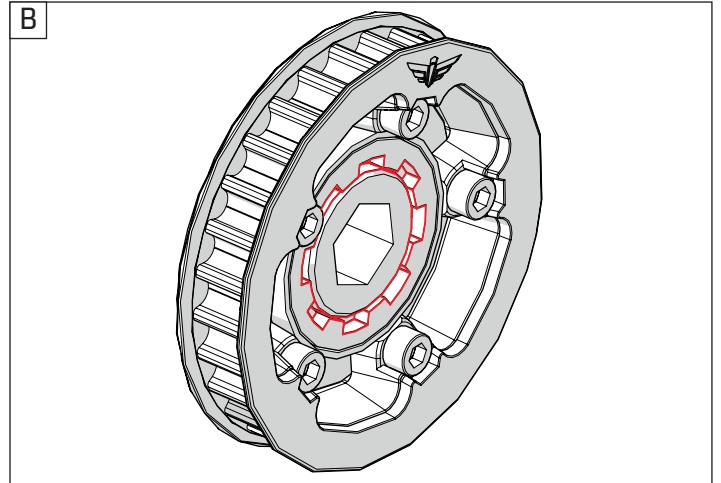
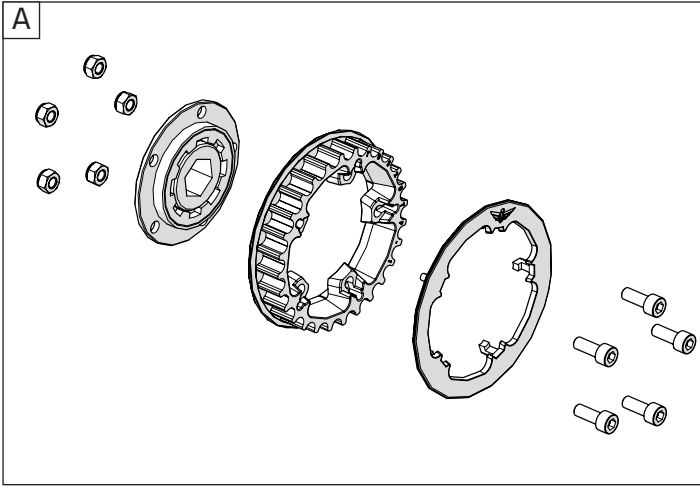

Freewheel



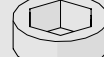

24

ride B-TRIKE

-  +  +  + 
- Spacer 1x 0.04inch | 1mm
- Spacer 1x 0.08inch | 2mm
- Spacer 2x 0.39inch | 10mm
- Axle 1x 25.51inch | 648mm

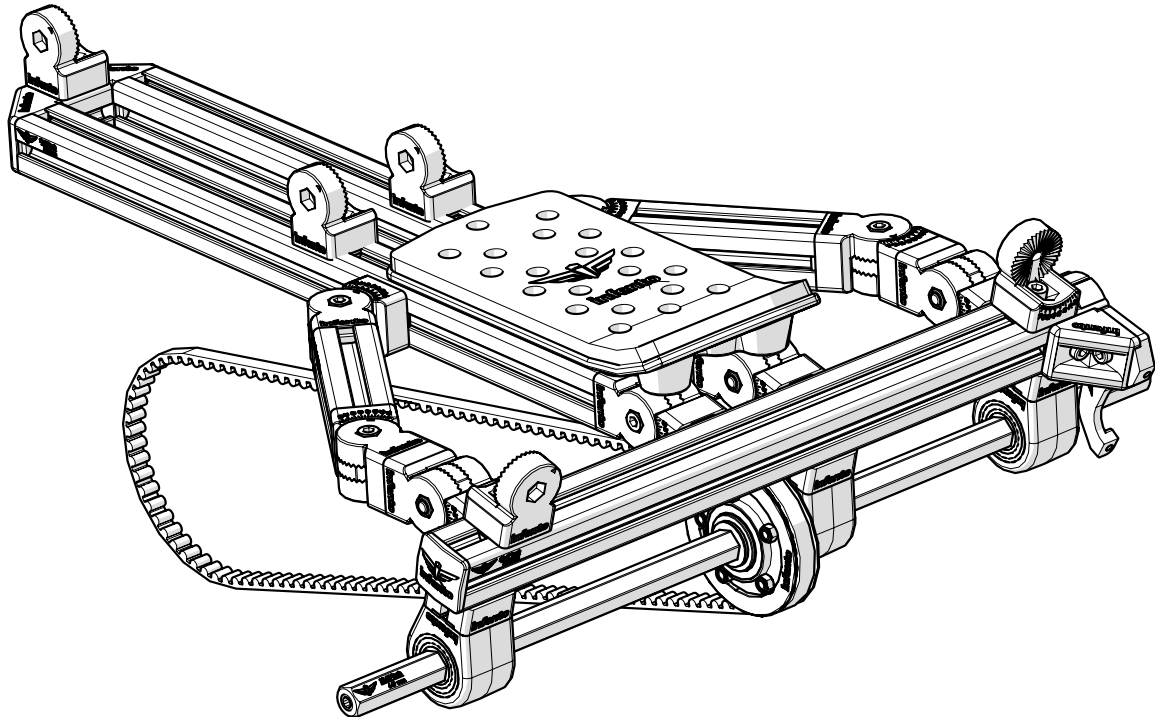
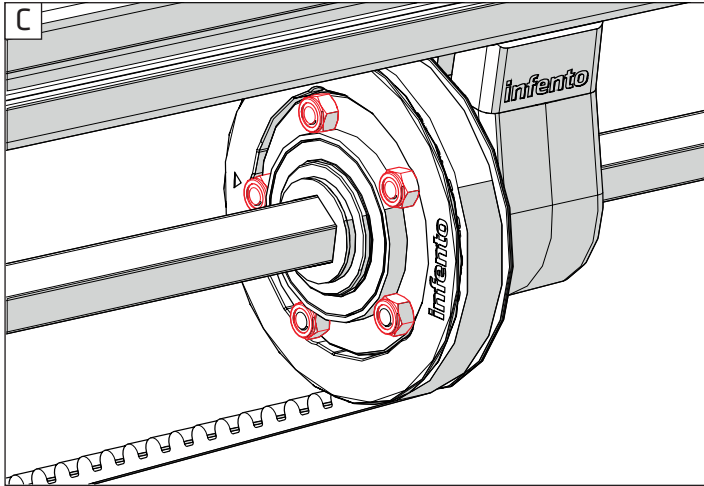
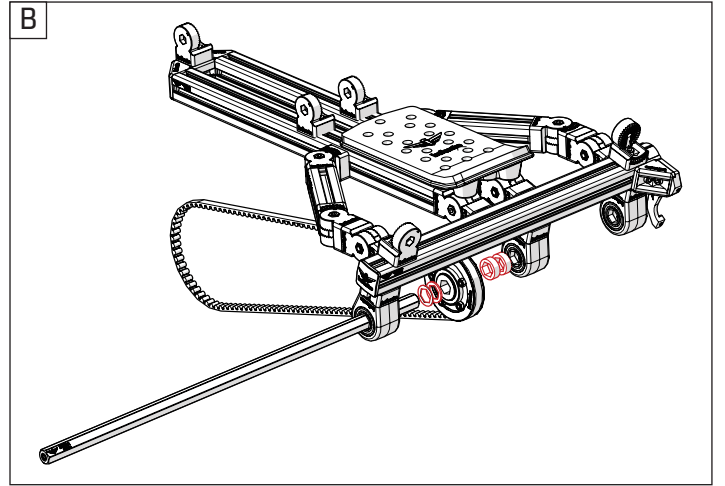
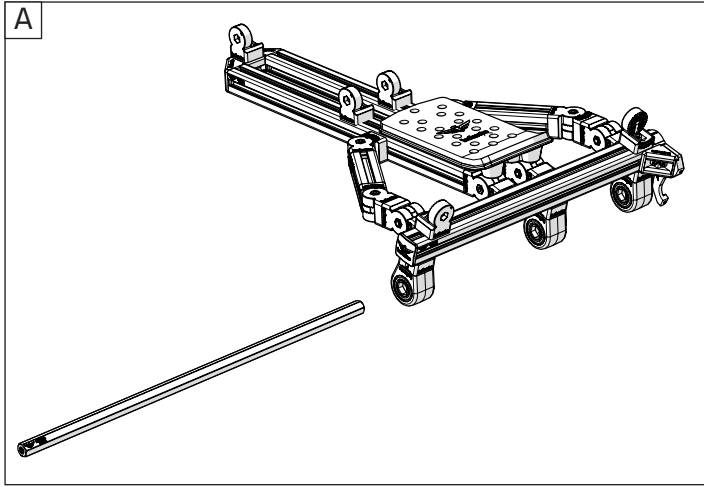



25

ride B-TRIKE

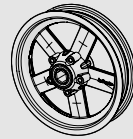

8 inch
Free spinning rim 1x

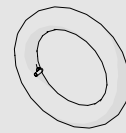

Inner tube 1x
13x2.75-8



Tire 1x
13x2.75-8

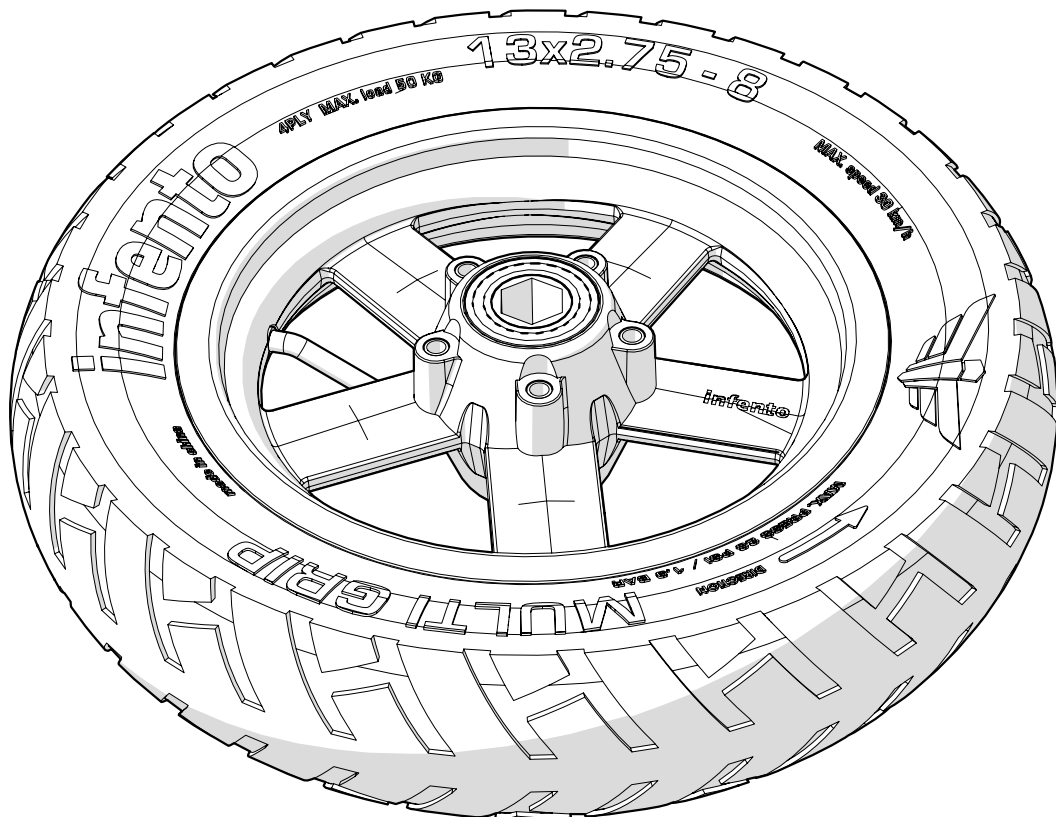
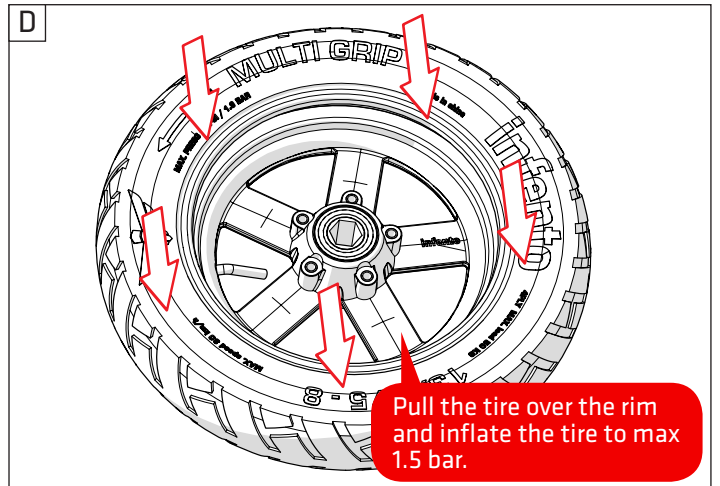
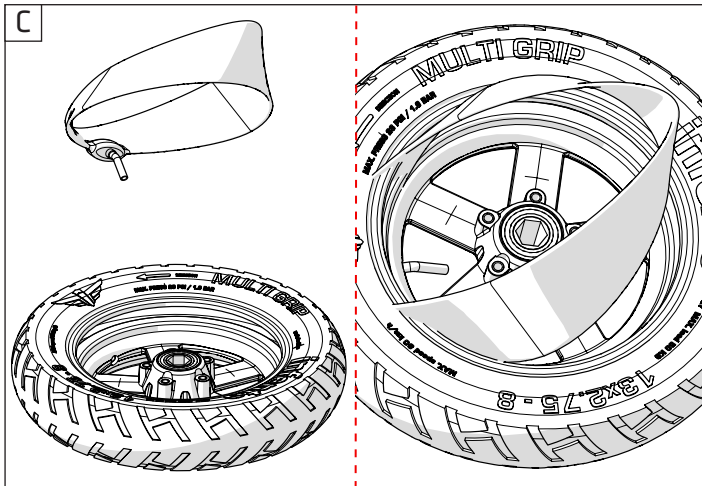
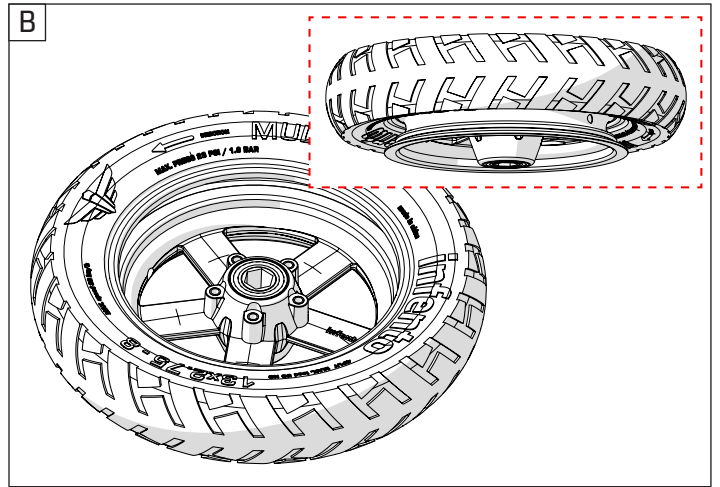
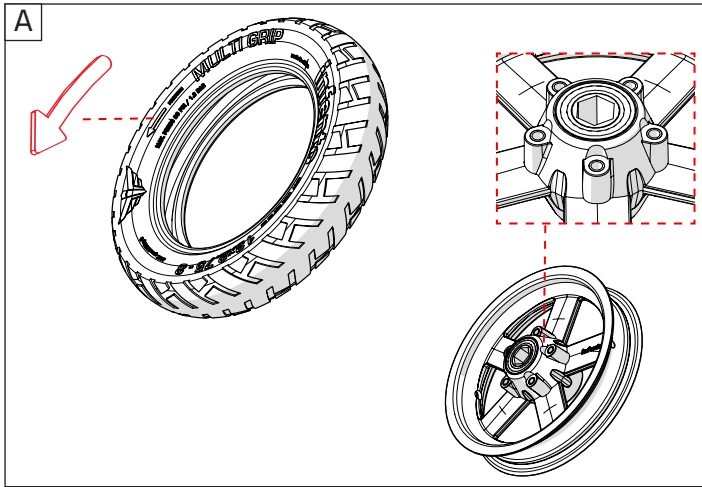



26

ride B-TRIKE



1x

Bolt M8x20

+

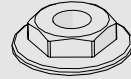

1x

Wheel lock ring

+

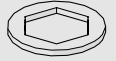

Spacer

1x

0.08inch | 2 mm

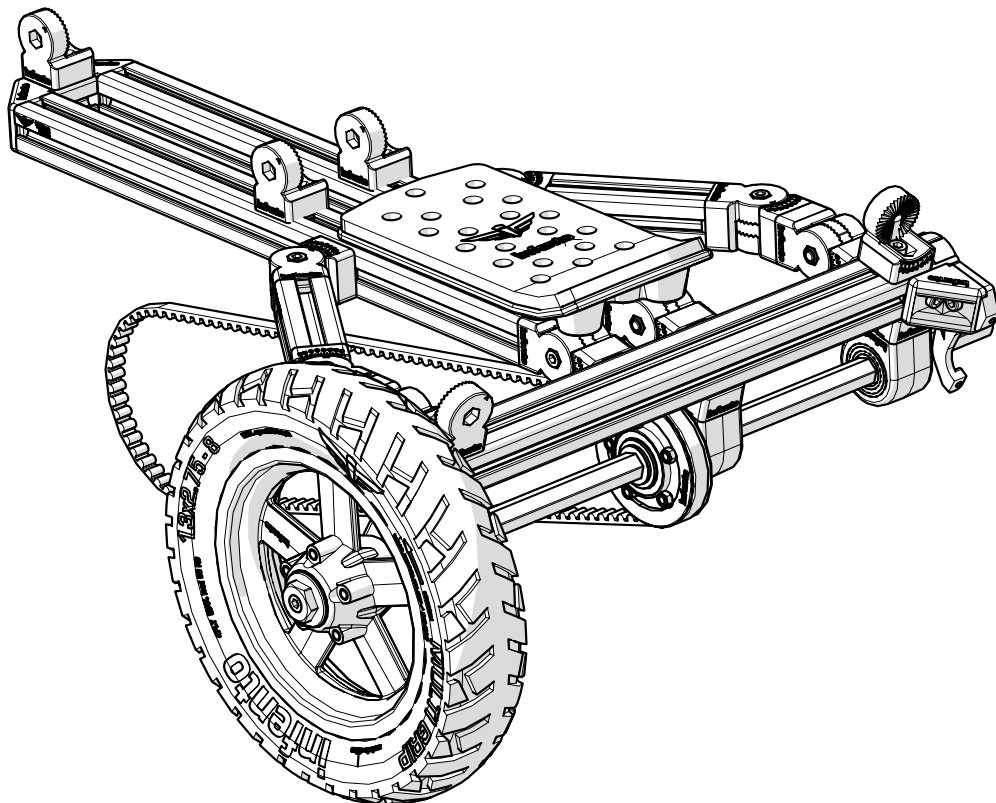
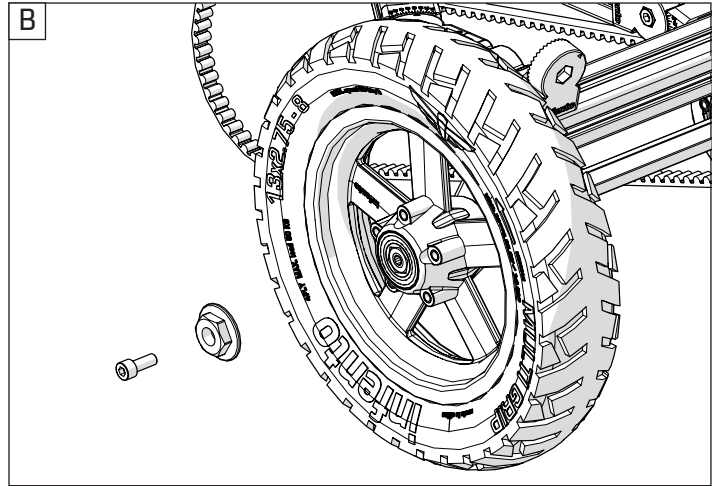
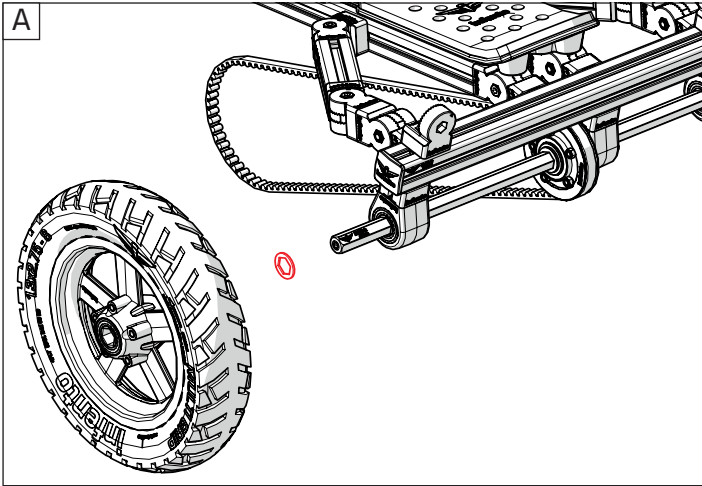



27

ride B-TRIKE

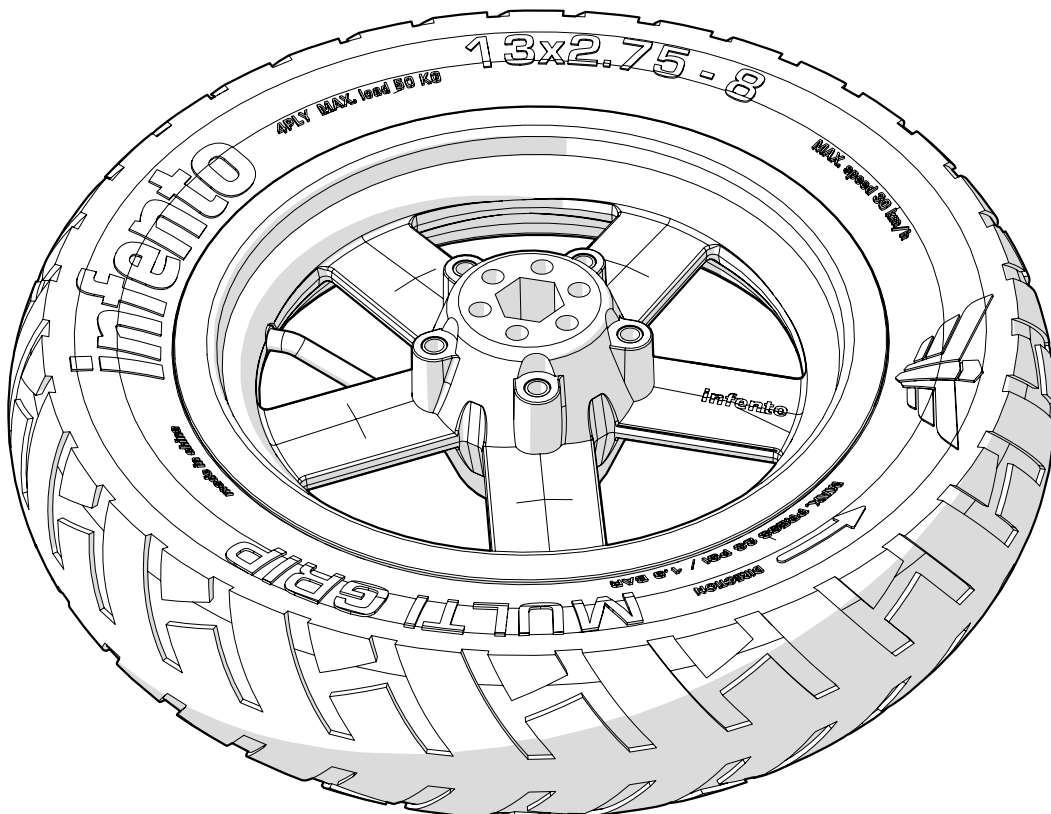
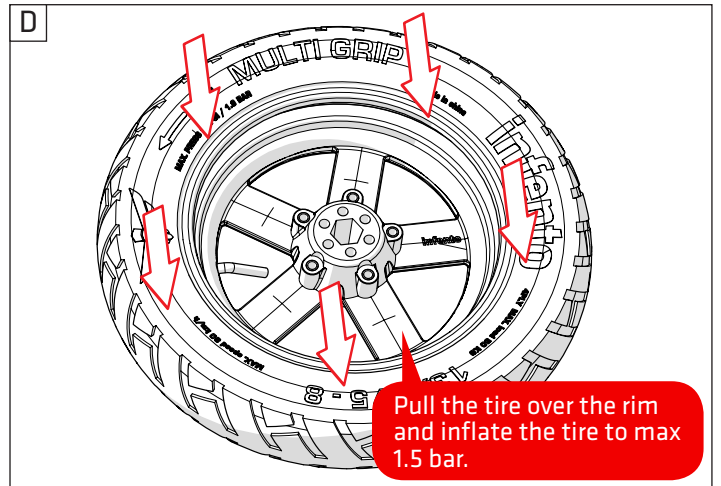
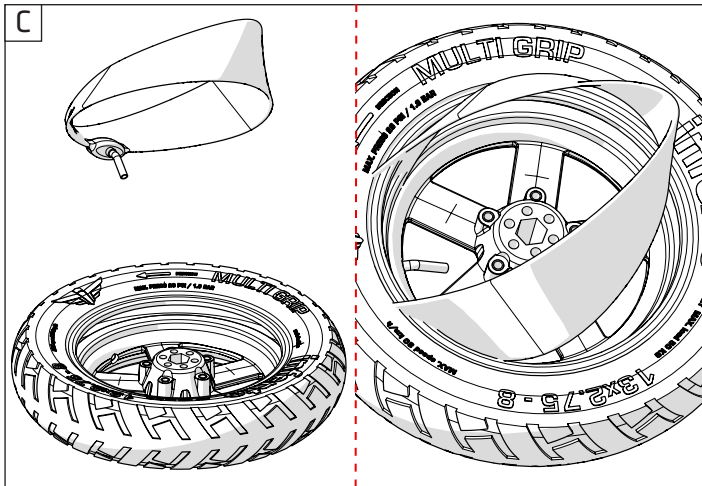
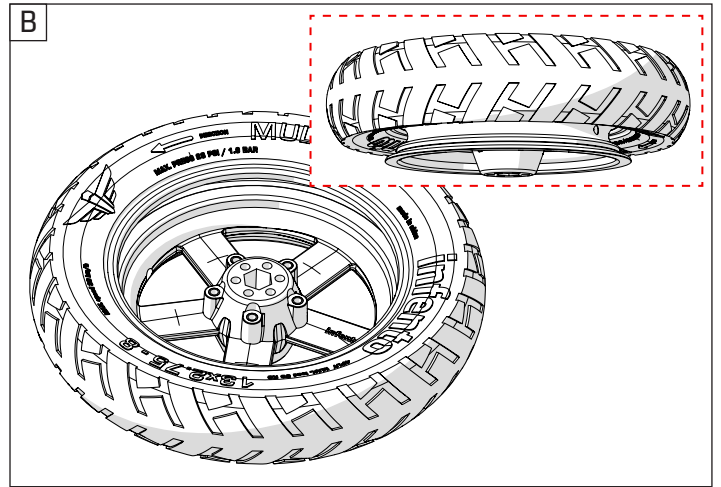
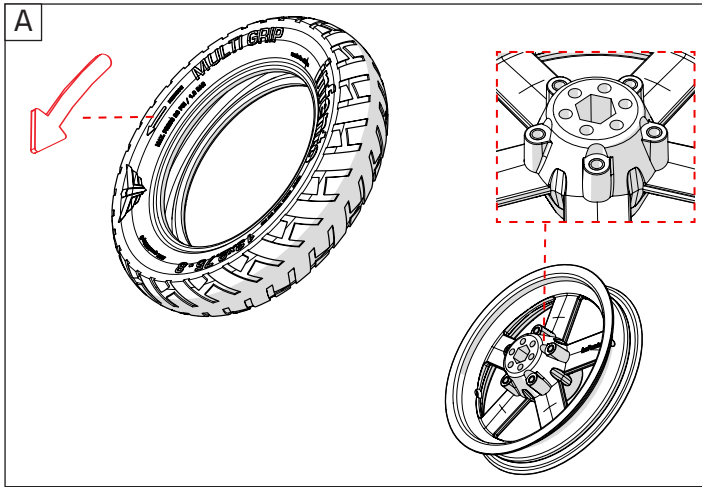



28

ride B-TRIKE

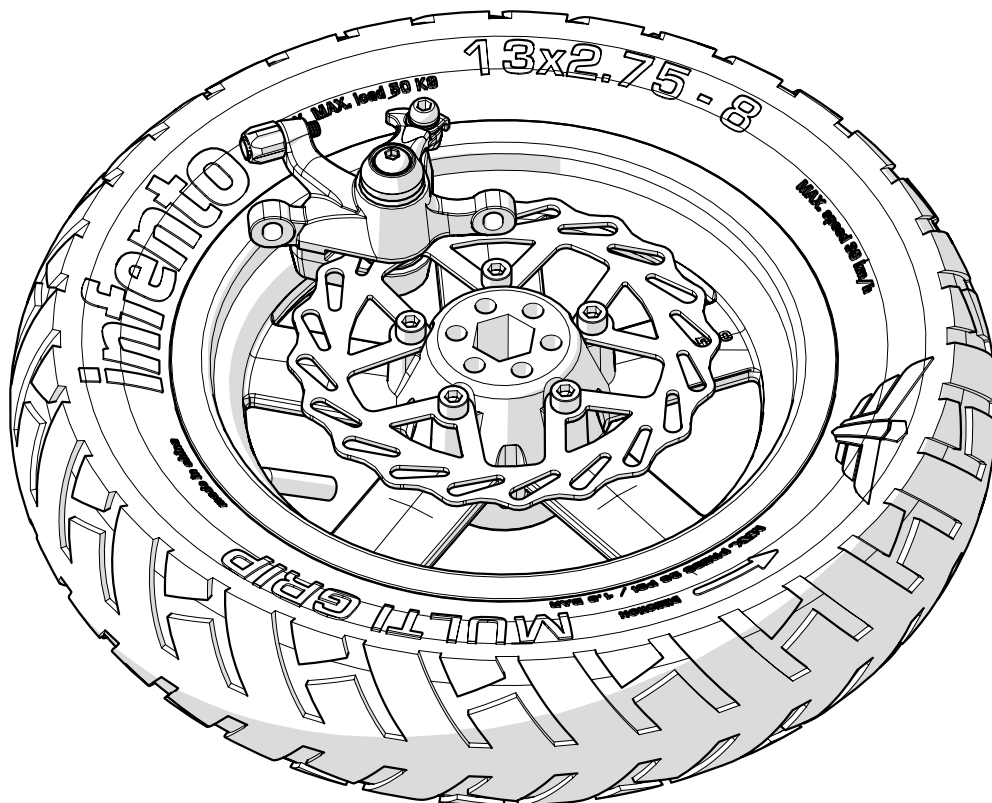
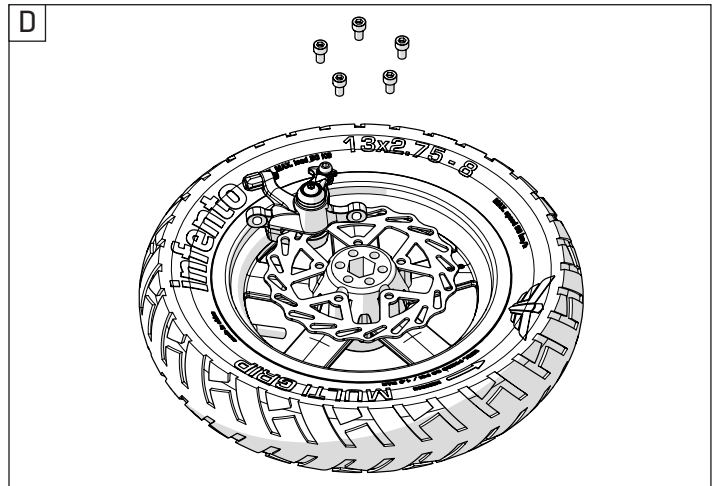
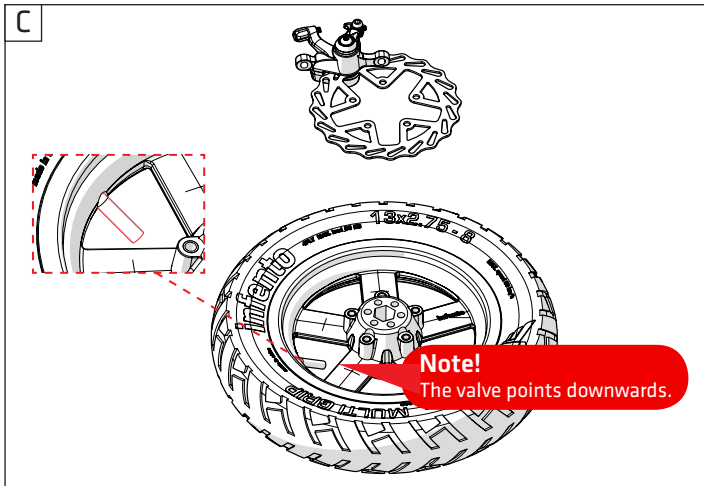
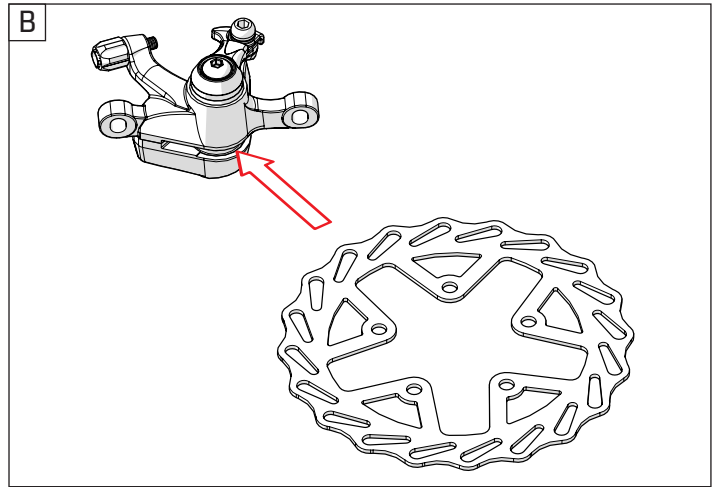
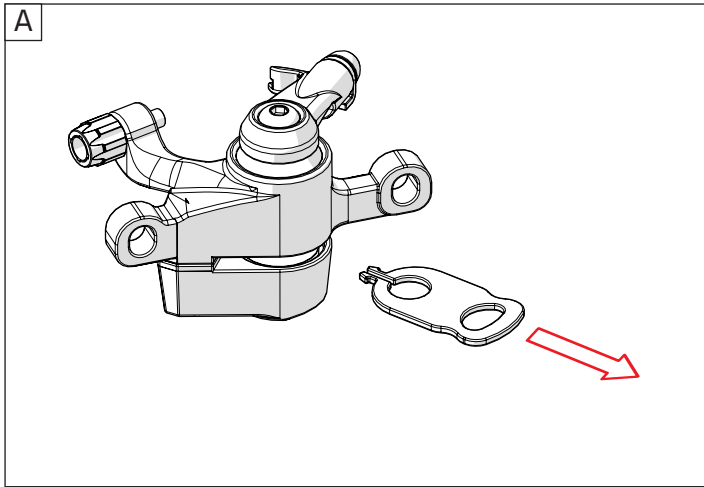
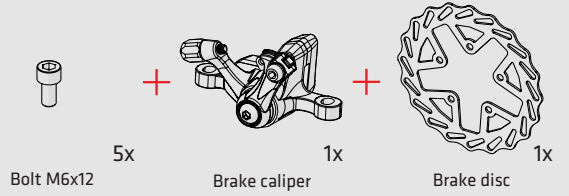



29

ride *B-TRIKE*



1x

Bolt M8x20

+

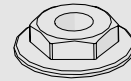

1x

Wheel lock ring

+

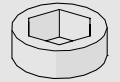

Spacer

1x

0.39inch | 10mm

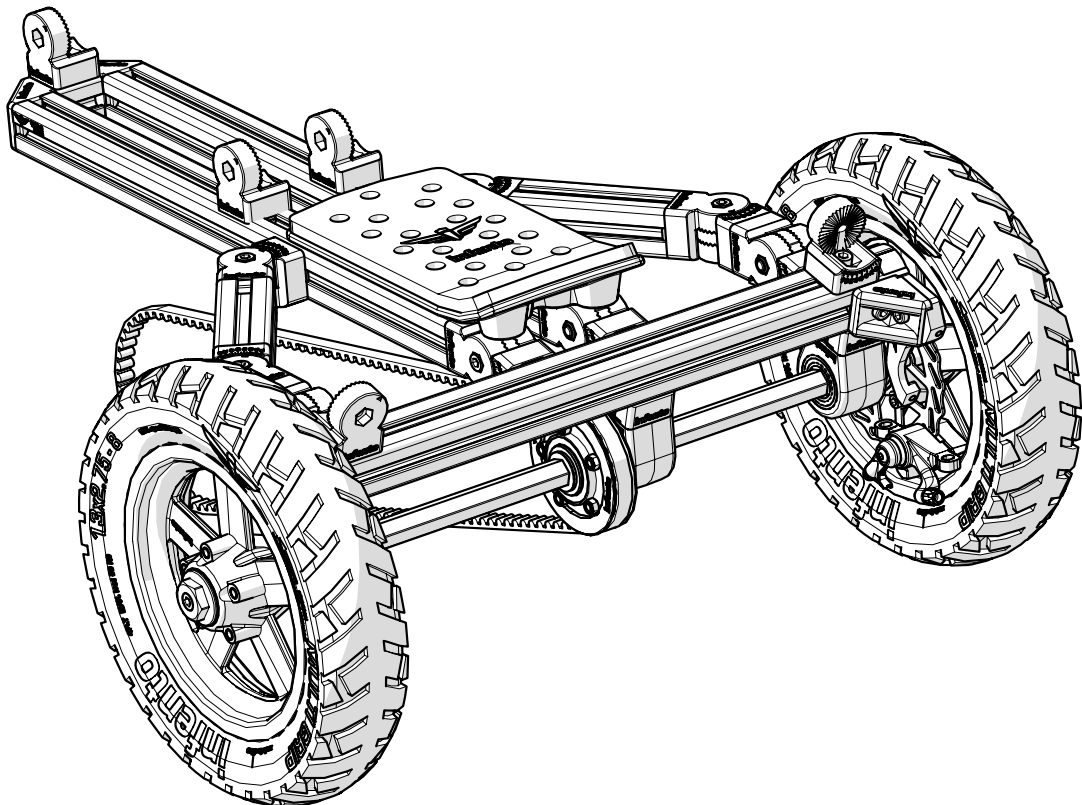
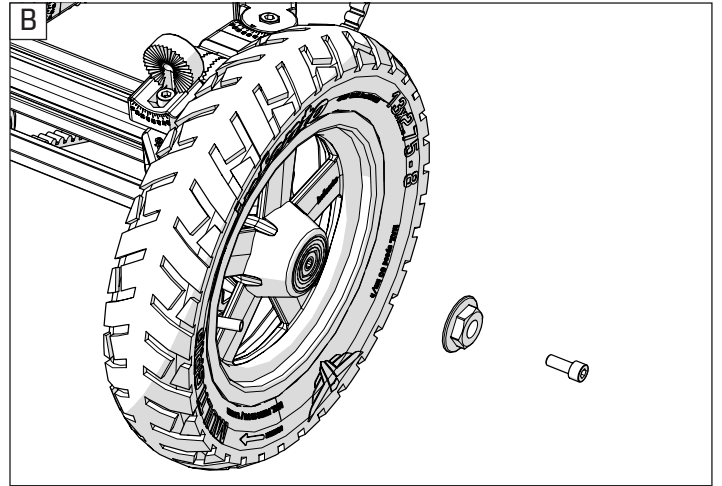
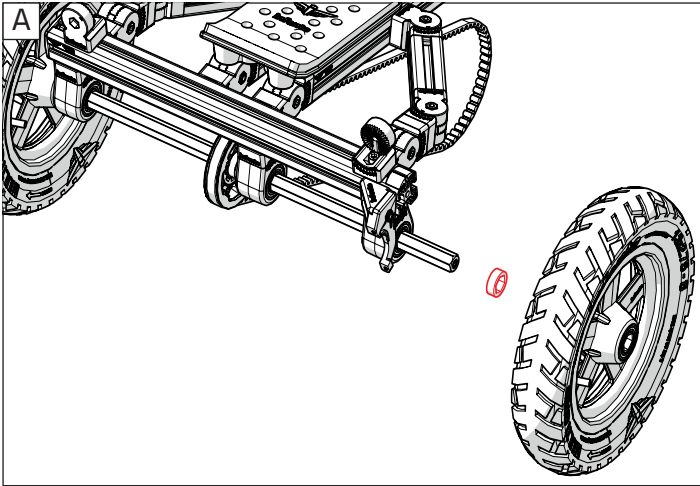



30

ride B-TRIKE



Conical spring
washer M6-10

2x

Bolt M6x16

2x

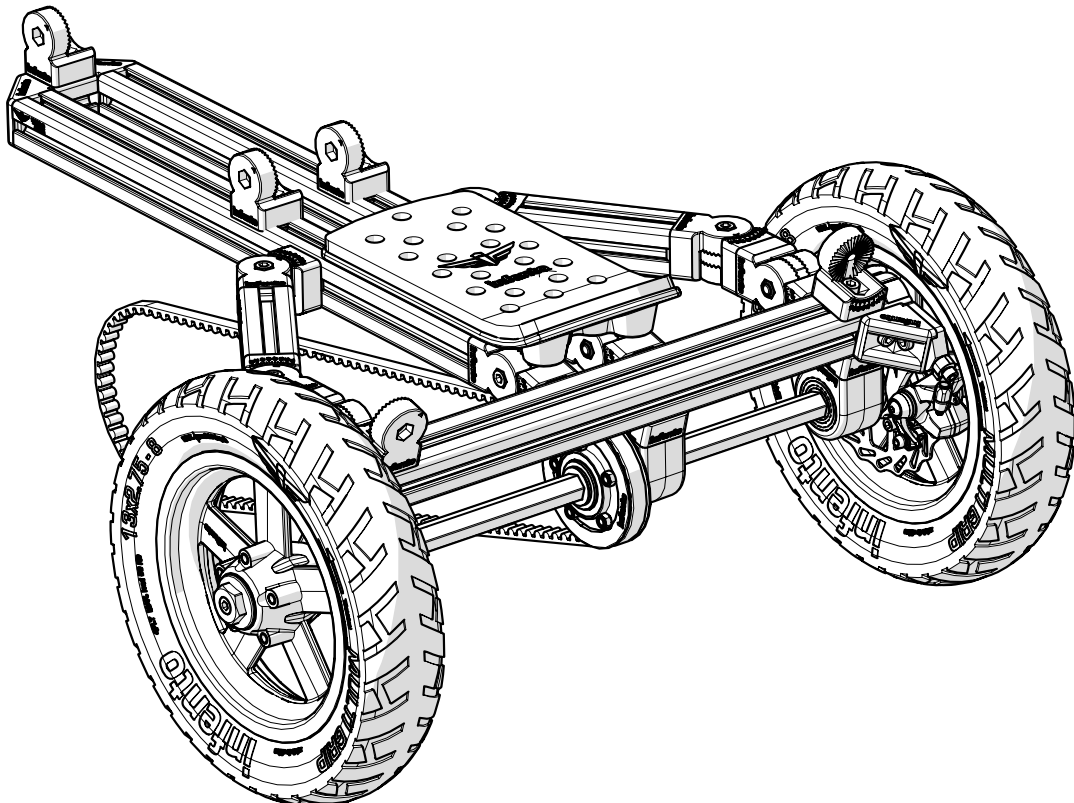
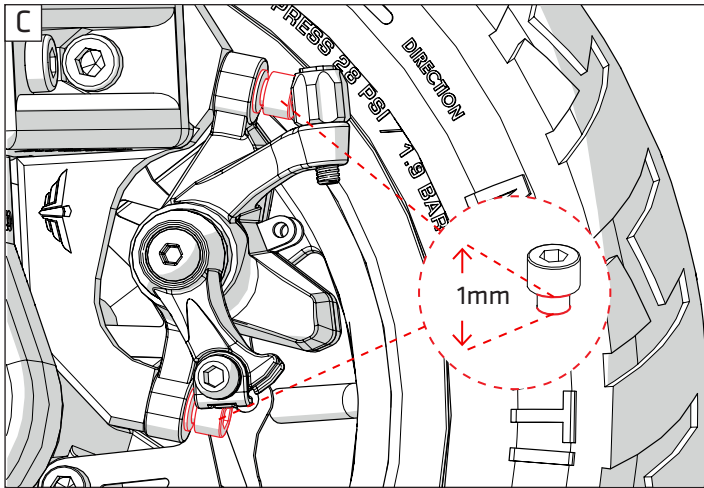
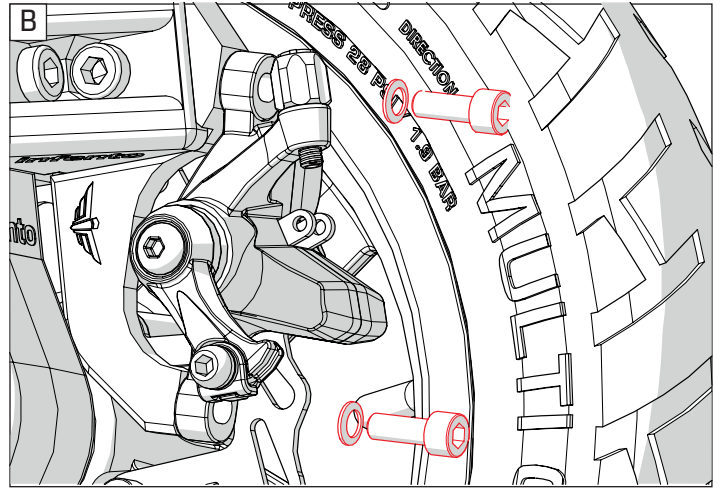
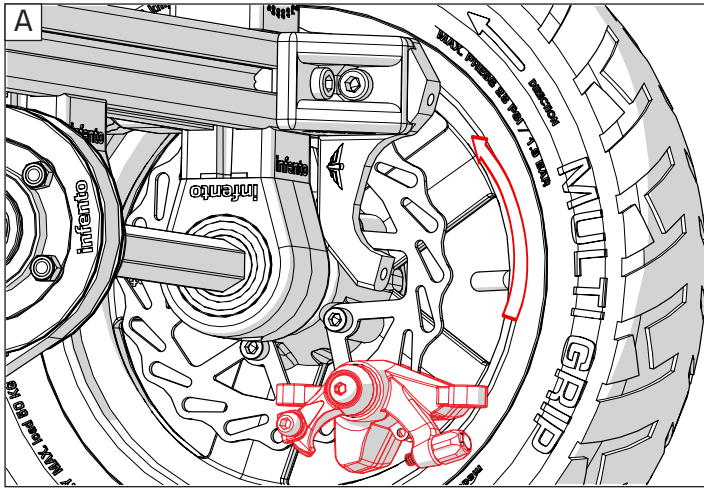



31

ride B-TRIKE

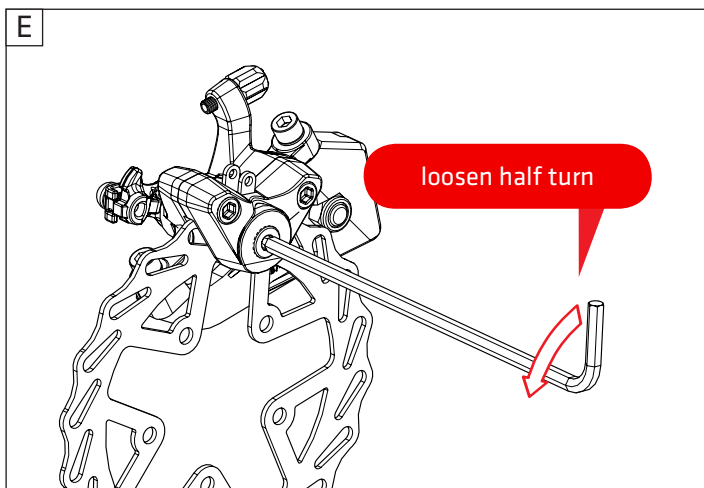
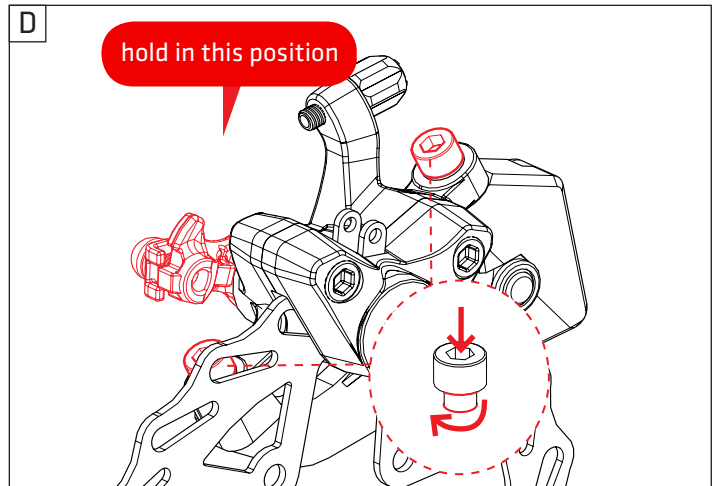
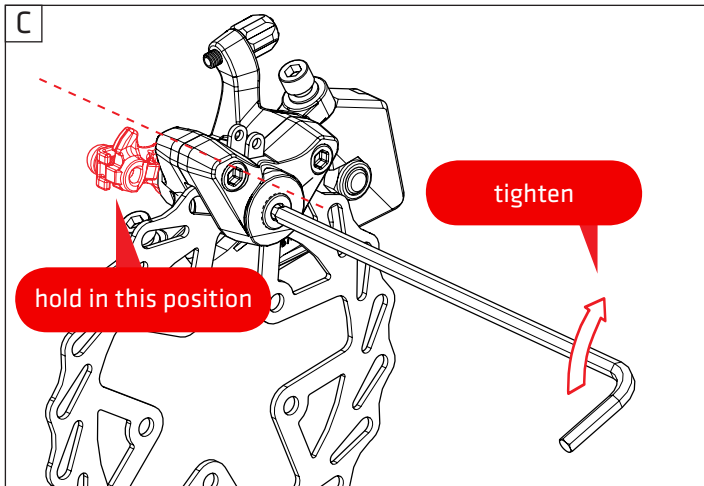
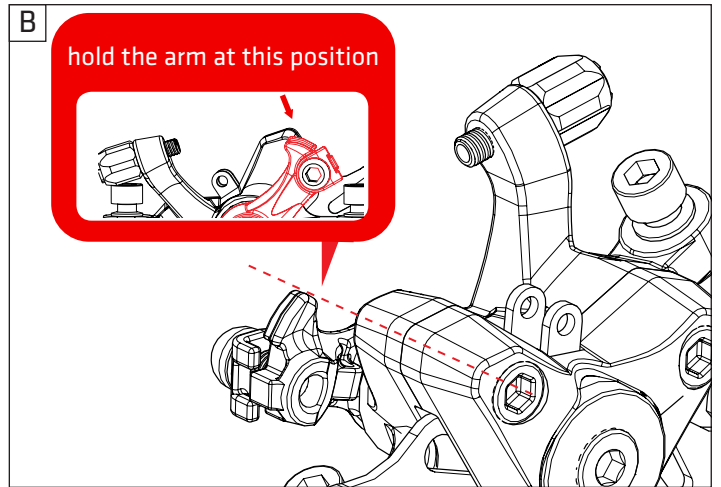
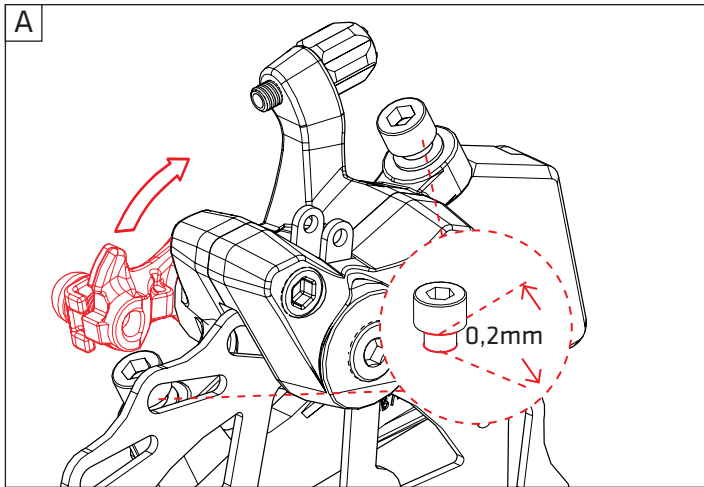



32

ride B-TRIKE



2x

Bolt M6x20

+

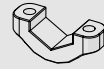

Clamping part
holes without thread

+

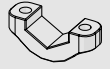

Clamping part
holes with M6 thread

1x

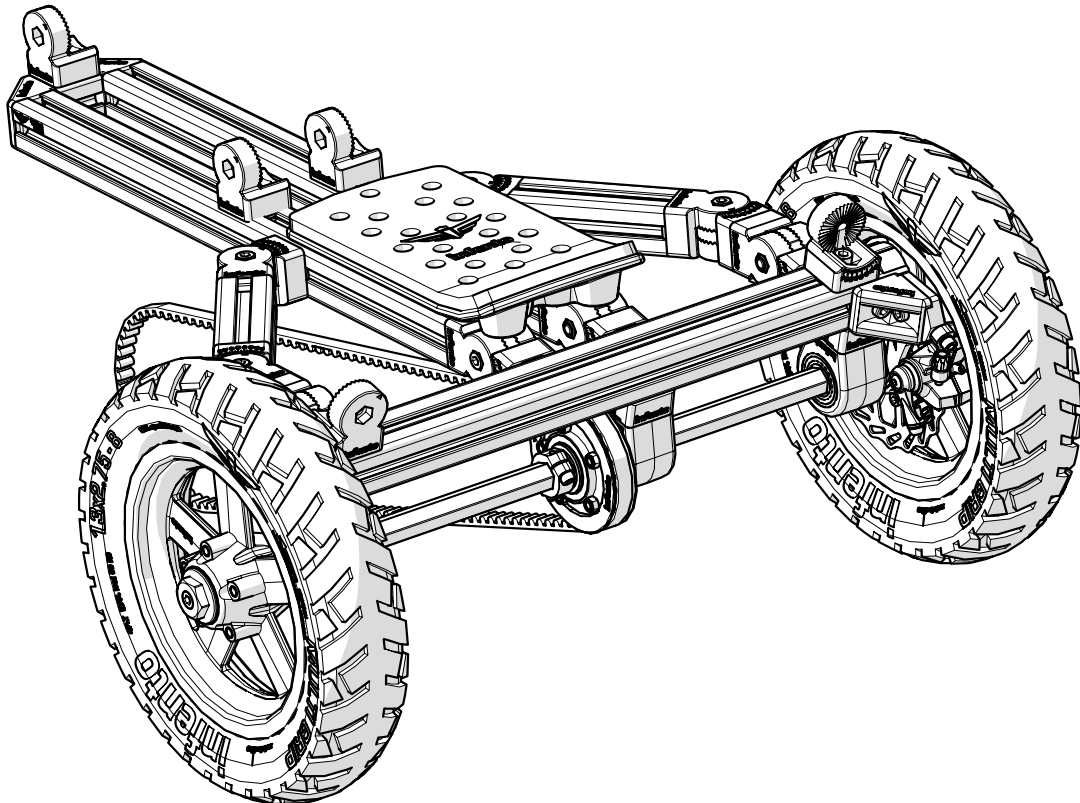
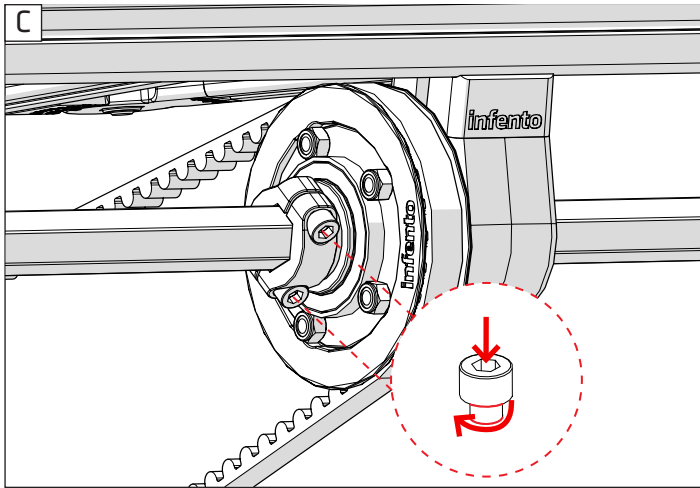
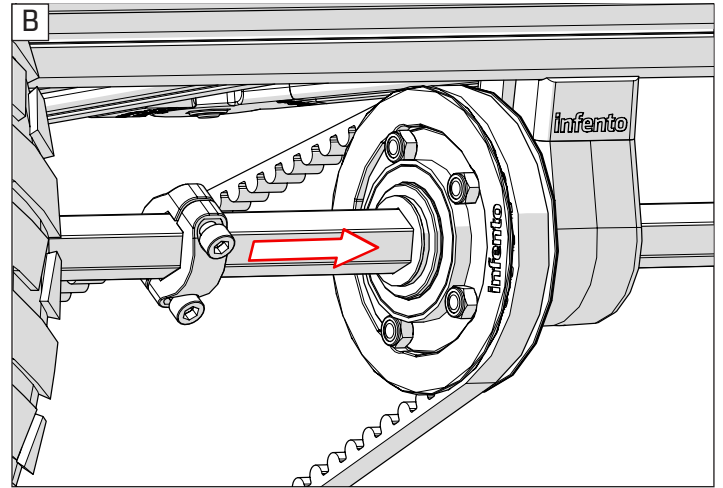
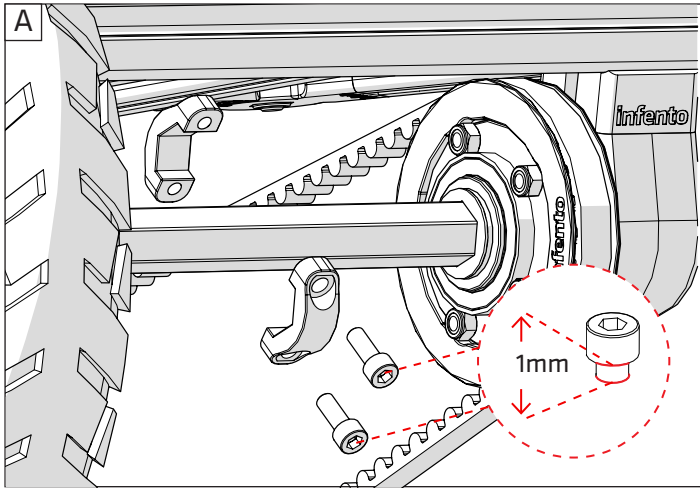



33

ride B-TRIKE

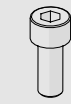

6x

Bolt M8x20

+



12x

T-Positioning block

+



6x

Multi angle joint

+

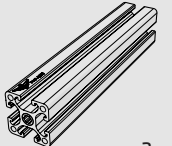

3x

Profile 5.51inch | 140mm

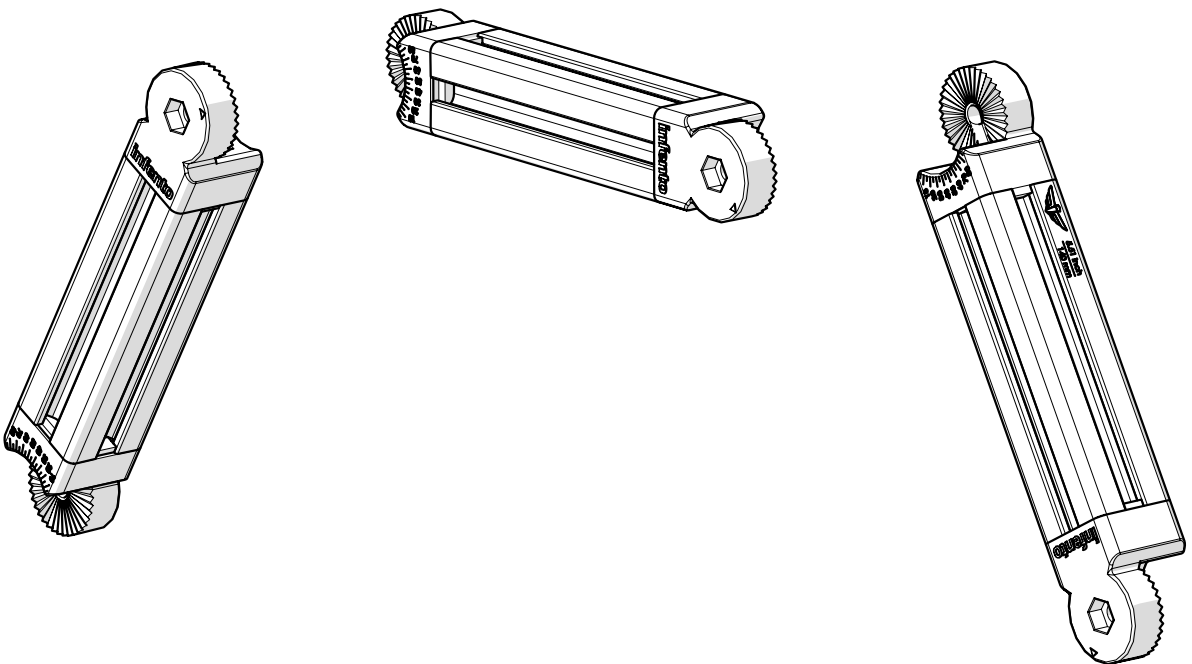
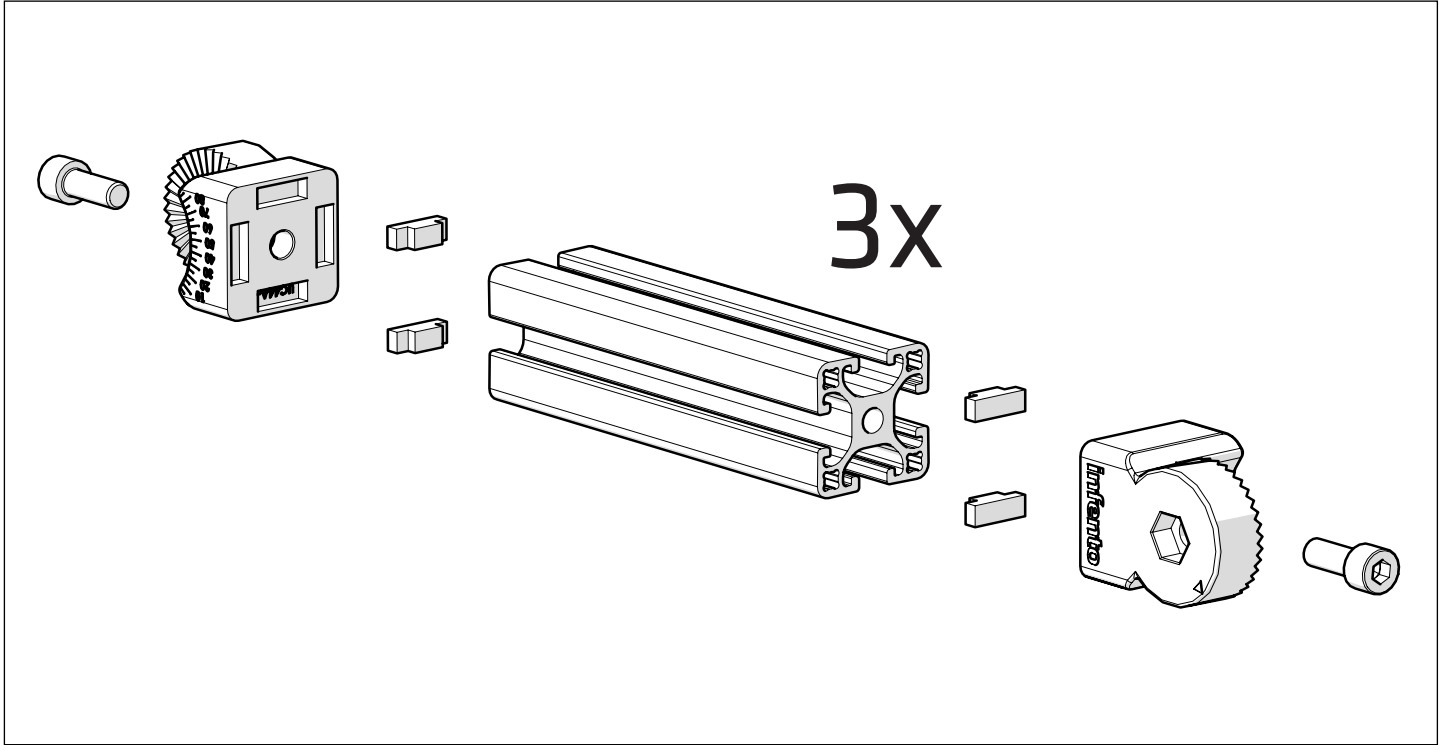



34

ride **B-TRIKE**

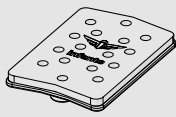

Ducktail board extension + foam 1x

+



Bolt M8x20 2x

+



Profile nut short 2x

+



Bolt M8x35 2x

+



Locknut M8 2x

+

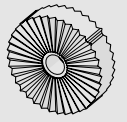

Knurled disc 2 stripes 2x

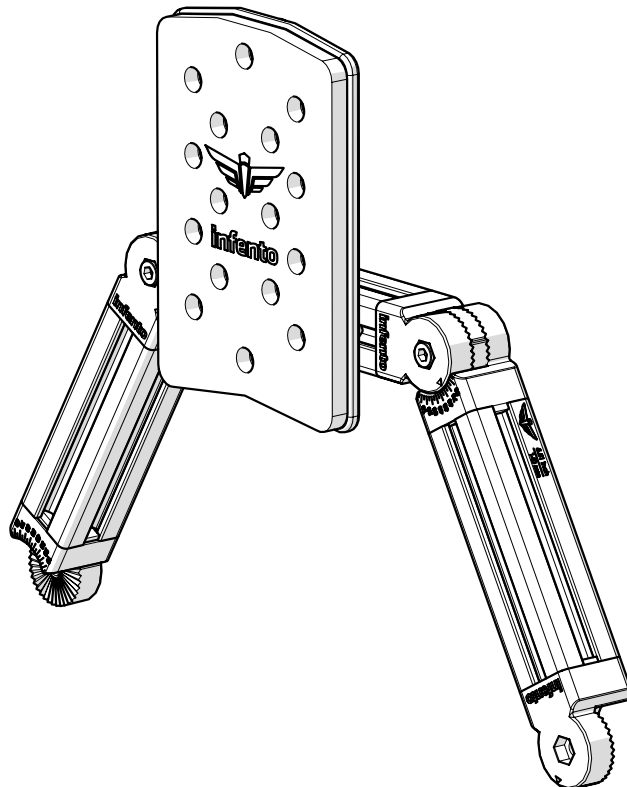
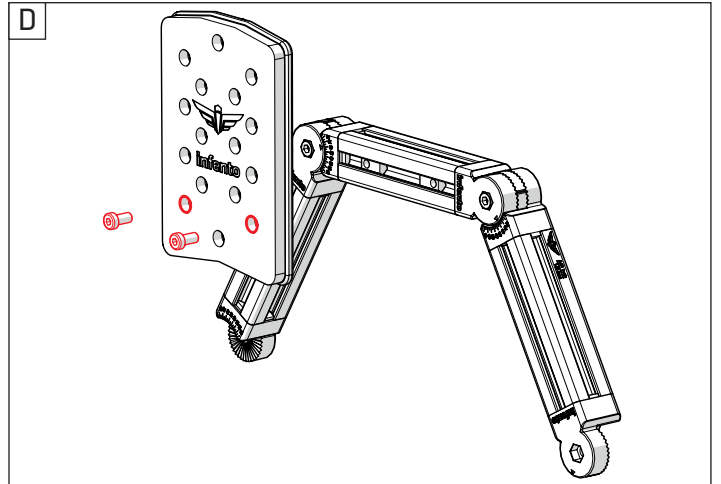
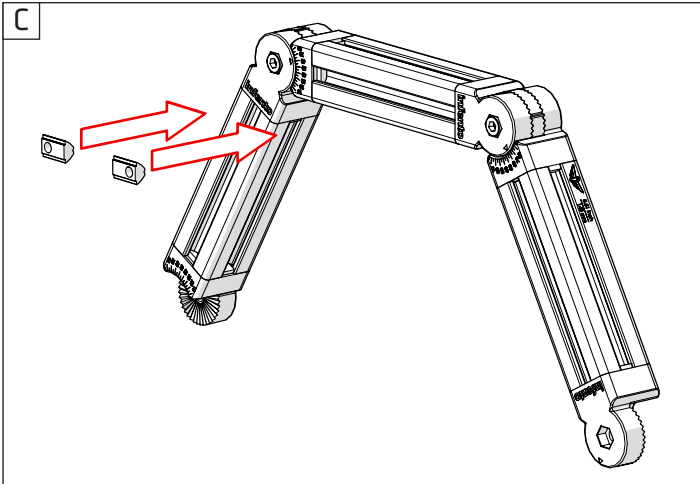
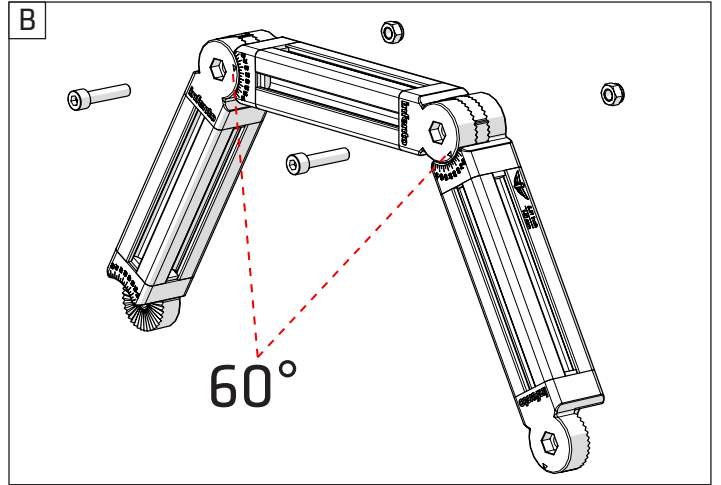
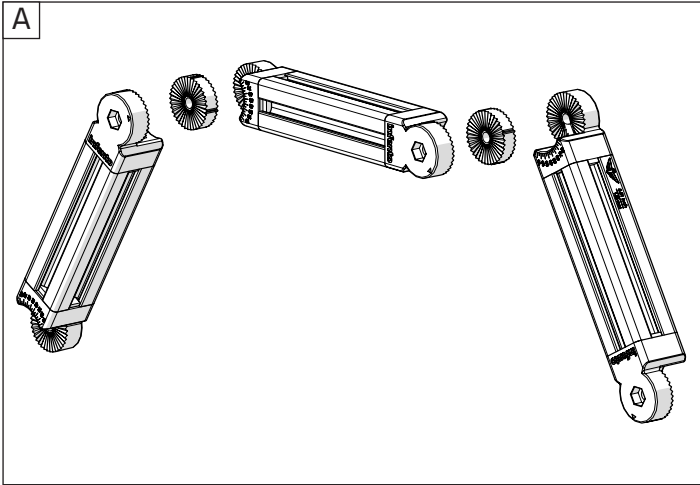



35

ride B-TRIKE



2x

Bolt M8x35

+



2x

Locknut M8

+

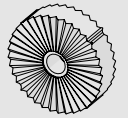

2x

Knurled disc 2 stripes

A

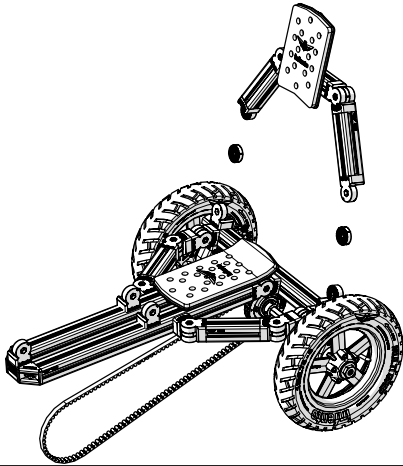

B

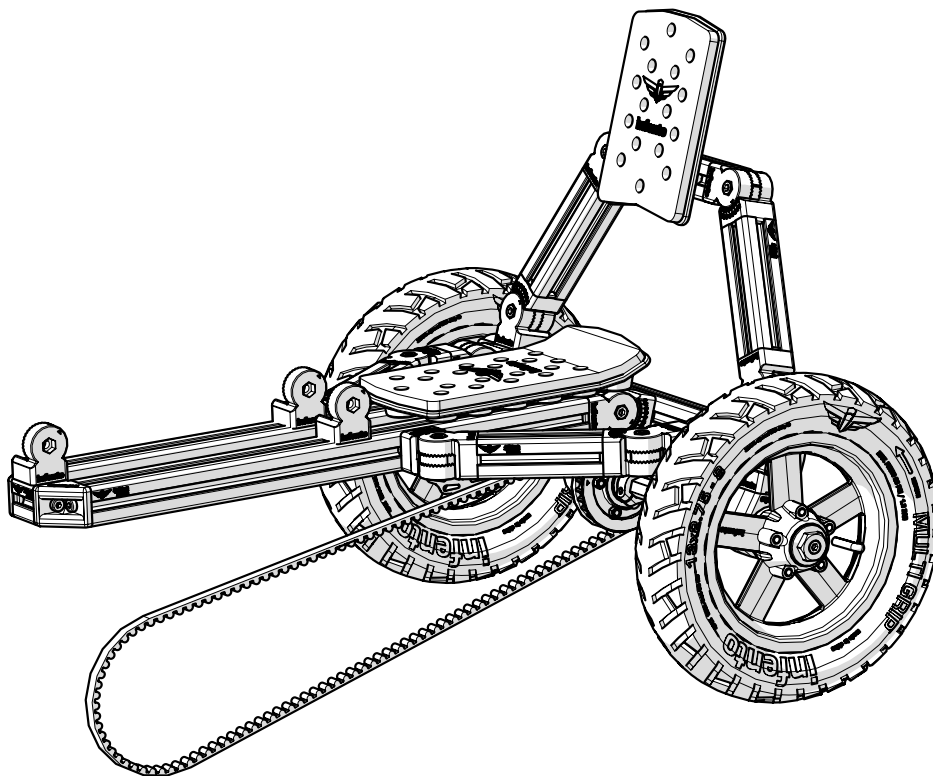
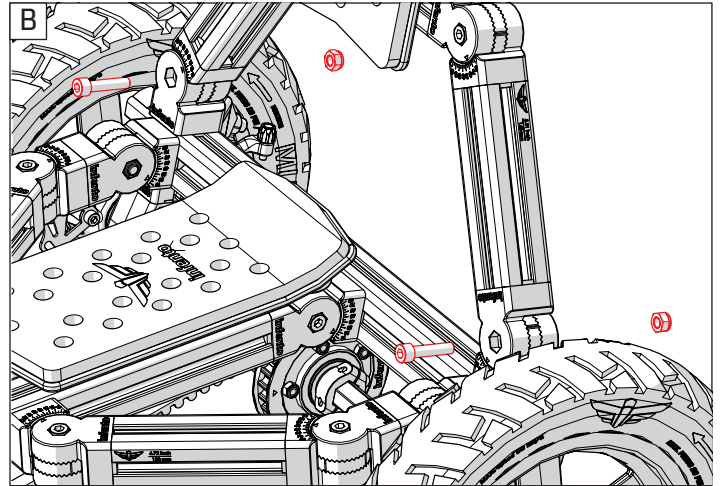



36

ride B-TRIKE



Locknut M8

2x



Bolt M8x25
(low head)

2x



Positioning block

4x

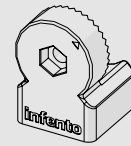

Multi angle joint

2x



L-joint

2x

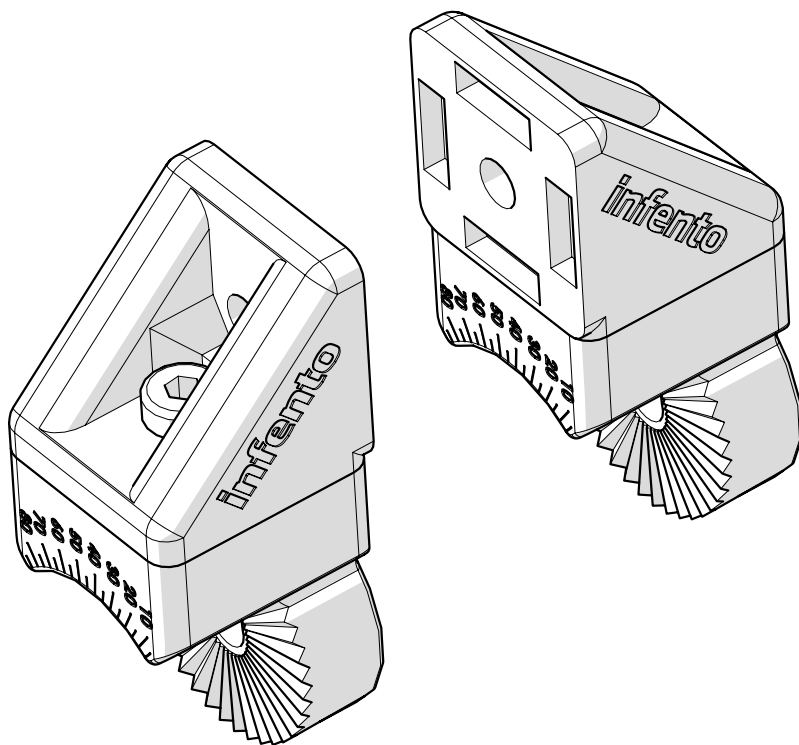
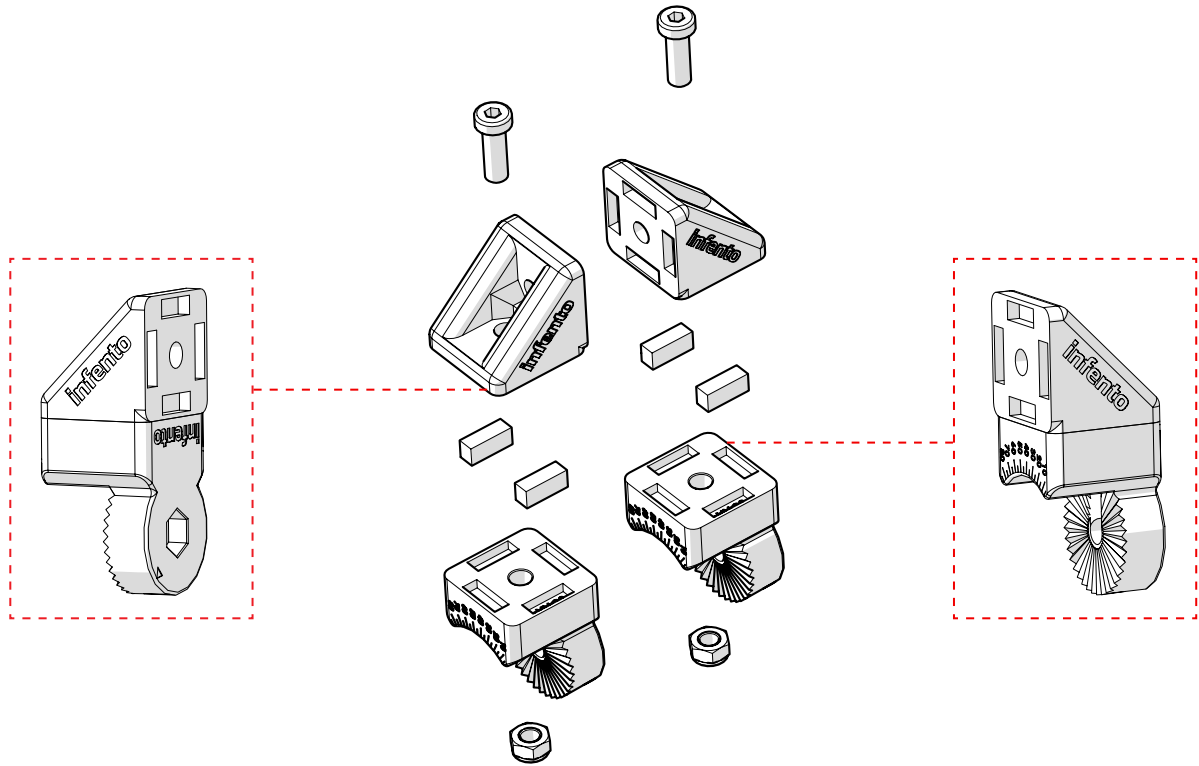



37

ride **B-TRIKE**



Protect cap 1x



T-Positioning block 4x



Bolt M8x20 (low head) 2x



Profile nut short 2x

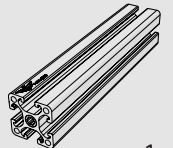

Profile 1x
9.45inch | 240mm

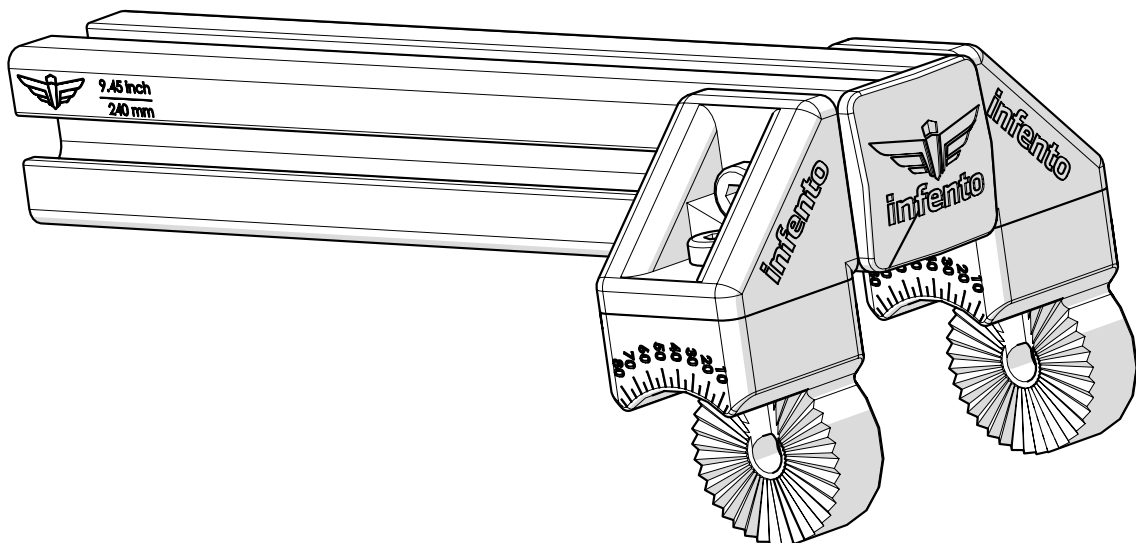
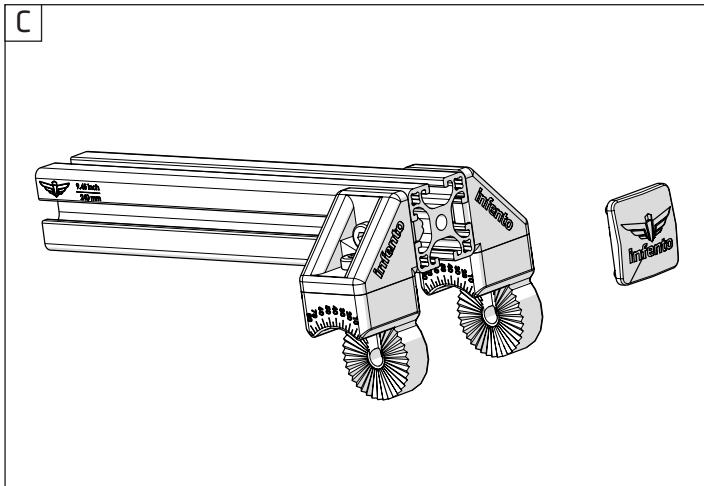
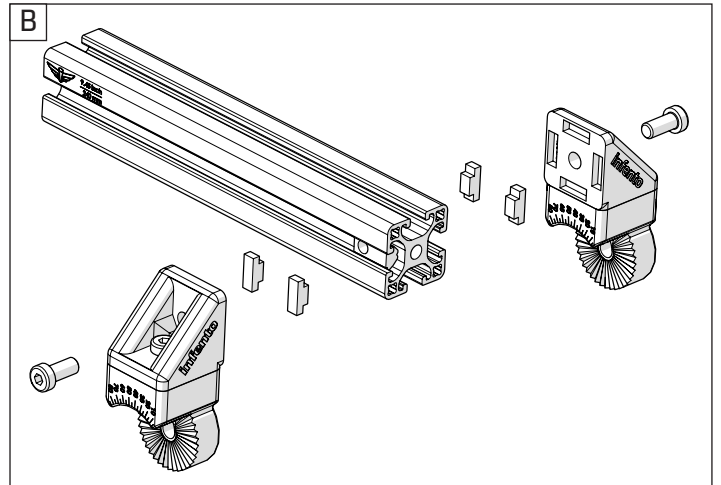
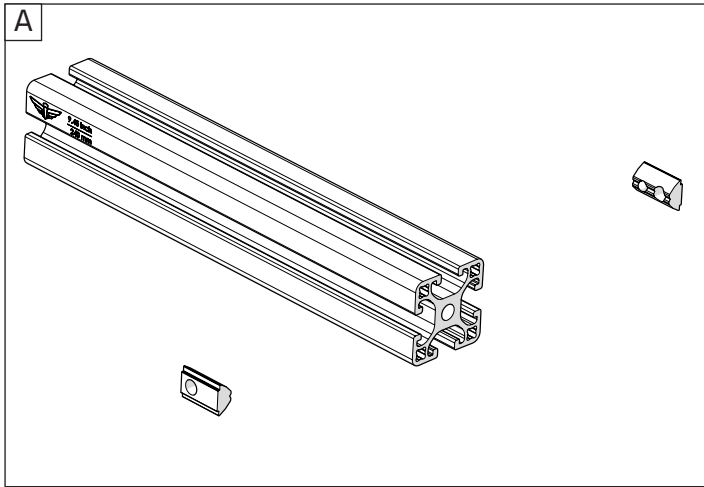





38

ride B-TRIKE



Bearing block
40x40_8 2x

T-Positioning block 4x

Bolt M8x20 2x

Profile nut short 2x

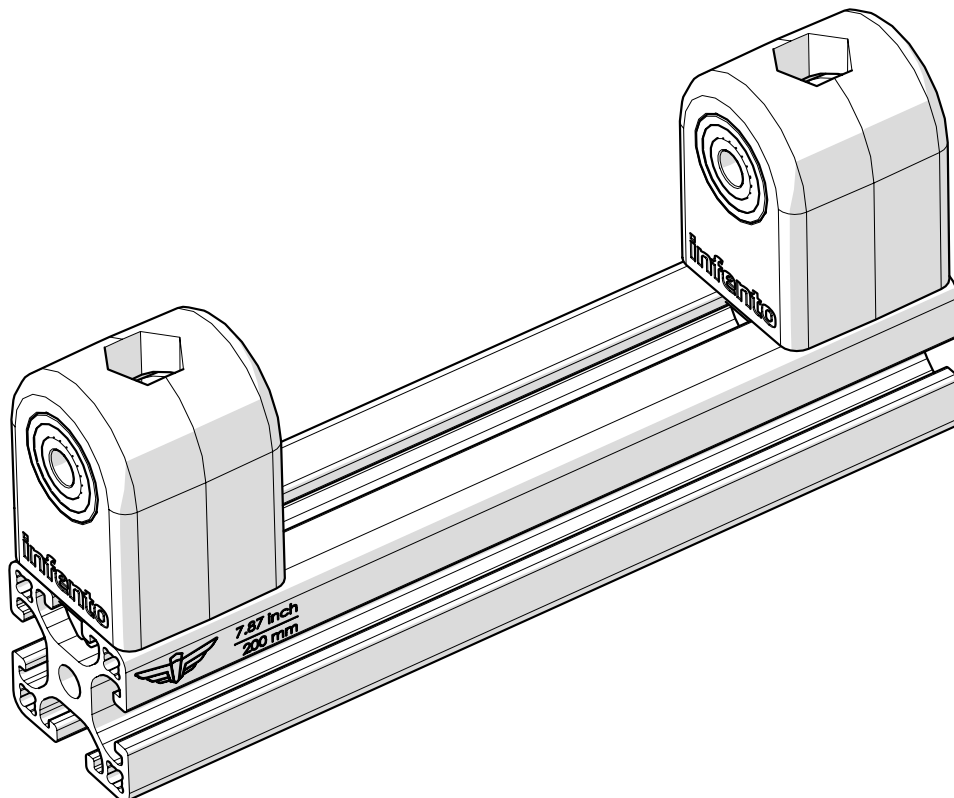
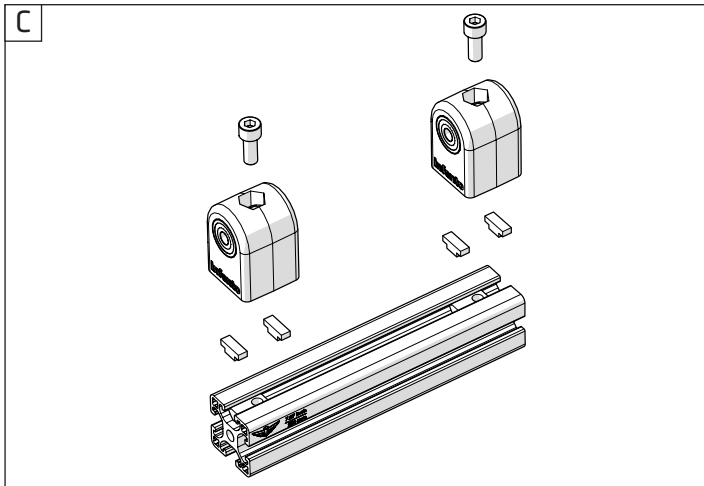
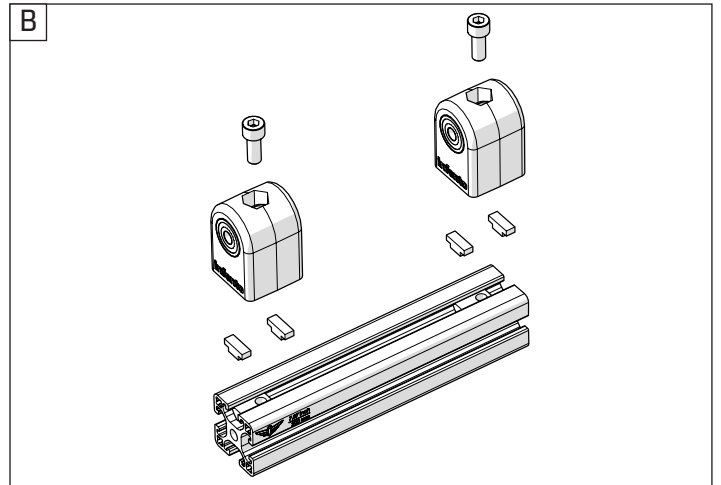
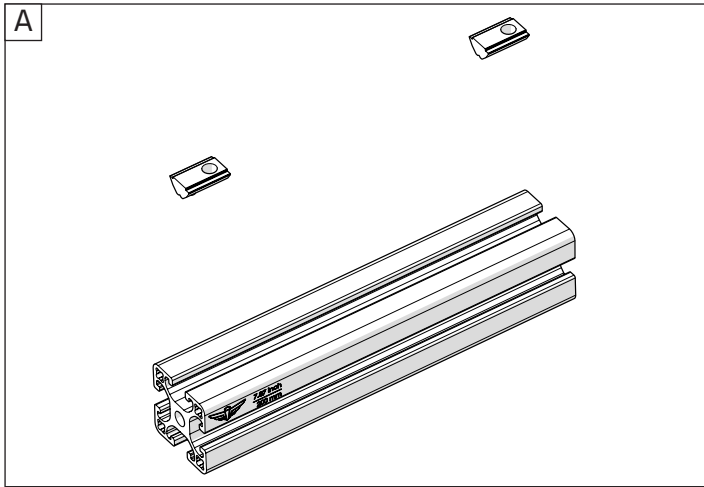
Profile 1x
7.87inch | 200mm





39

ride B-TRIKE

- Bolt M8x20 (low head) 2x
- T-Positioning block 6x
- Bolt M8x20 1x
- L-joint 1x
- Multi angle joint 1x

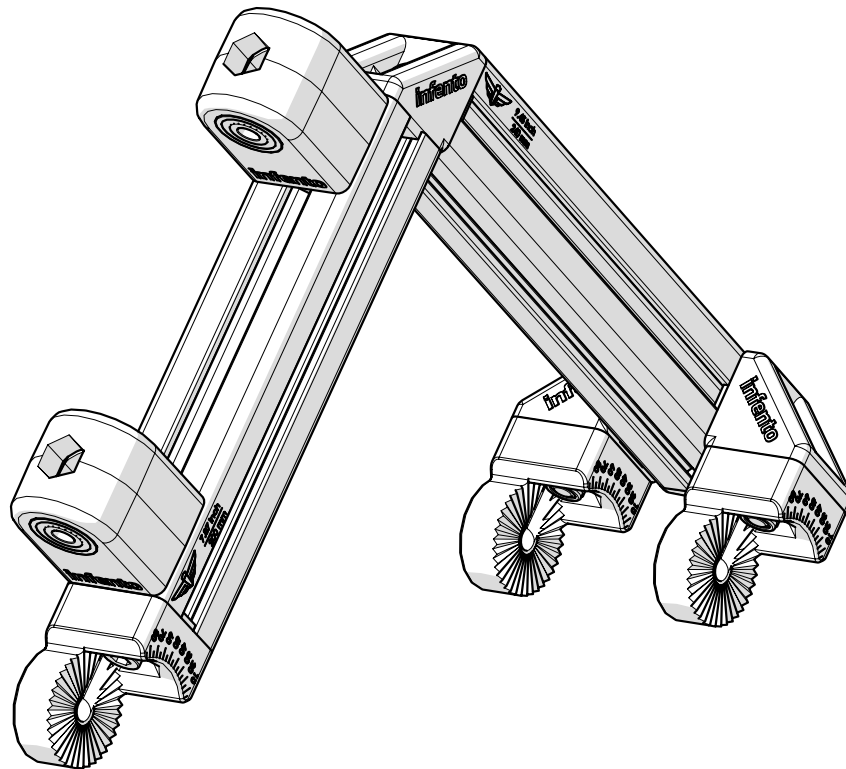
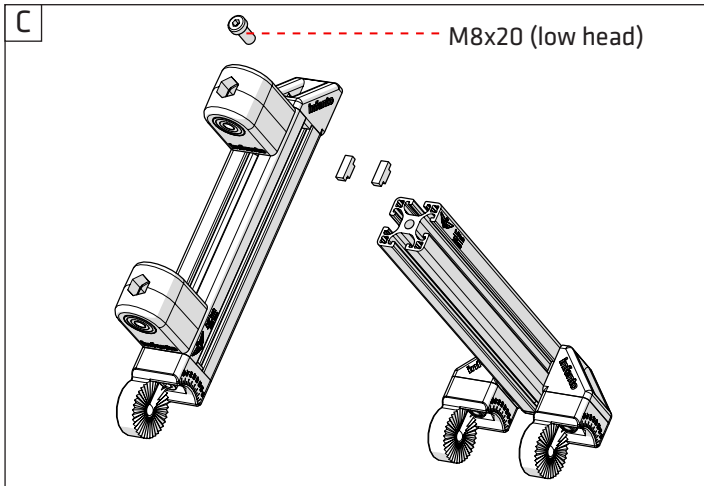
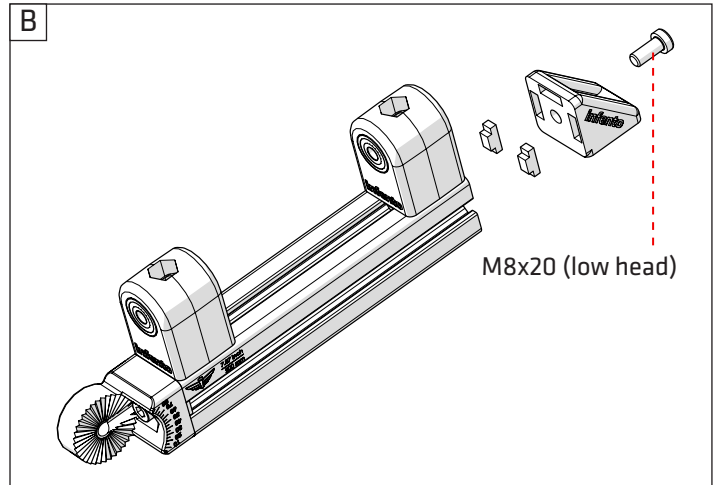
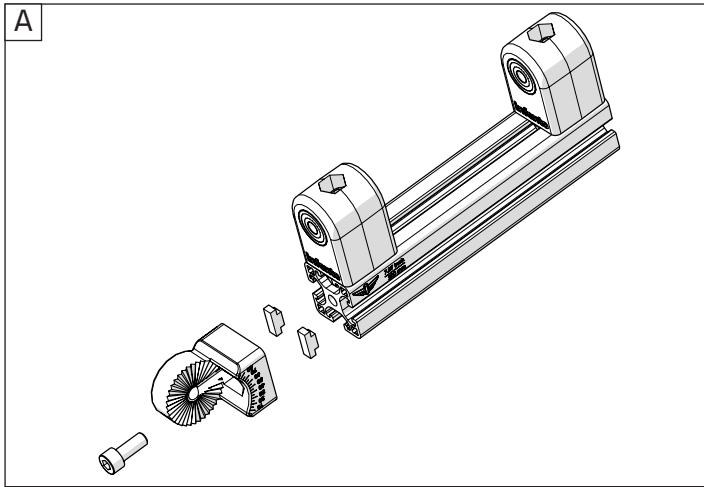



40

ride B-TRIKE

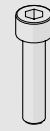

3x



3x

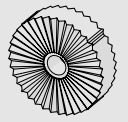

3x

Bolt M8x35

Locknut M8

Knurled disc 2 stripes

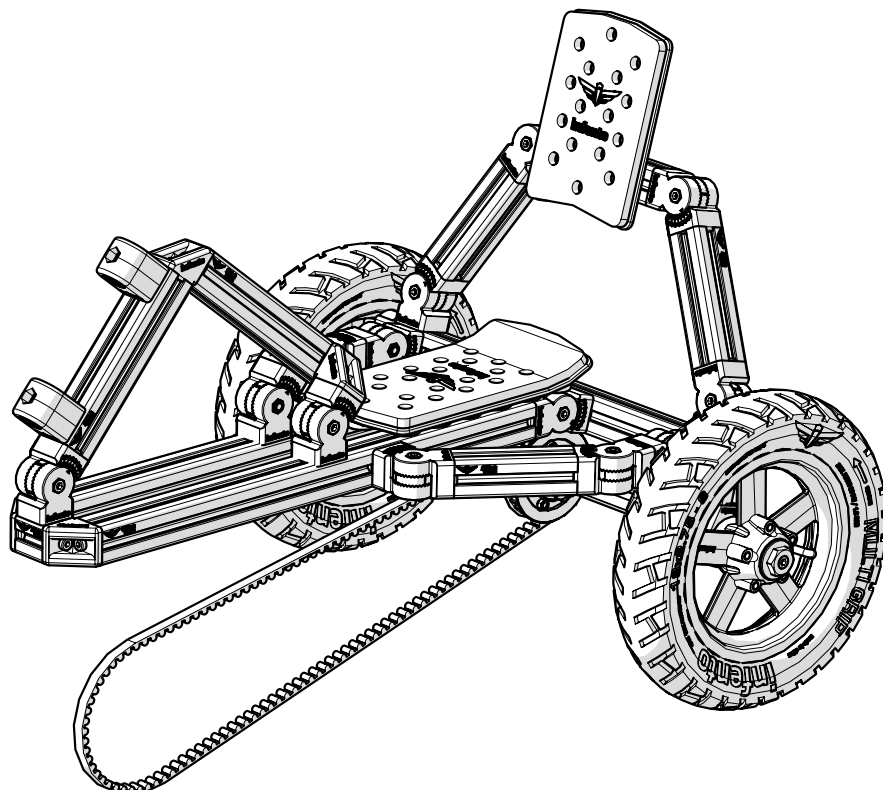
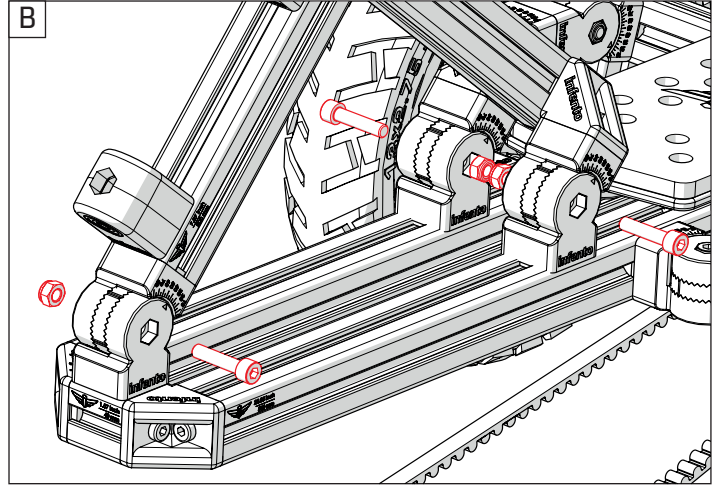
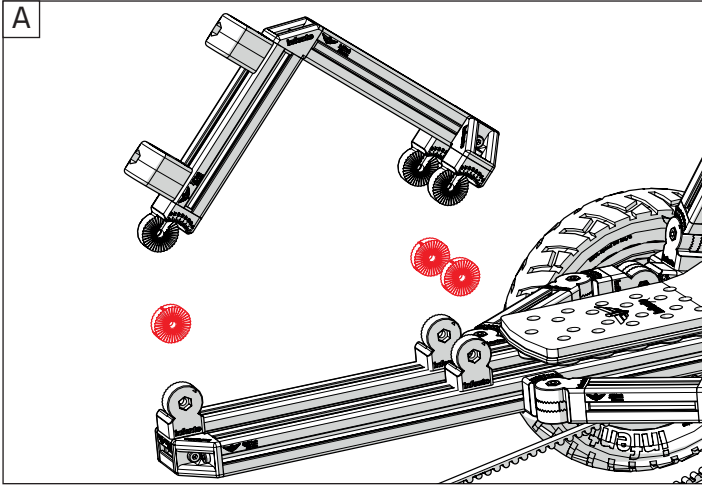



41

ride **B-TRIKE**

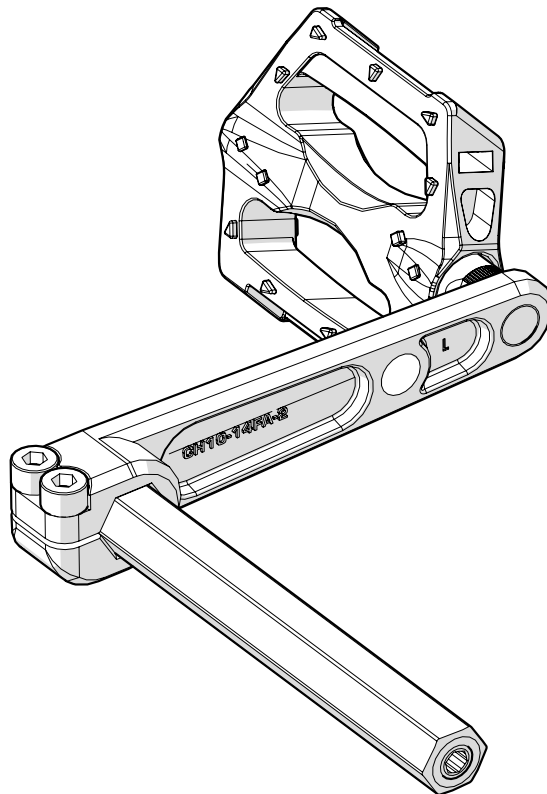
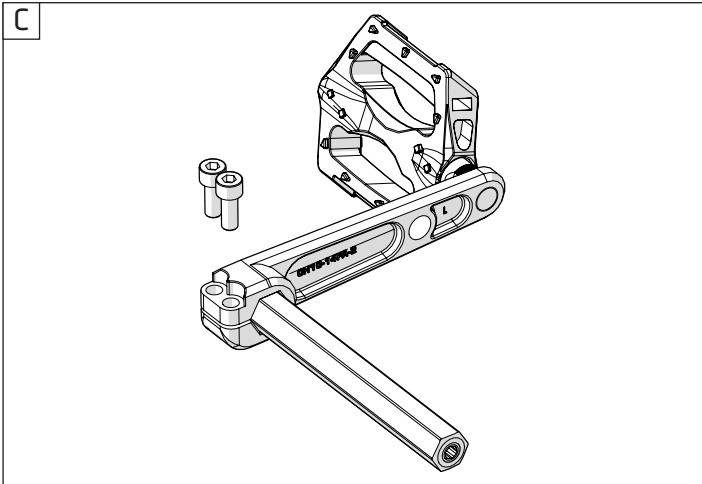
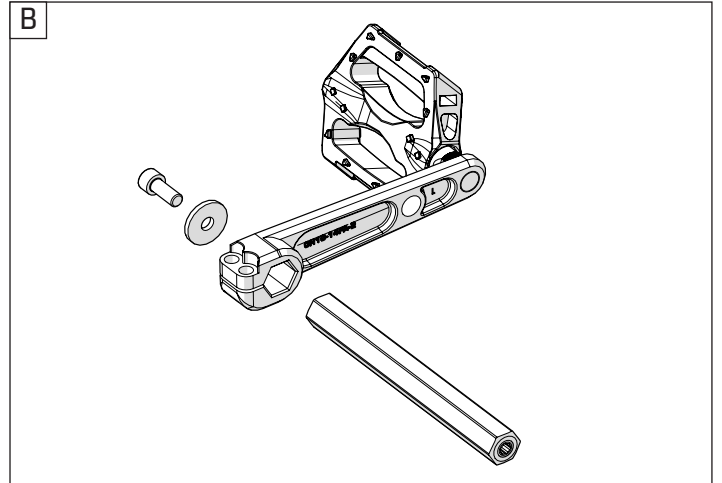
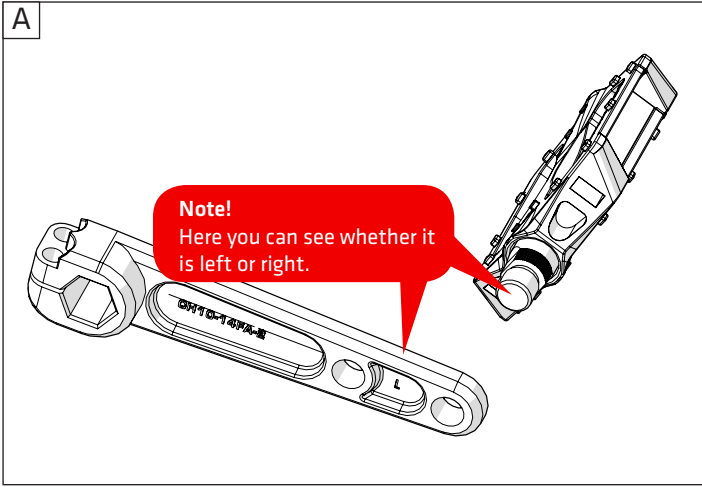
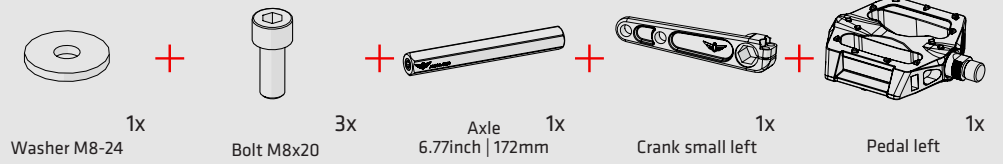



42

ride B-TRIKE

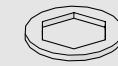

Spacer 3x
0.08inch | 2 mm

+

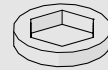

Spacer 1x
0.2inch | 5 mm

+

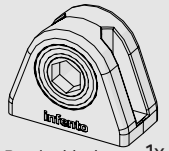



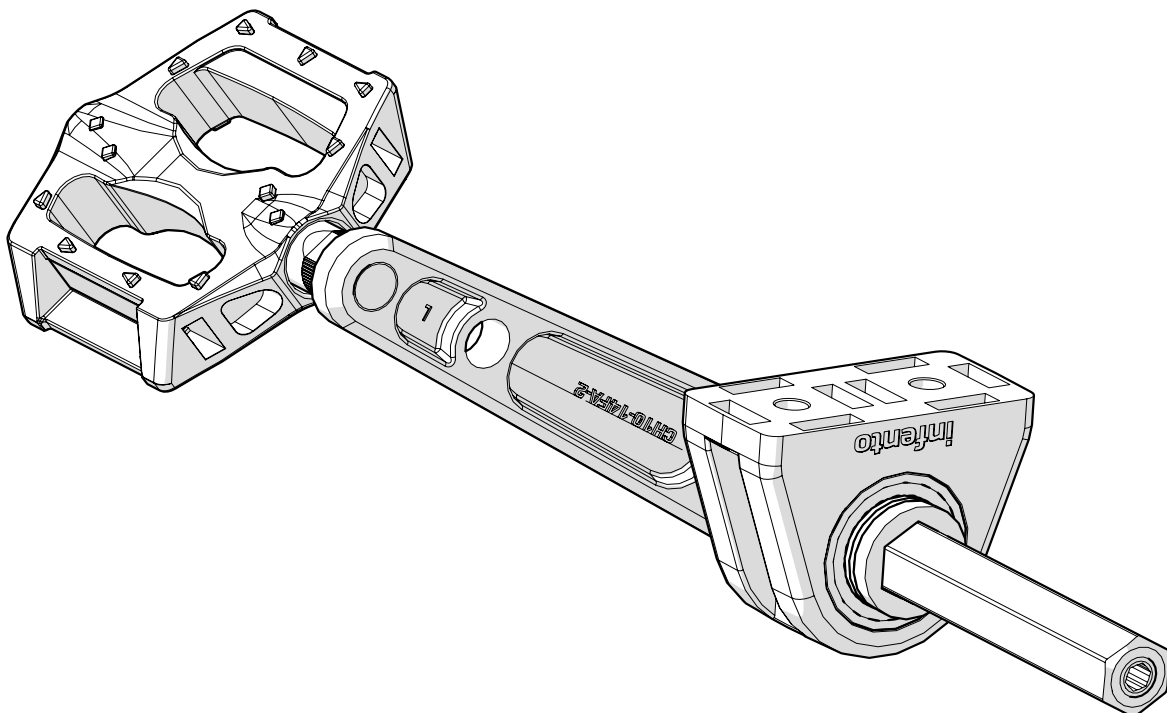
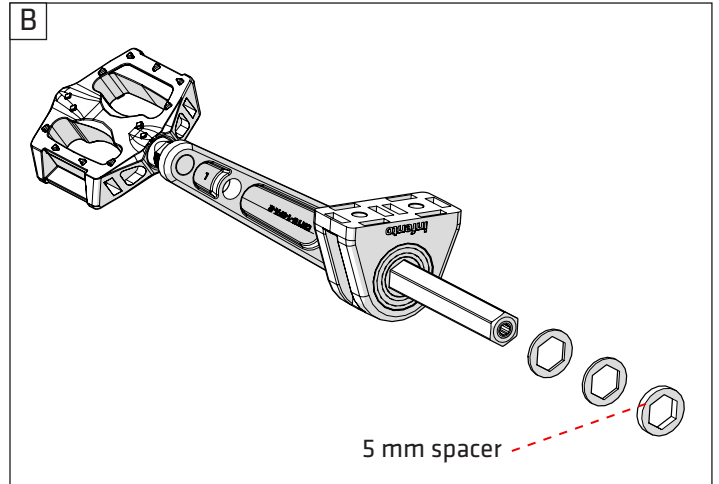
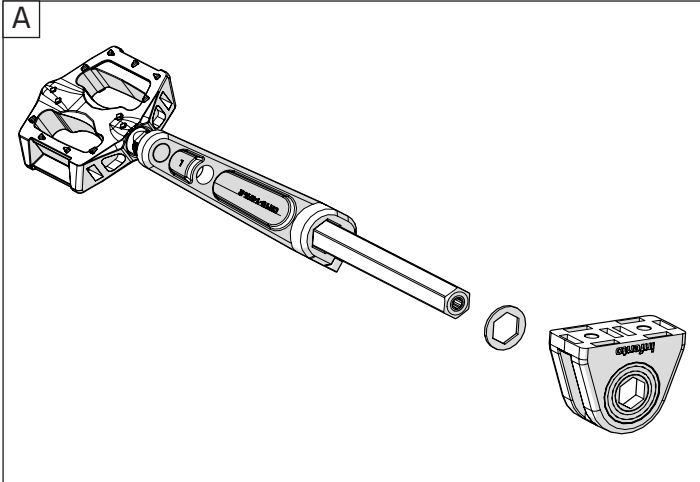

Bearingblock 1x
40x80_hexa 19



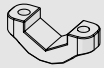

43

ride B-TRIKE

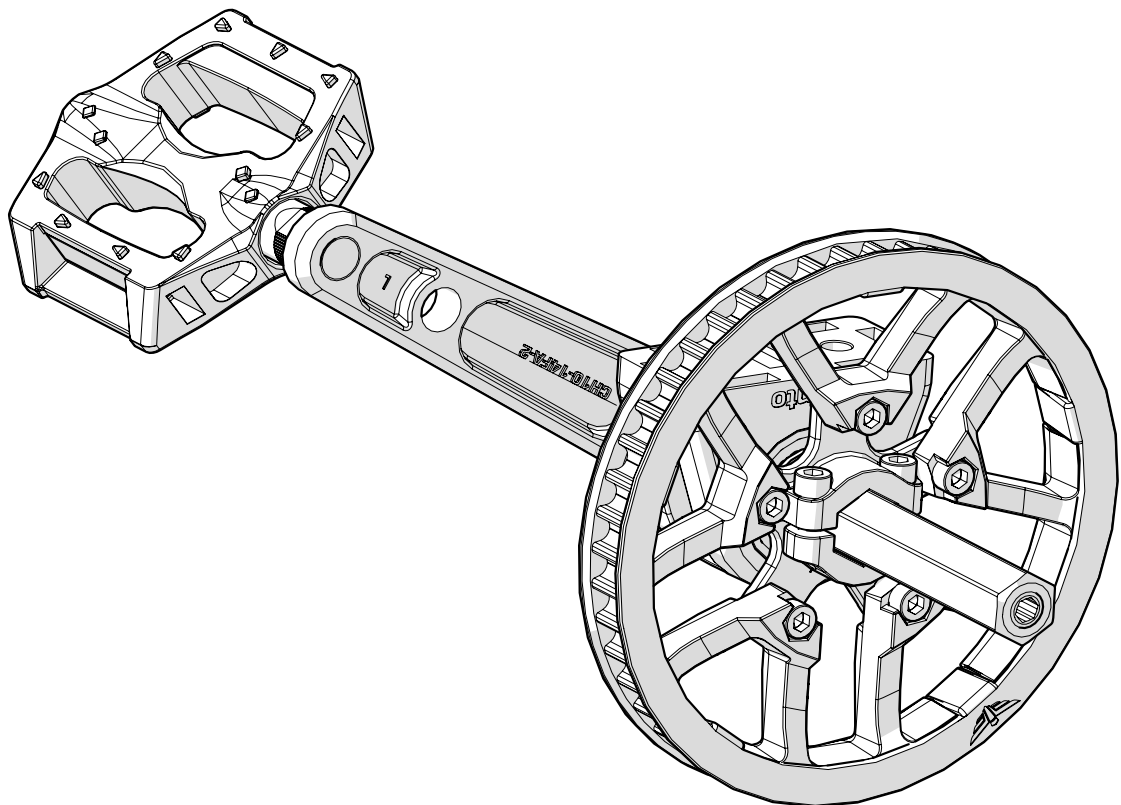
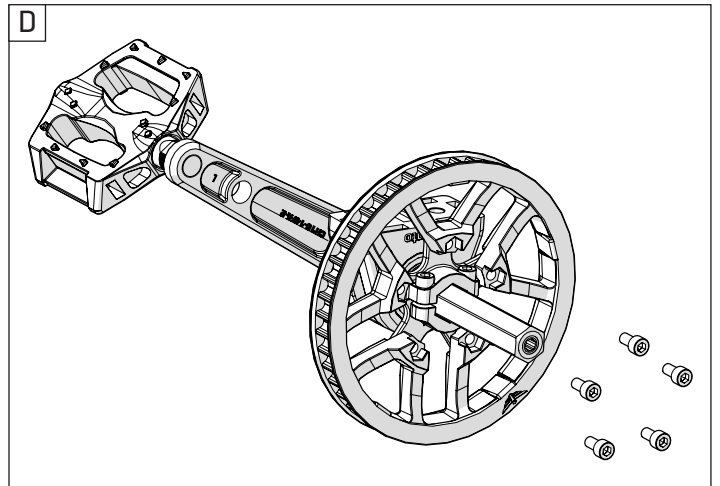
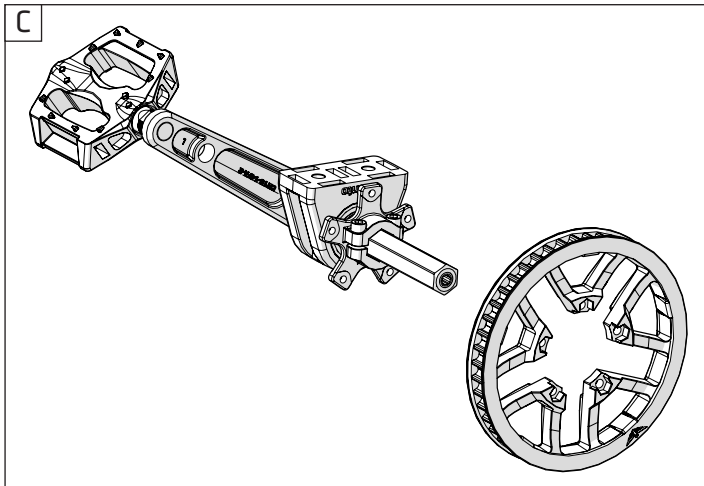
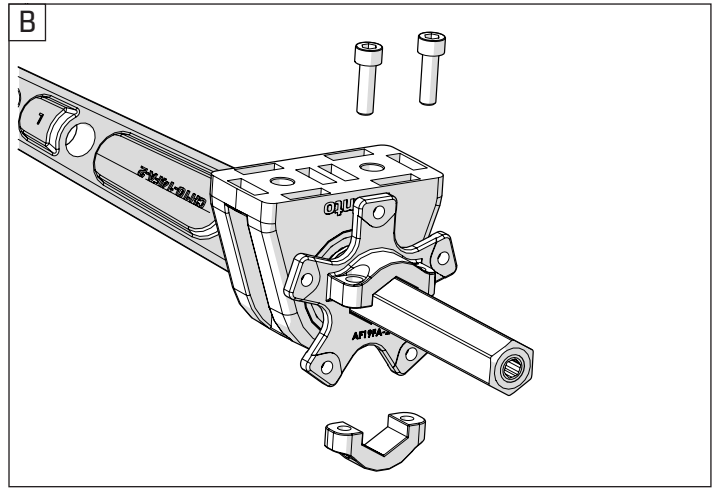
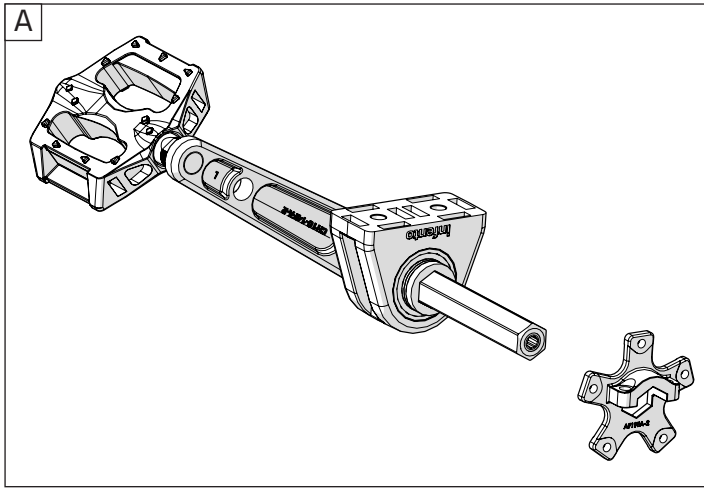

-  5x Bolt M6x12
-  1x Toothed belt pulley 46T
-  2x Bolt M6x20
-  1x Clamping part holes with M6 thread
-  1x Axle flange



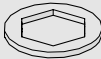

44

ride **B-TRIKE**

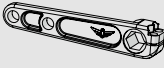
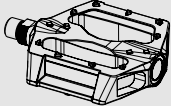

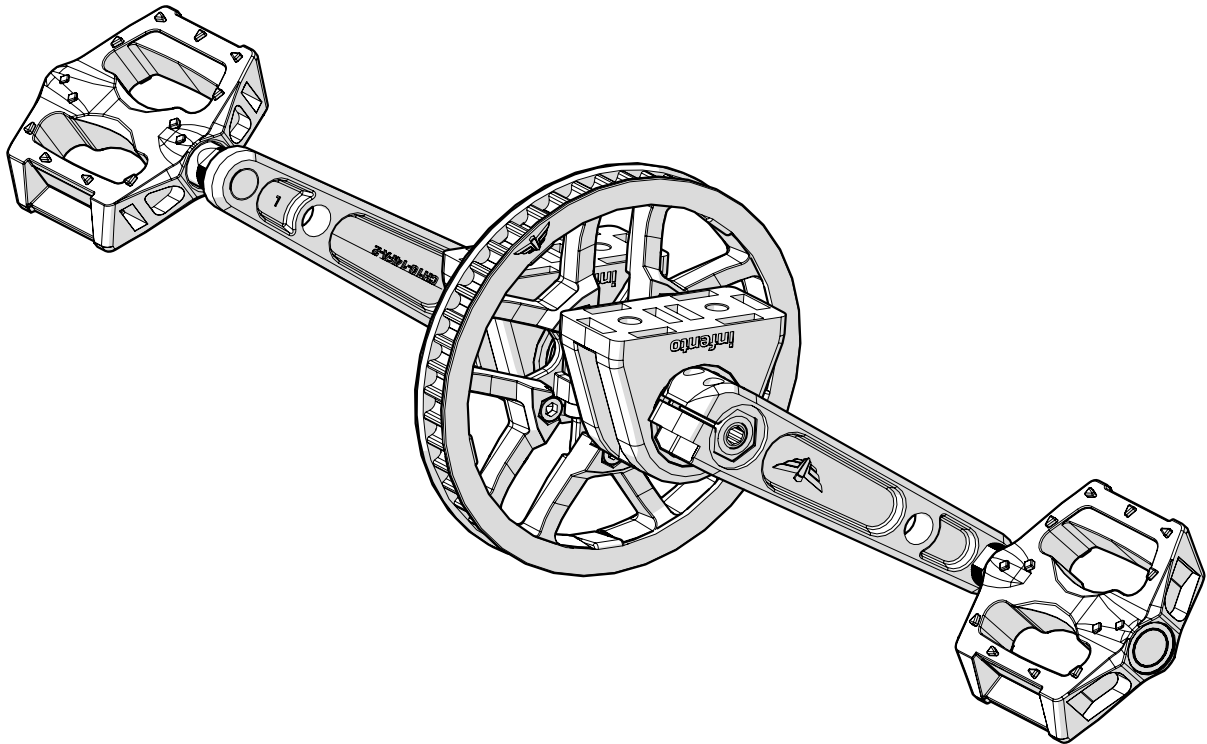
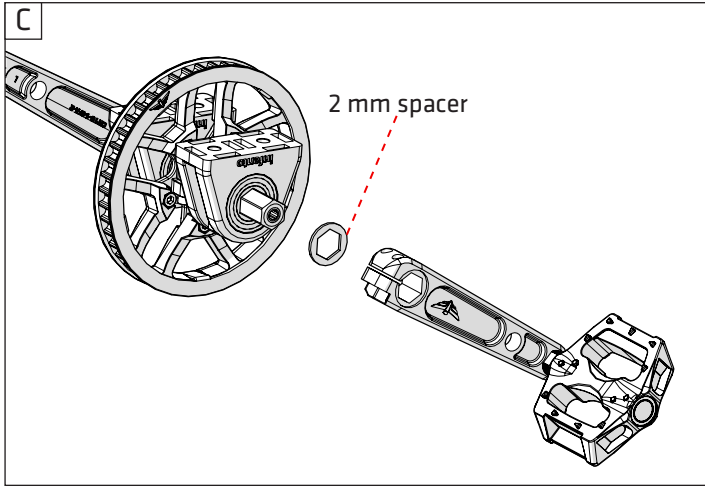
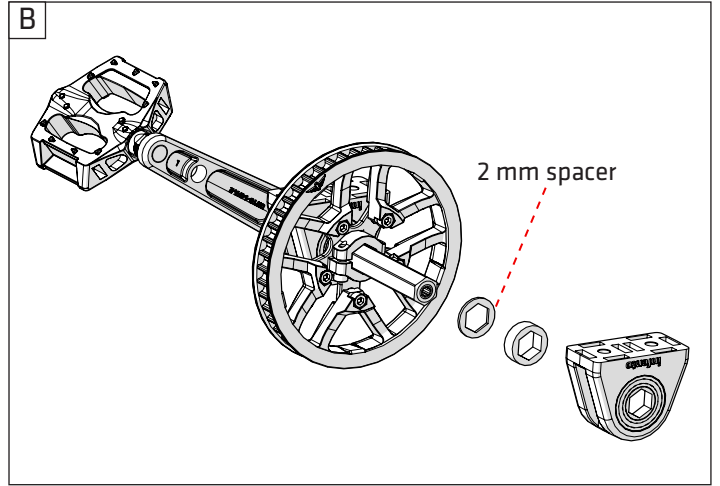
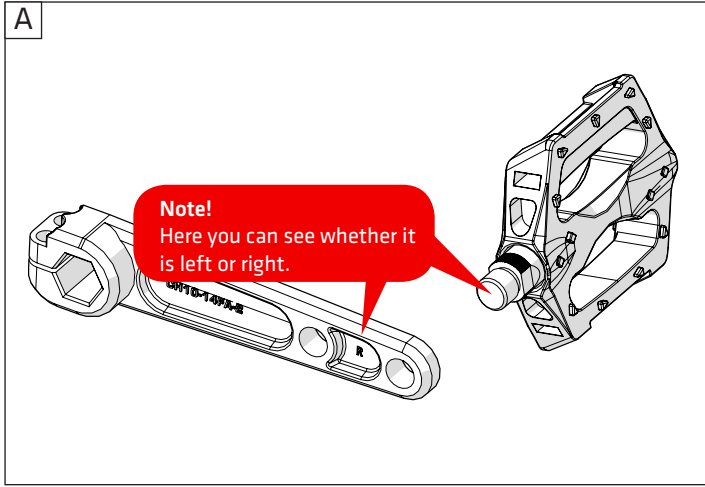
- 
Spacer 2x
0.08inch | 2 mm
- +
- 
Spacer 1x
0.39inch | 10mm
- +
- 
Bearingblock 1x
40x80_hexa 19
- +
- 
Crank small right 1x
- +
- 
Pedal right 1x





45

ride B-TRIKE

- 
Washer M8-24
- +
- 
Bolt M8x20
- +
- 
T-Positioning block
- 4x

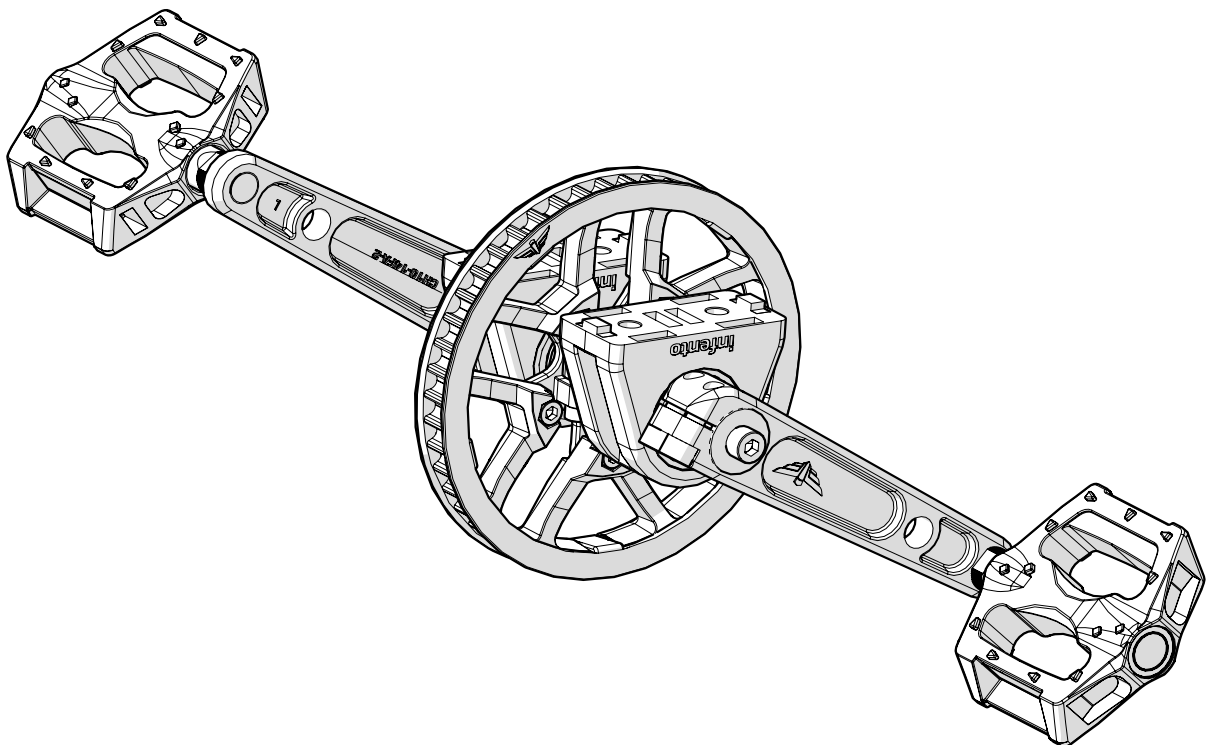
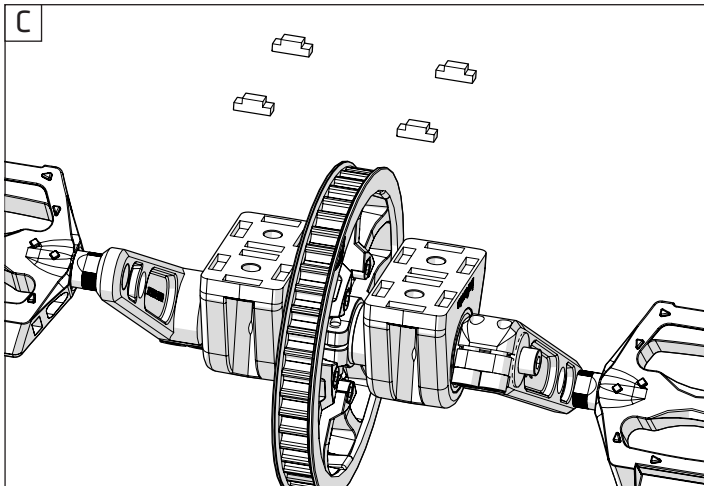
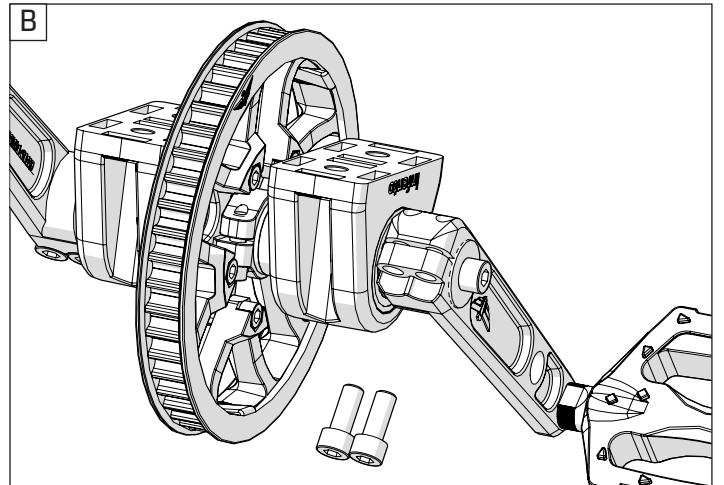
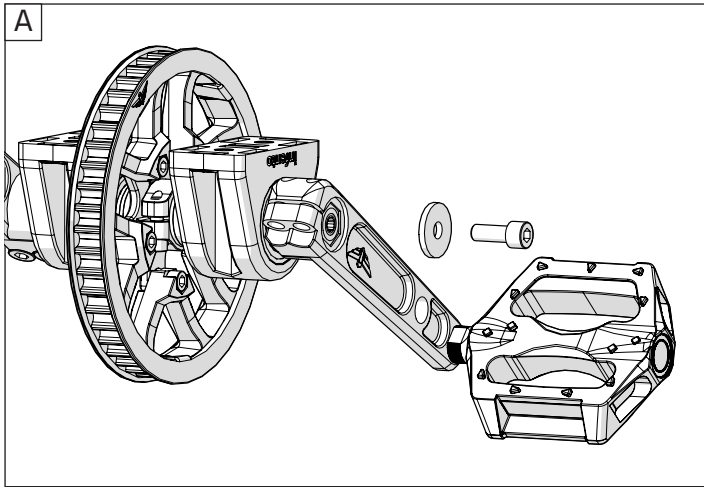



46

ride B-TRIKE



+



4x

4x

Profile nut short

Bolt M8x20

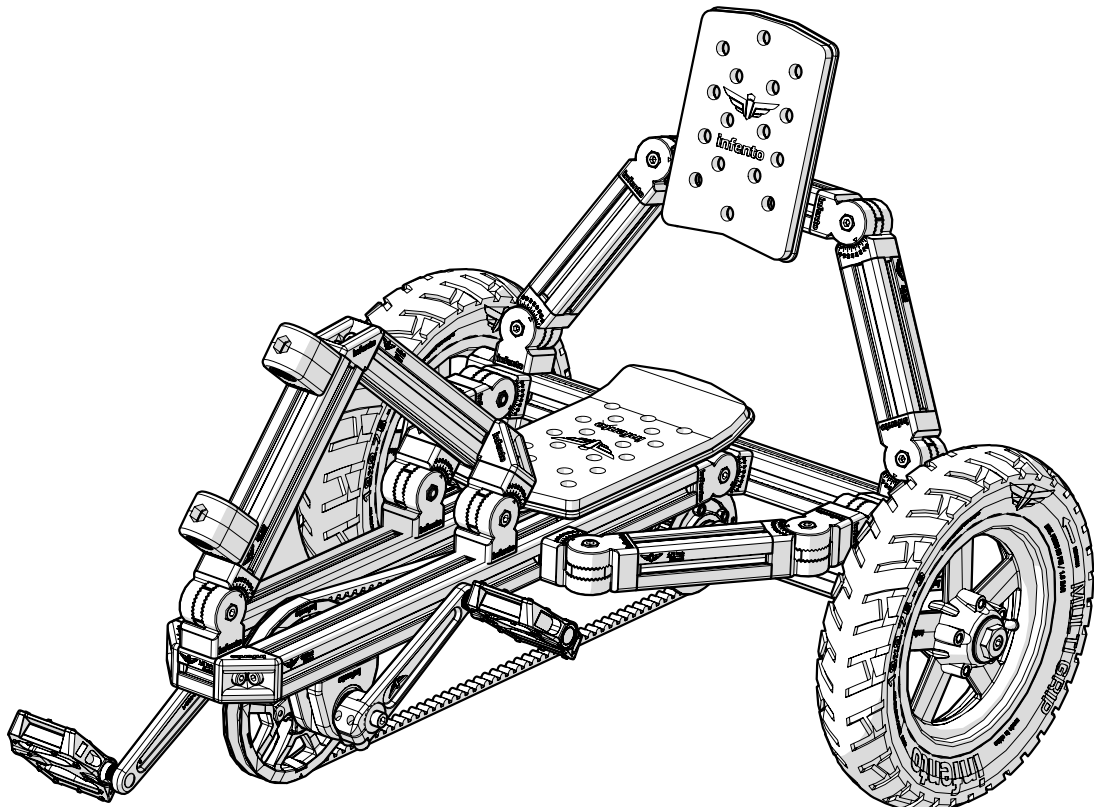
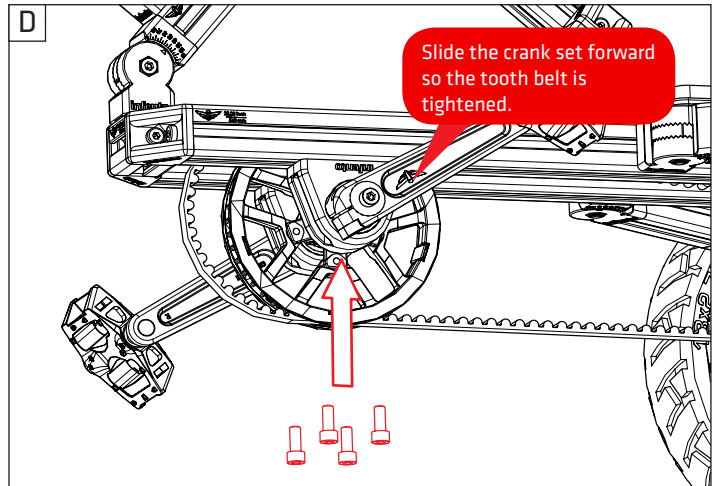
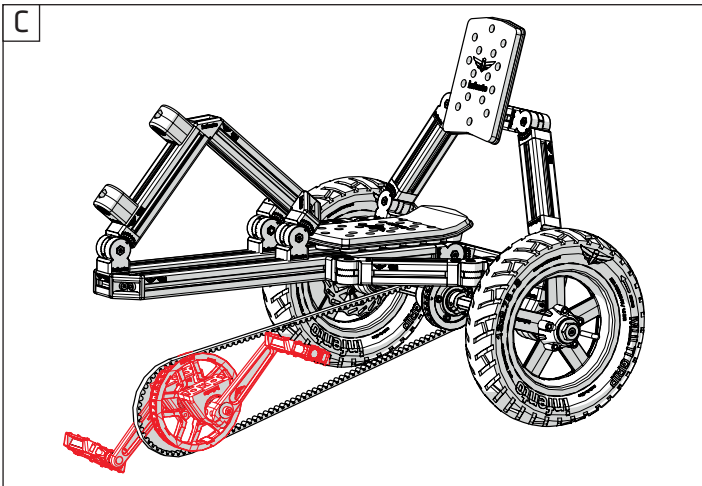
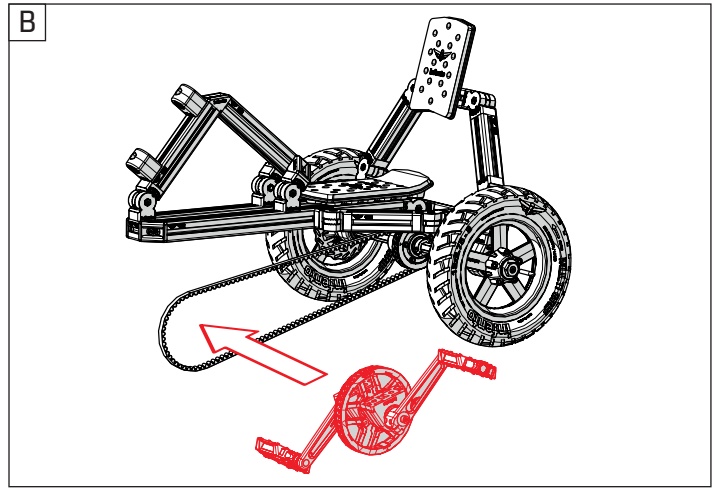
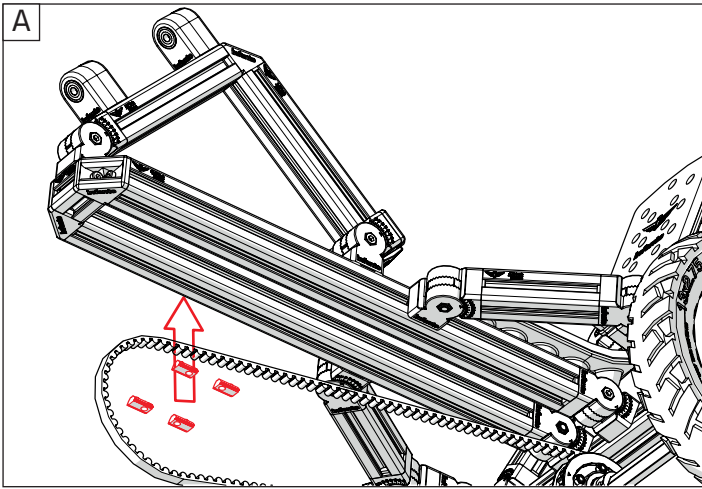



47

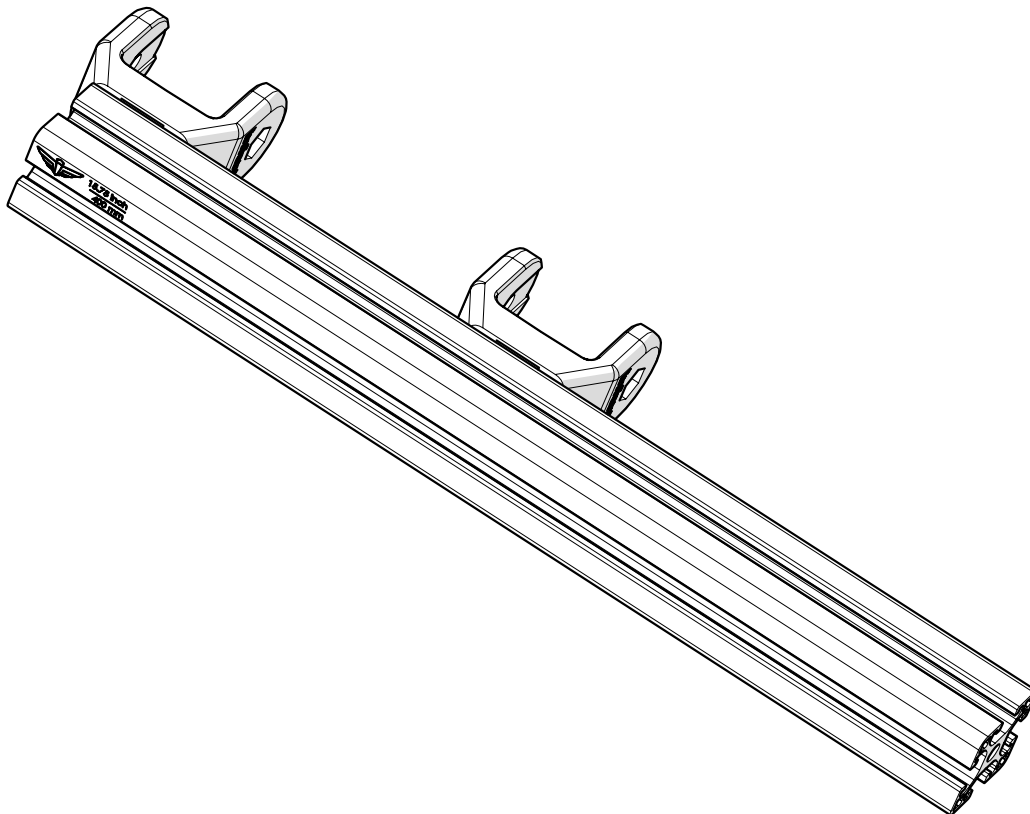
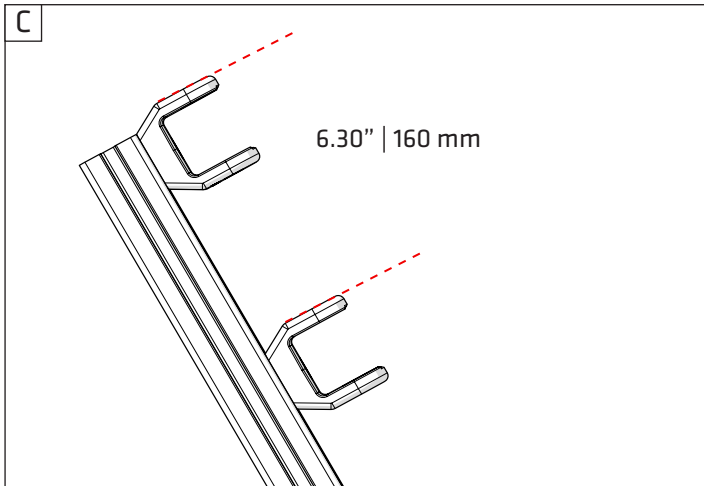
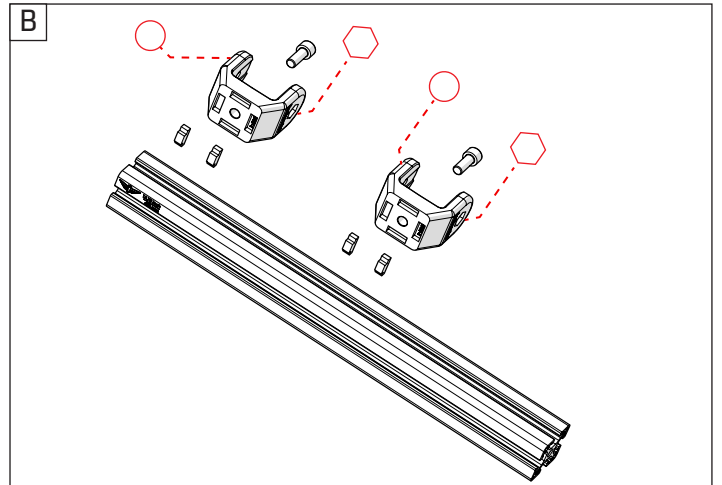
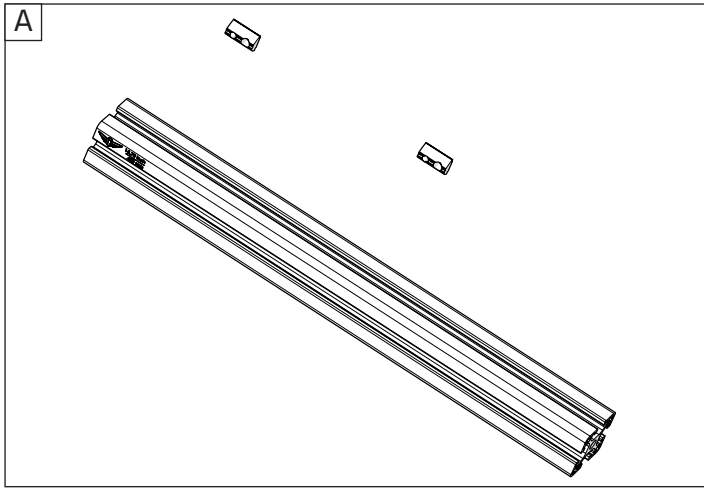
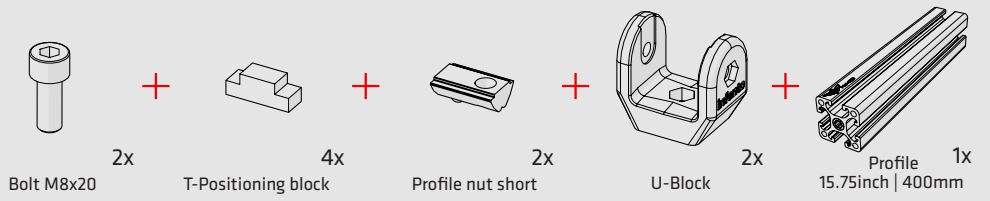

ride **B-TRIKE**





48

ride *B-TRIKE*

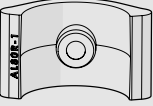
- 
Locknut M8 2x
- 
Bolt M8x60 2x
- 
Washer M8-16 4x
- 
Angle limiter 40° 2x

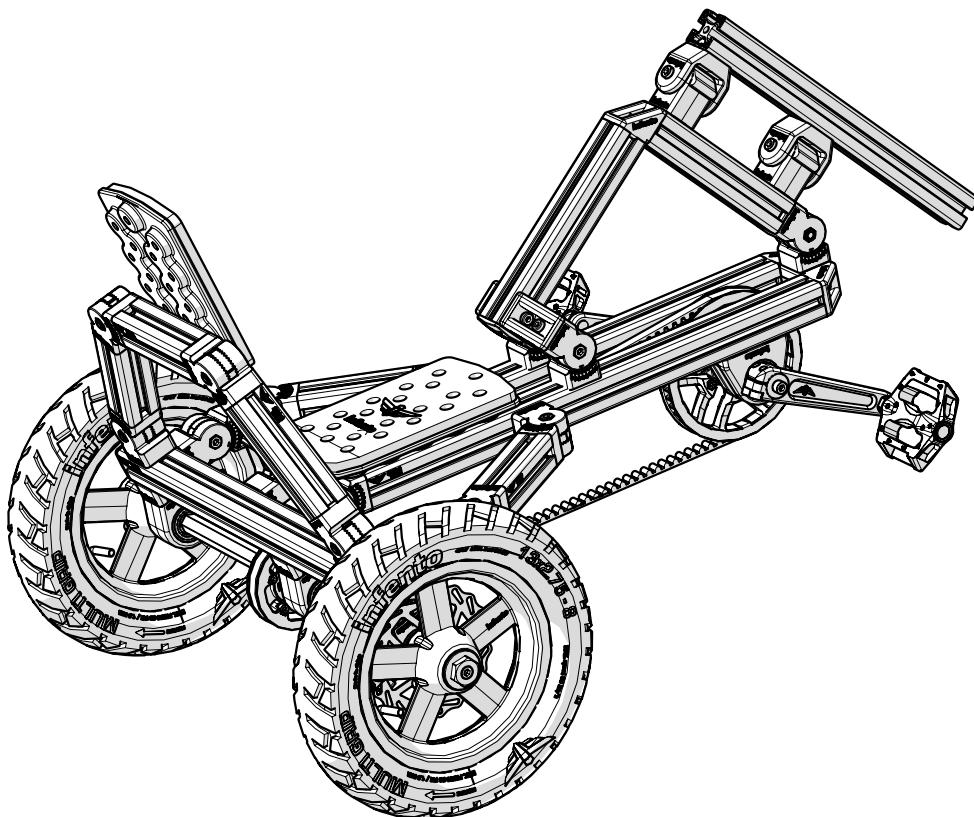
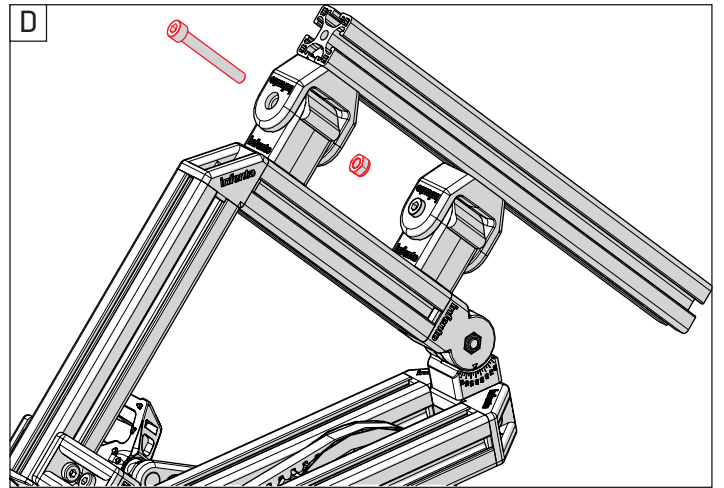
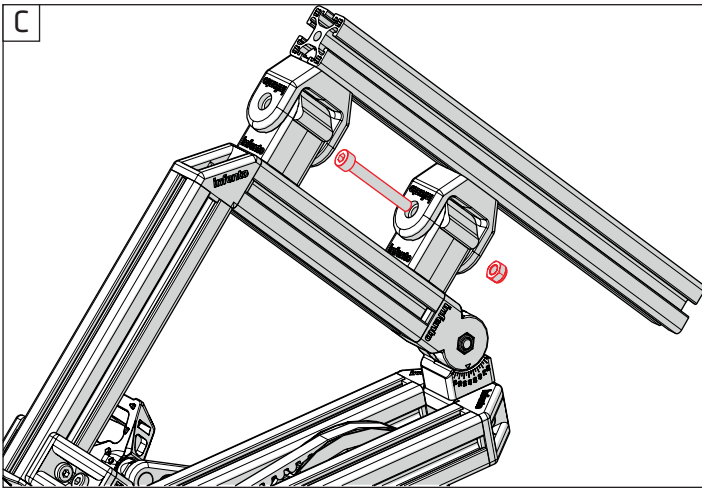
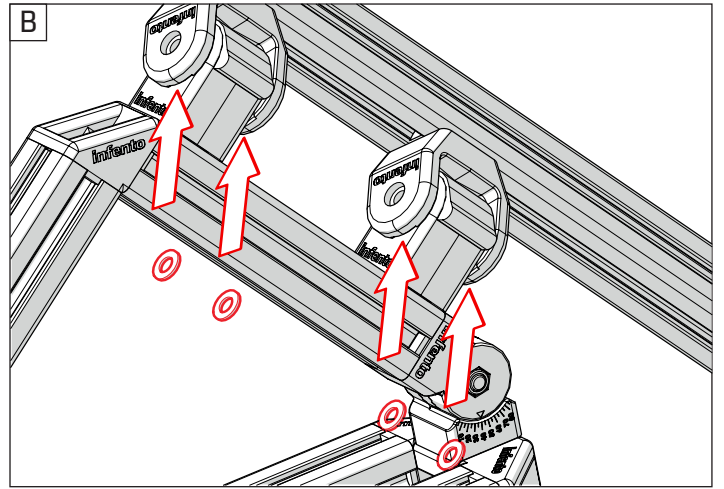
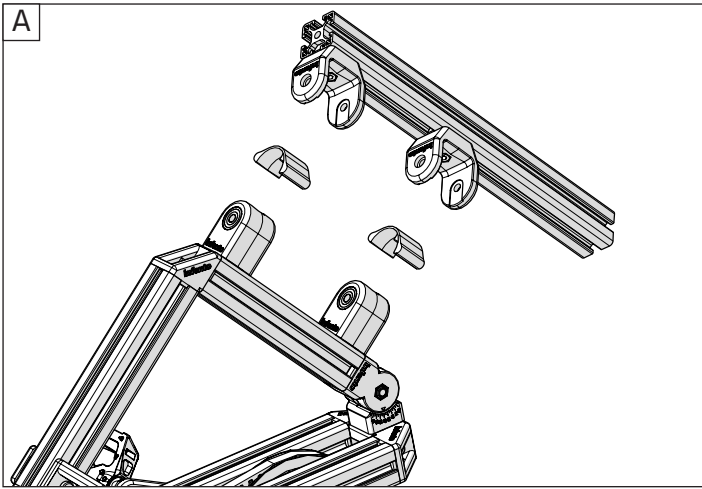



49

ride B-TRIKE



Bolt M8x20
(low head) 2x

+



T-Positioning block 4x

+

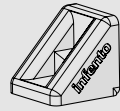

L-joint 2x

+

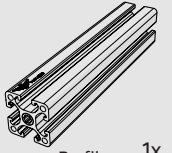

Profile 1x
7.87inch | 200mm

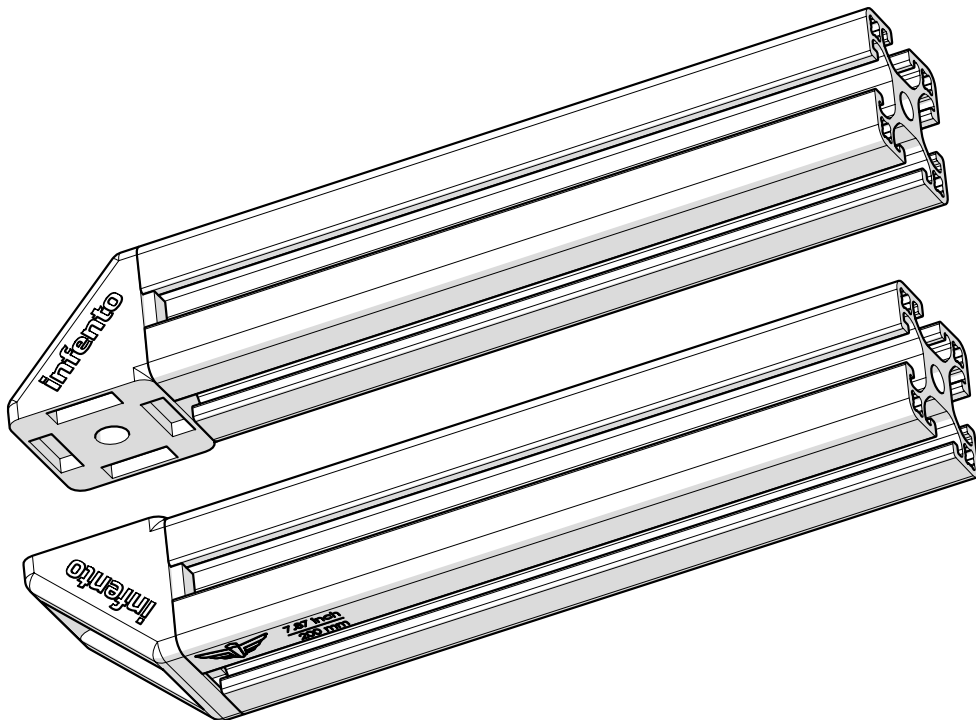
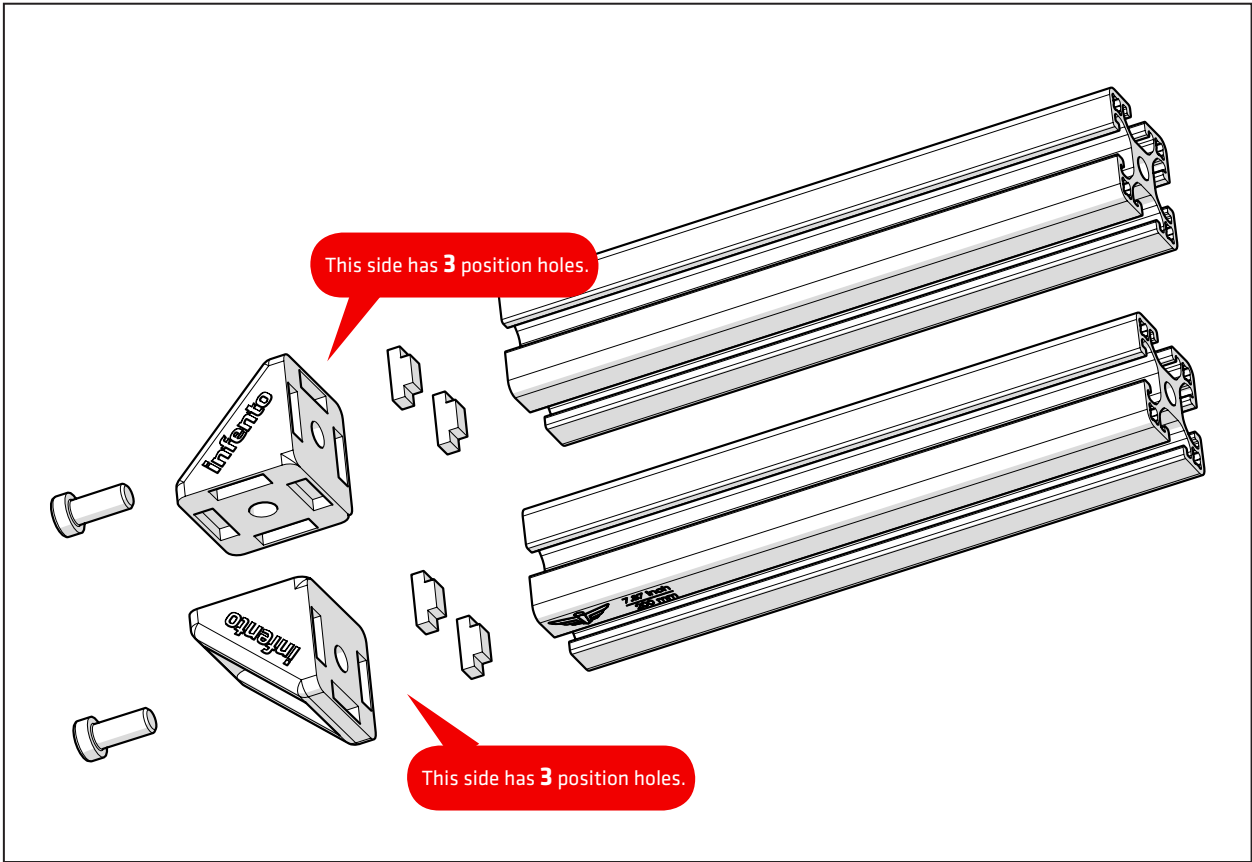



50

ride **B-TRIKE**



+



+



4x
T-Positioning block

2x
Profile nut short

2x
Bolt M8x20
(low head)

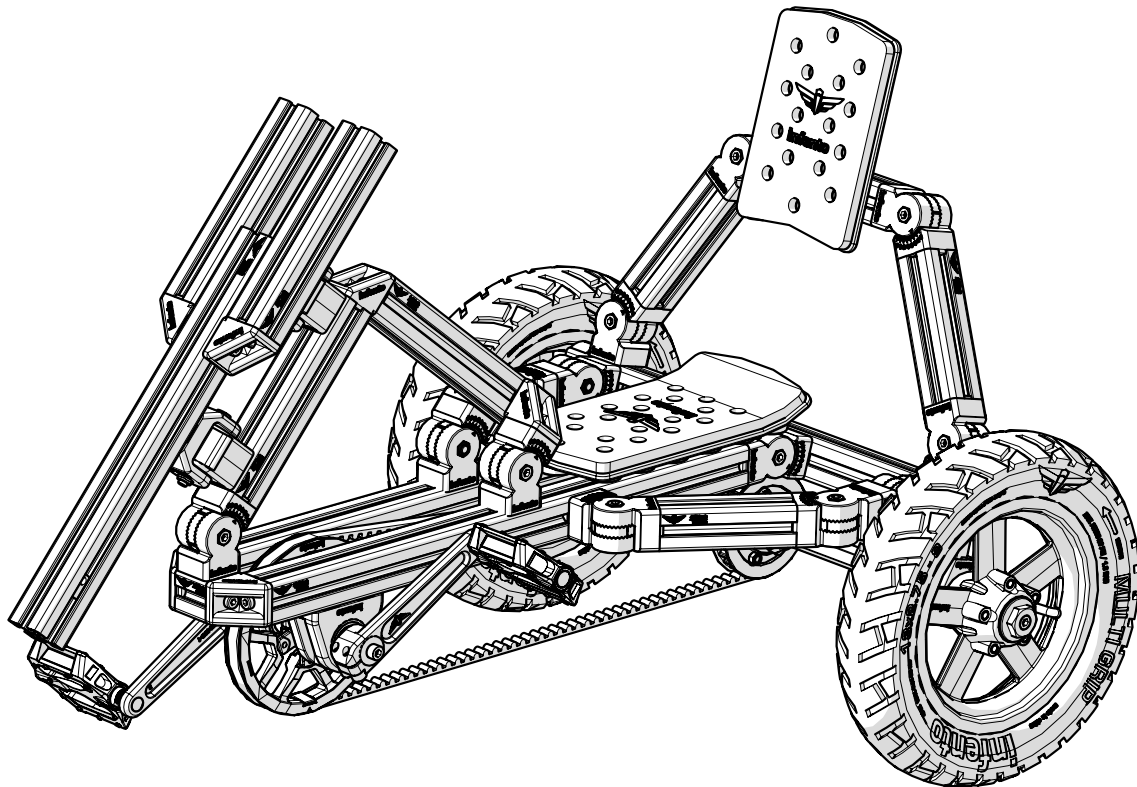
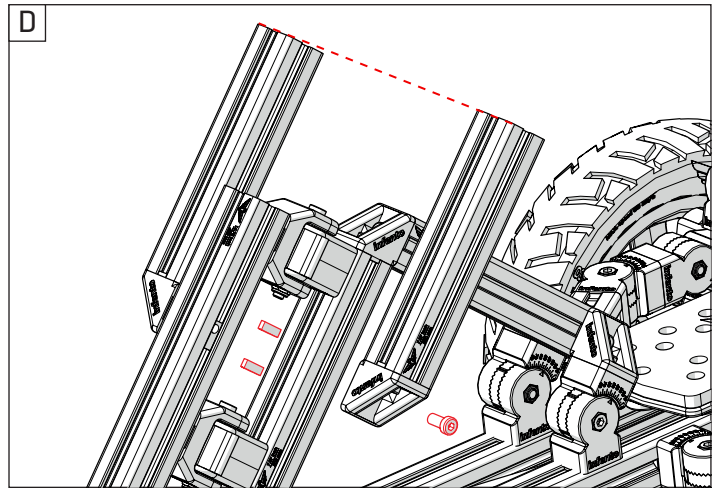
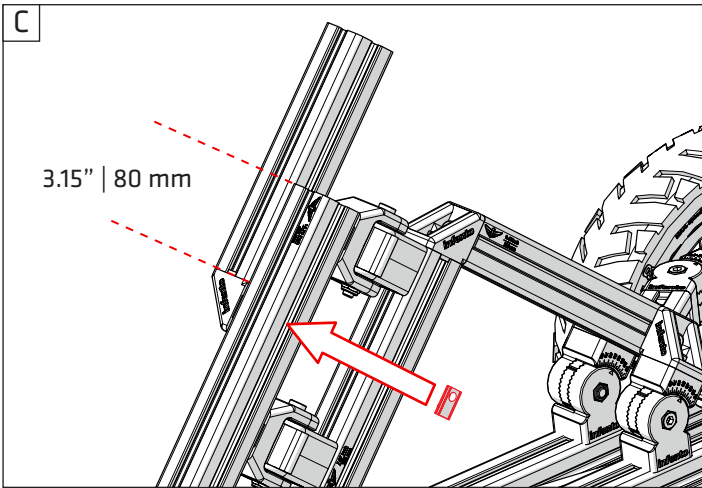
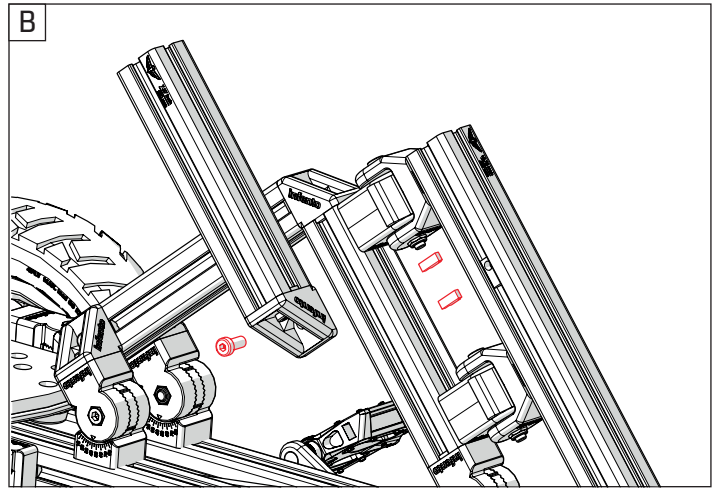
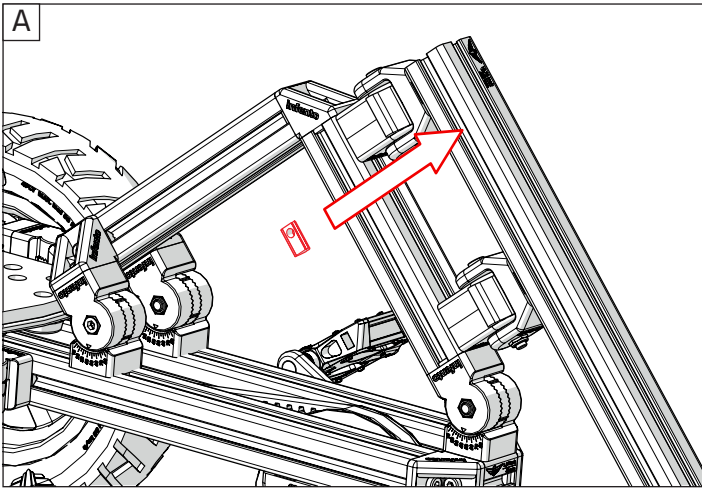



51

ride B-TRIKE

- Bolt M8x20 (low head) 2x
- T-Positioning block 4x
- L-joint 2x
- Protect cap 1x
- Parallel clamp joint 2x

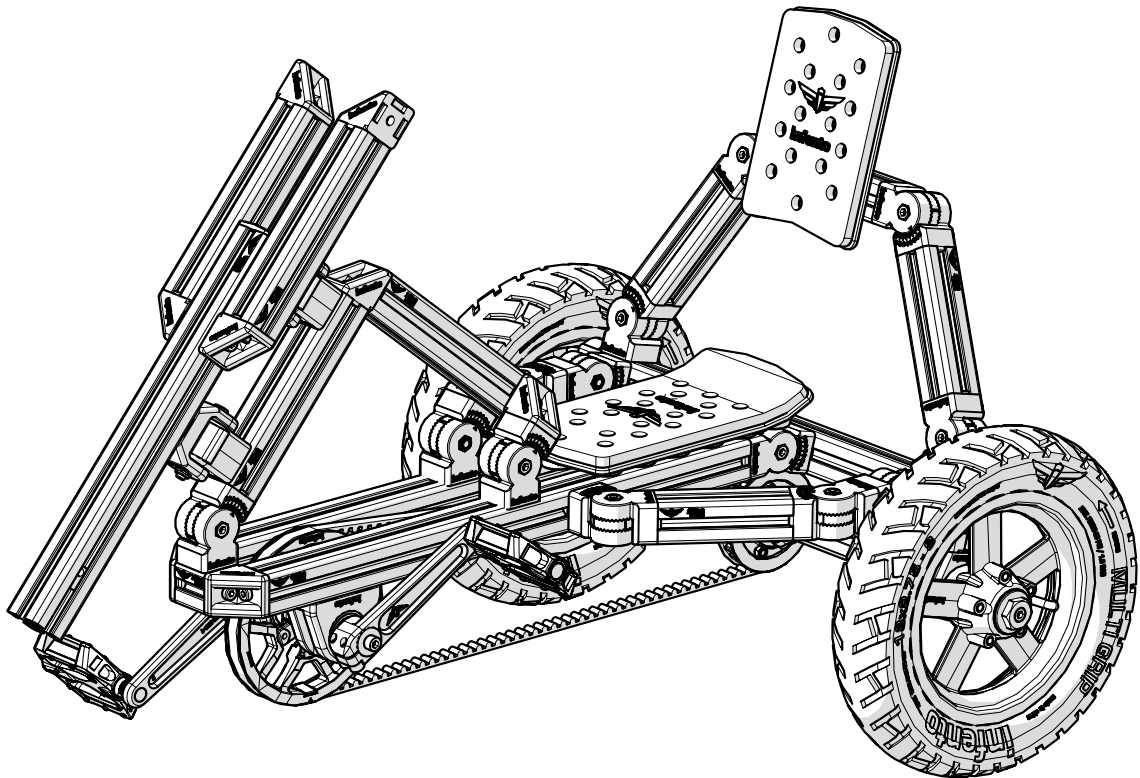
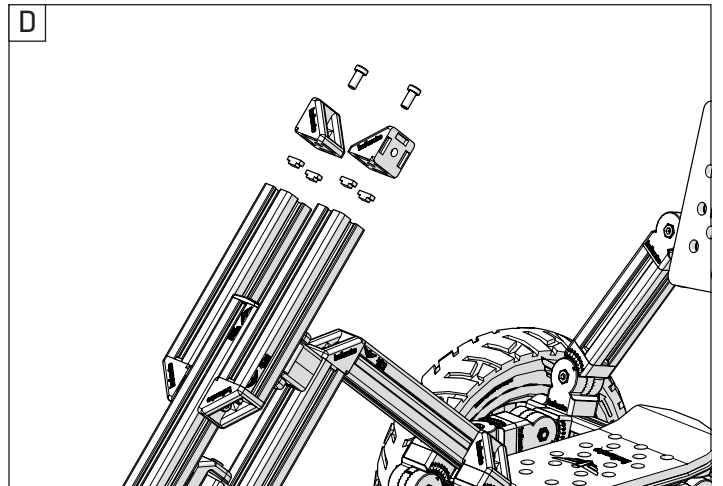
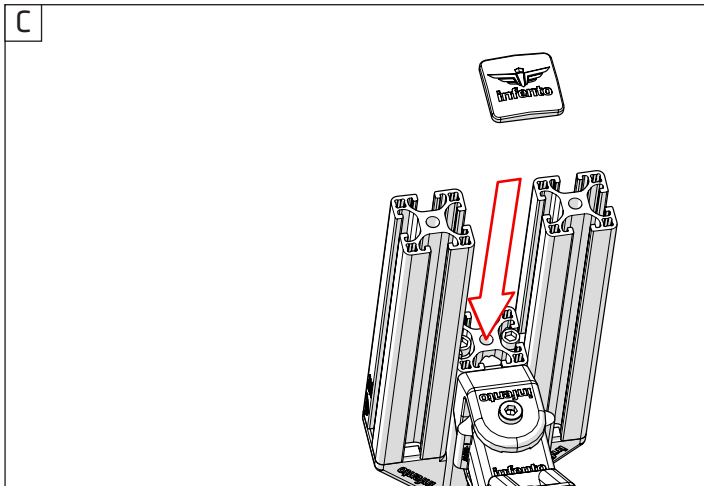
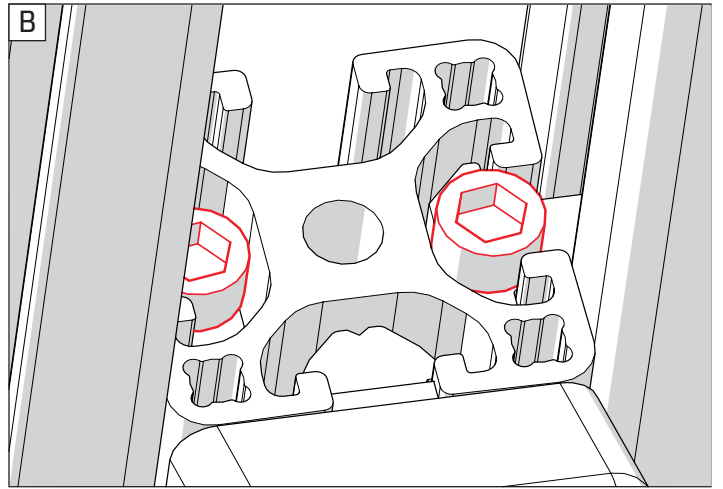
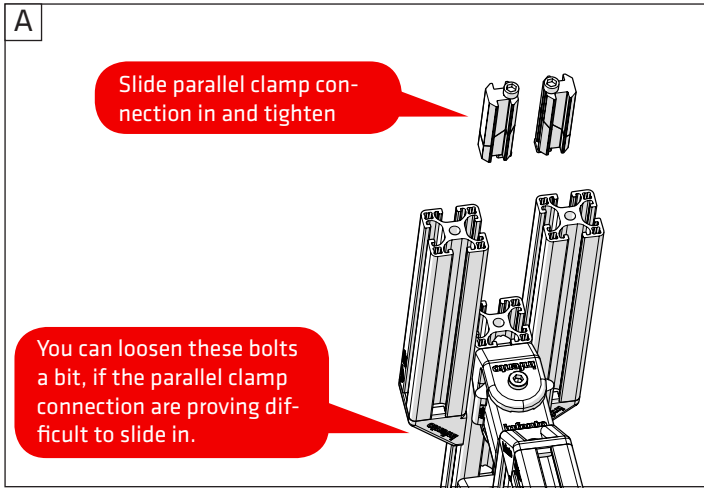



52

ride B-TRIKE

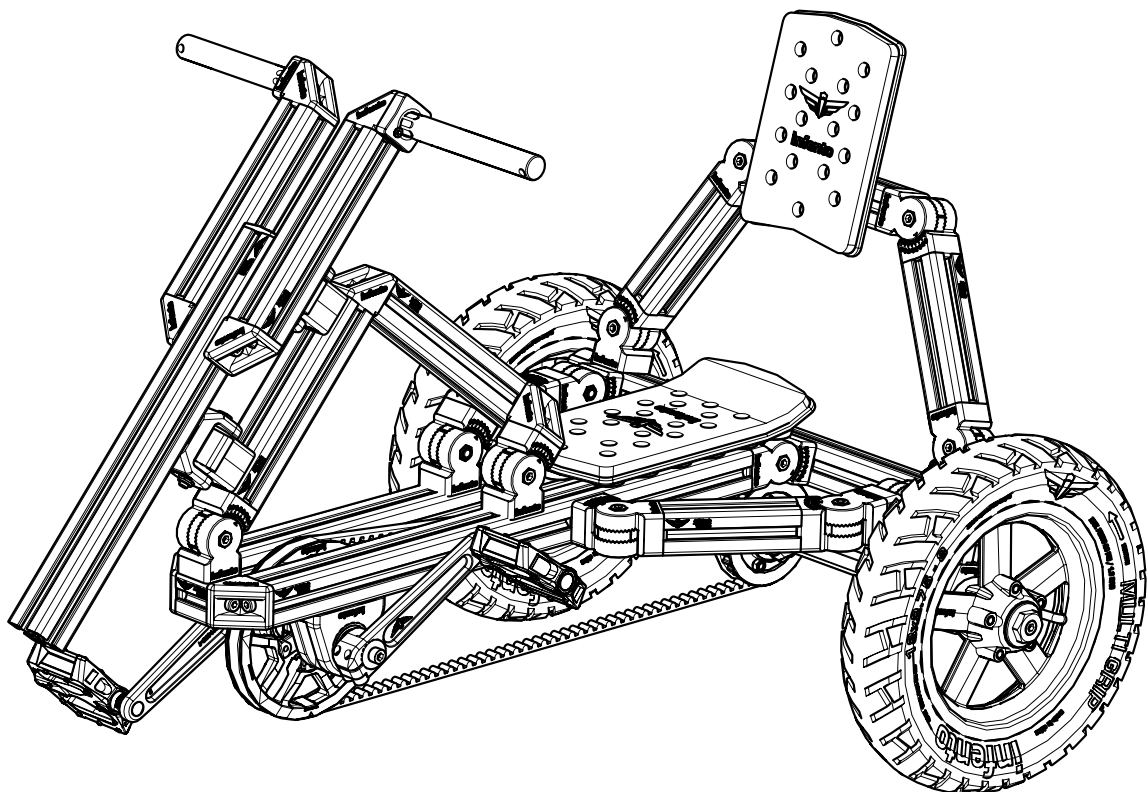
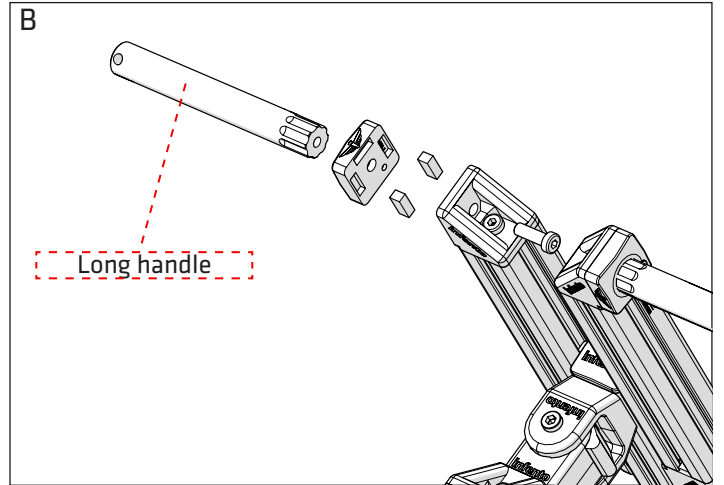
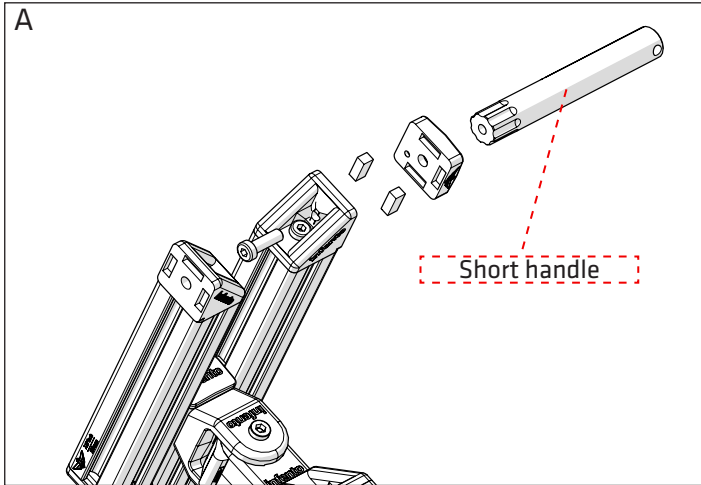



53

ride **B-TRIKE**

Bolt M8x20
(low head) 1x

+

T-Positioning block 4x

+

Bolt M8x20 1x

+

Multi angle joint 1x

+

L-joint 1x

+

Profile 1x
12.60inch | 320mm

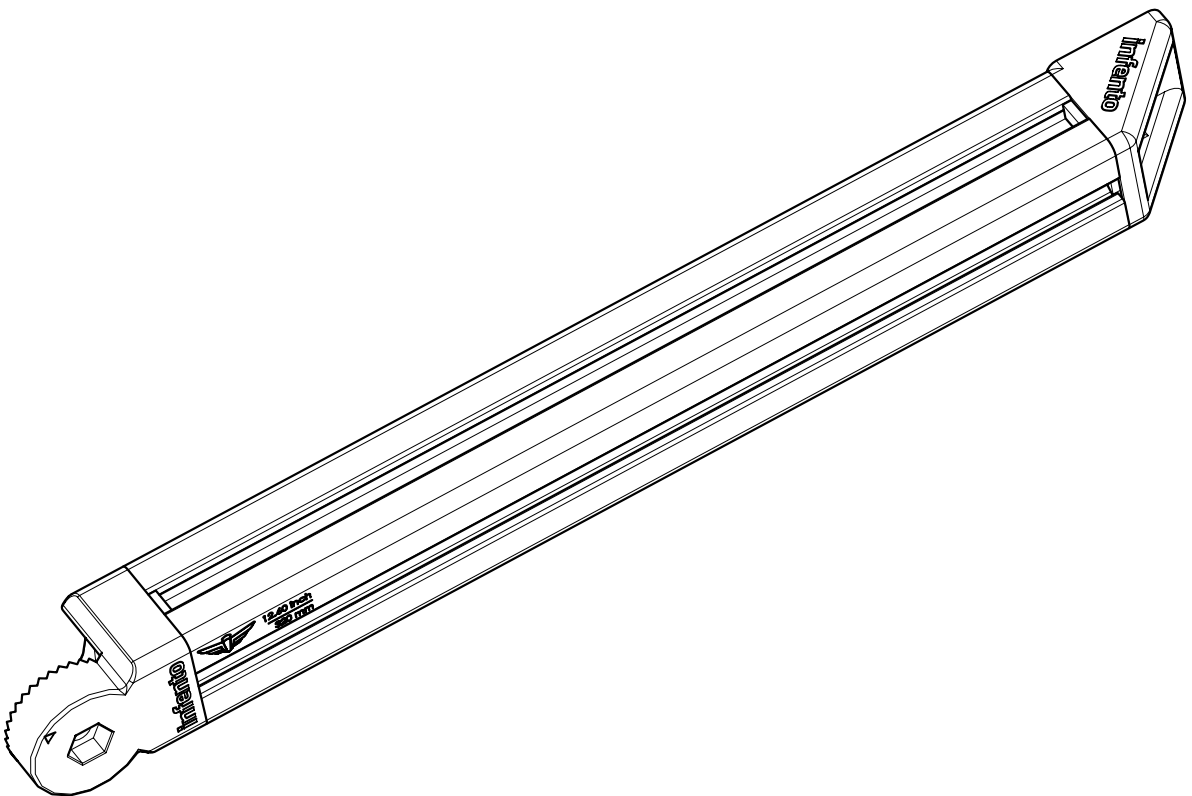
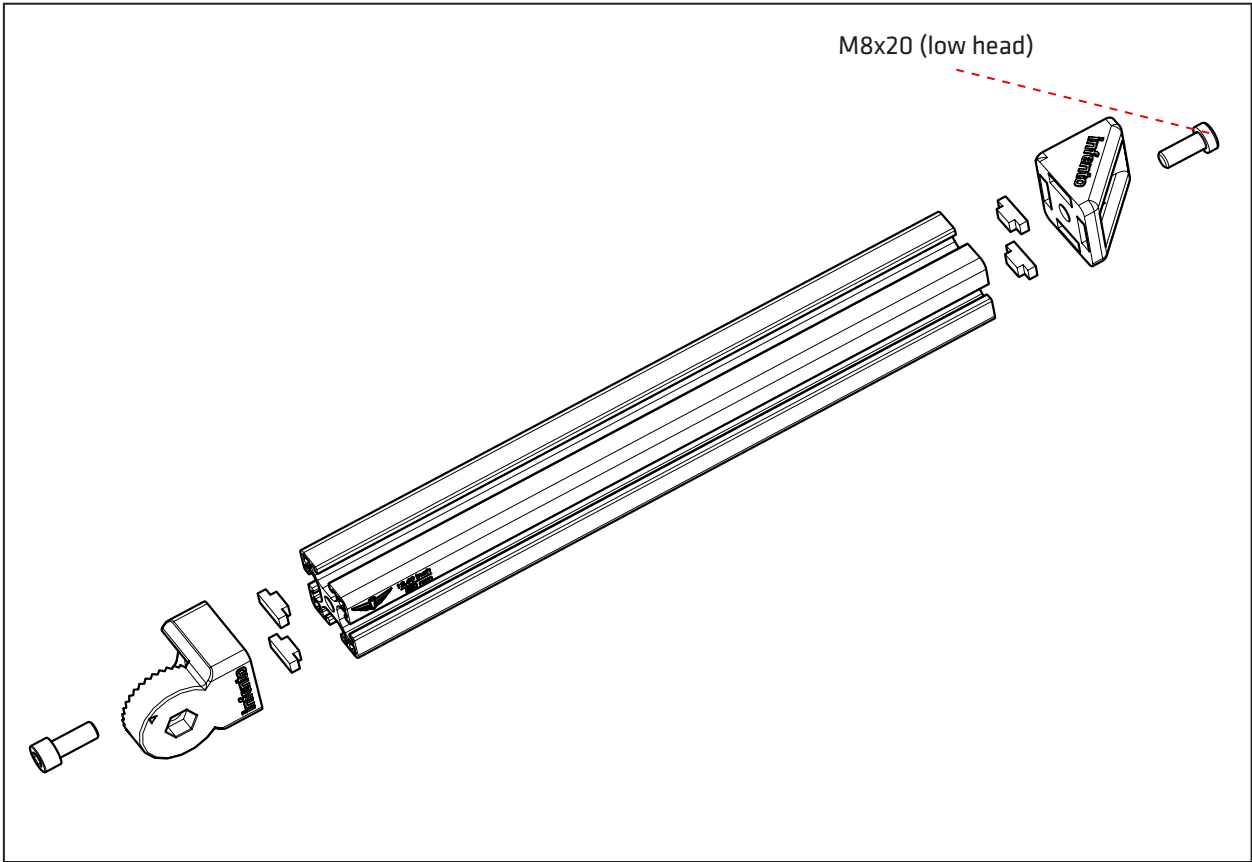



54

ride B-TRIKE

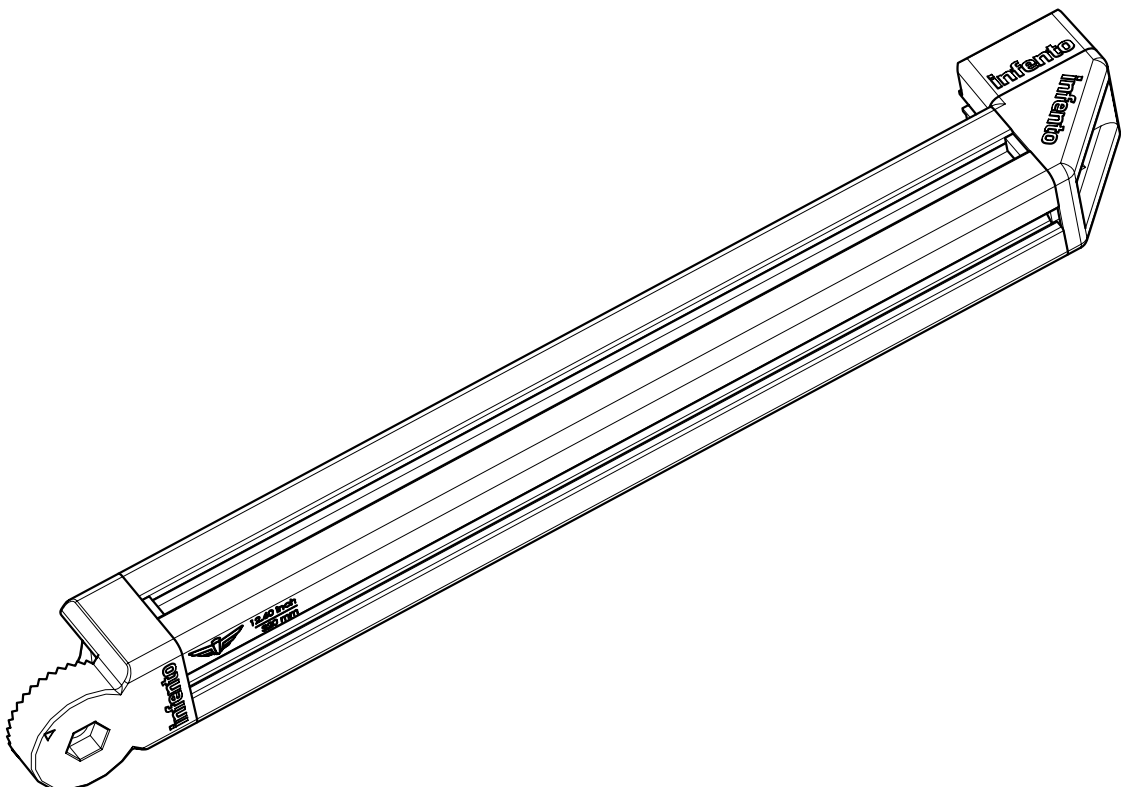
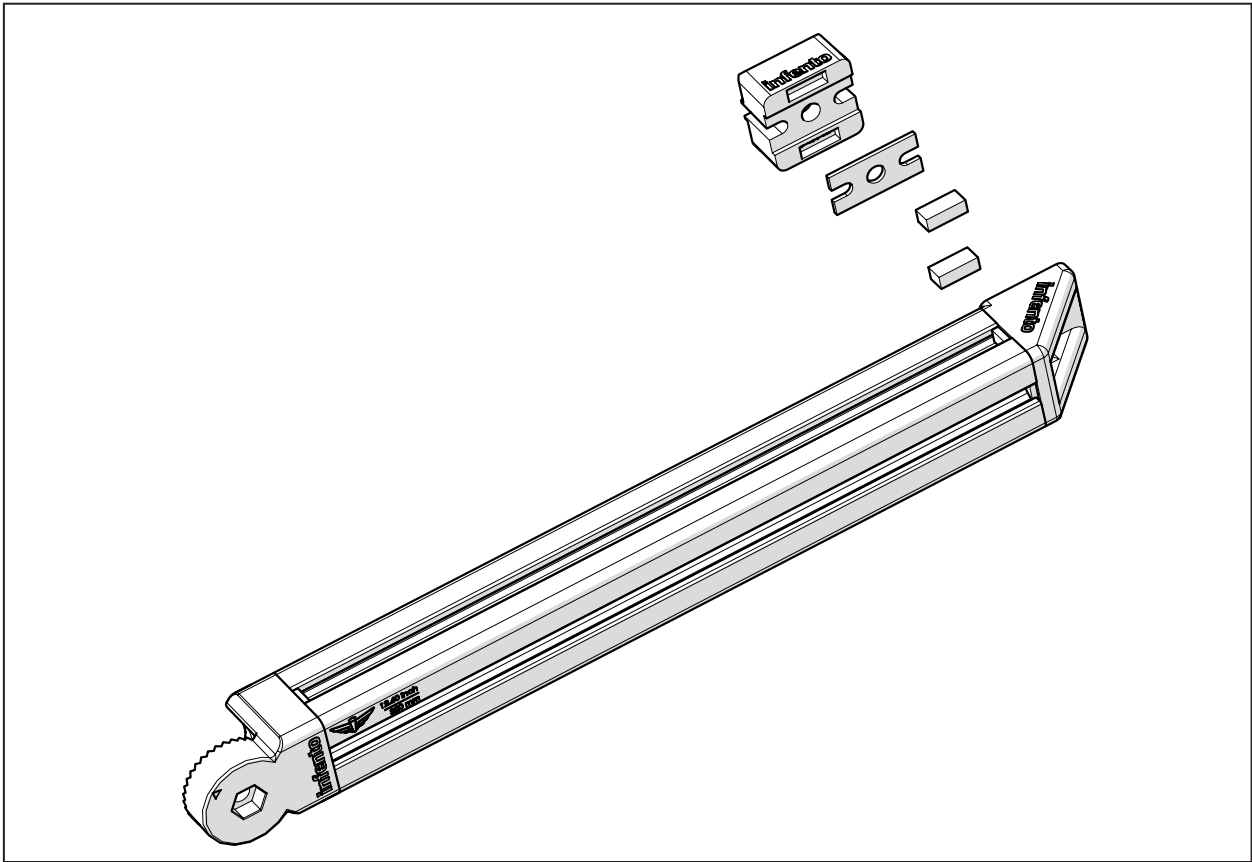
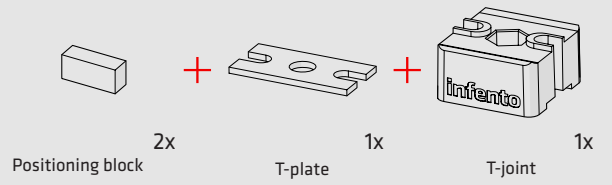



55

ride B-TRIKE

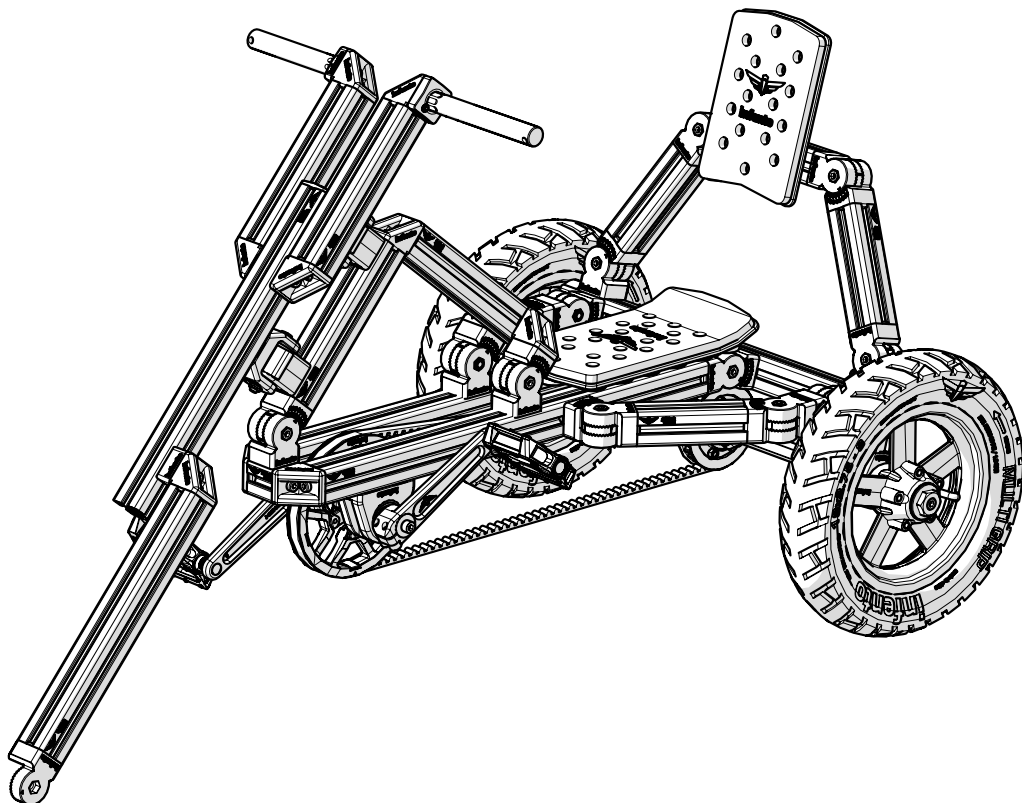
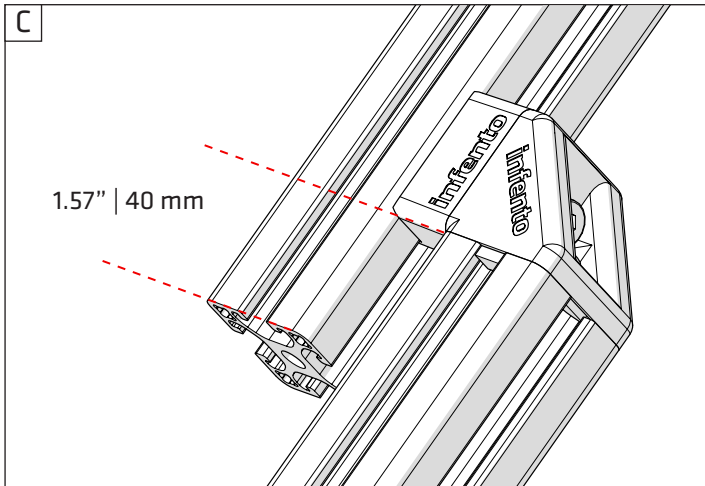
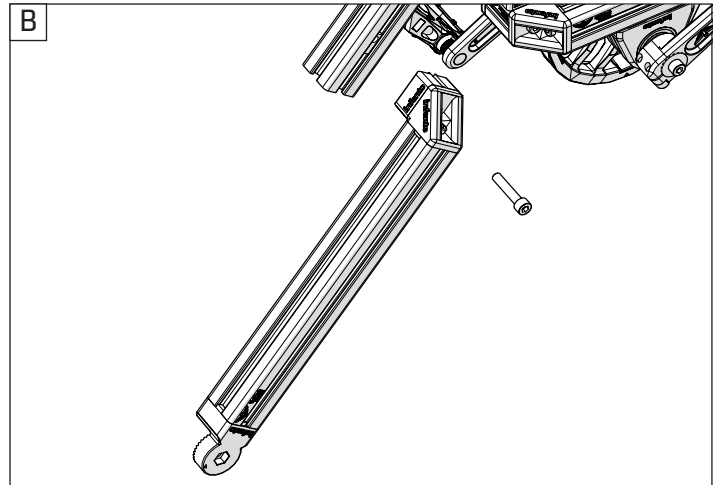
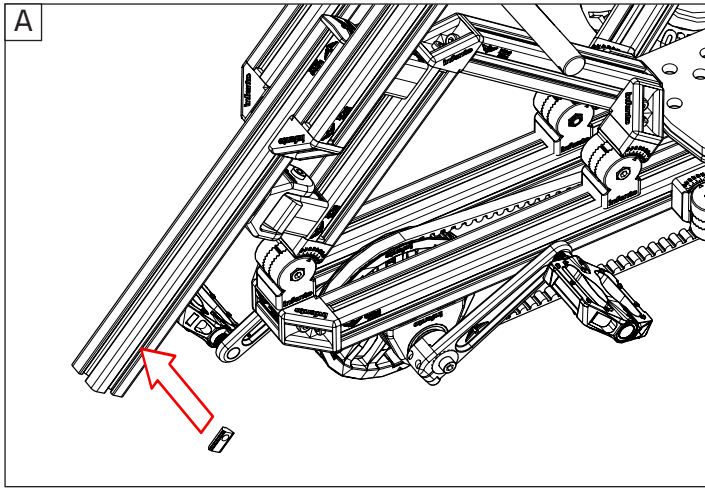
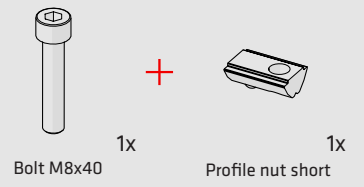



56

ride B-TRIKE

Bolt M8x20
(low head) 1x



T-Positioning block 4x

Bolt M8x20 1x



Multi angle joint 1x

L-joint 1x

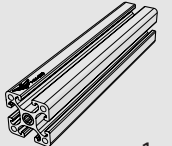

Profile 12.60inch | 320mm 1x

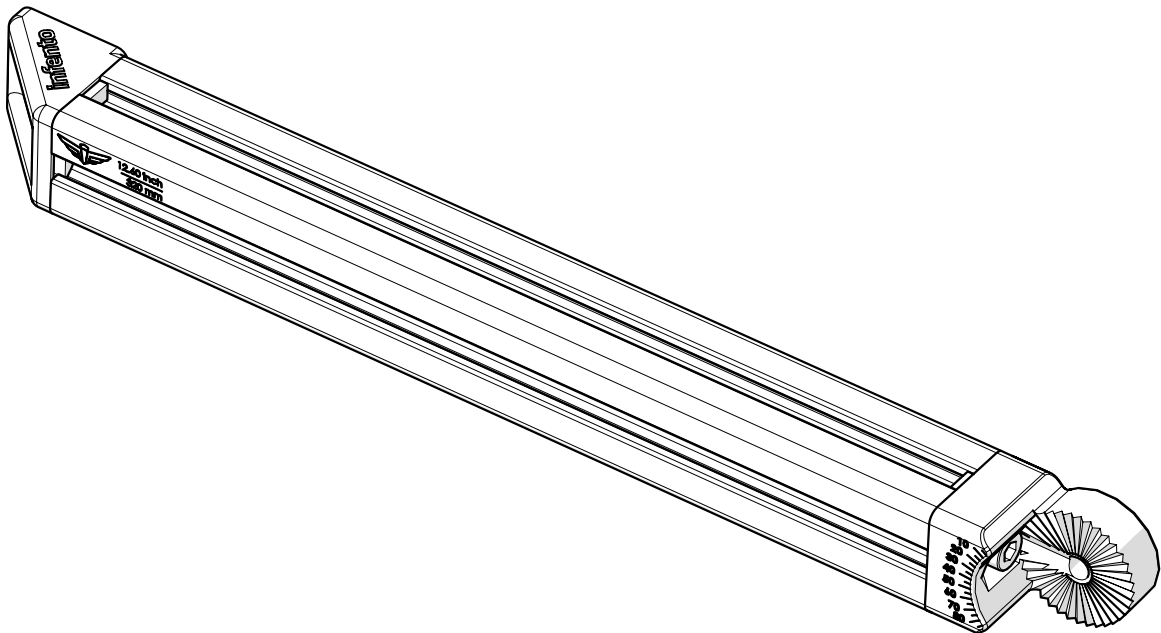
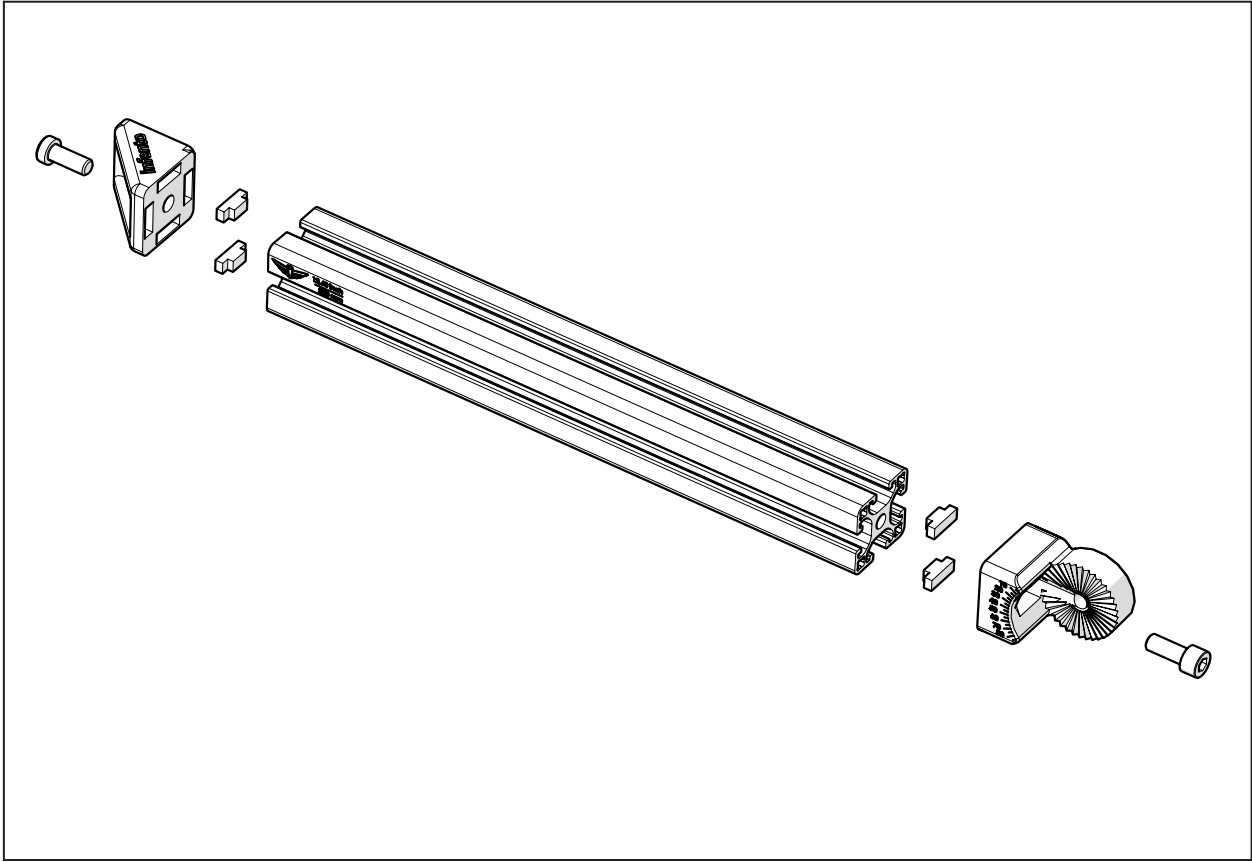



57

ride B-TRIKE

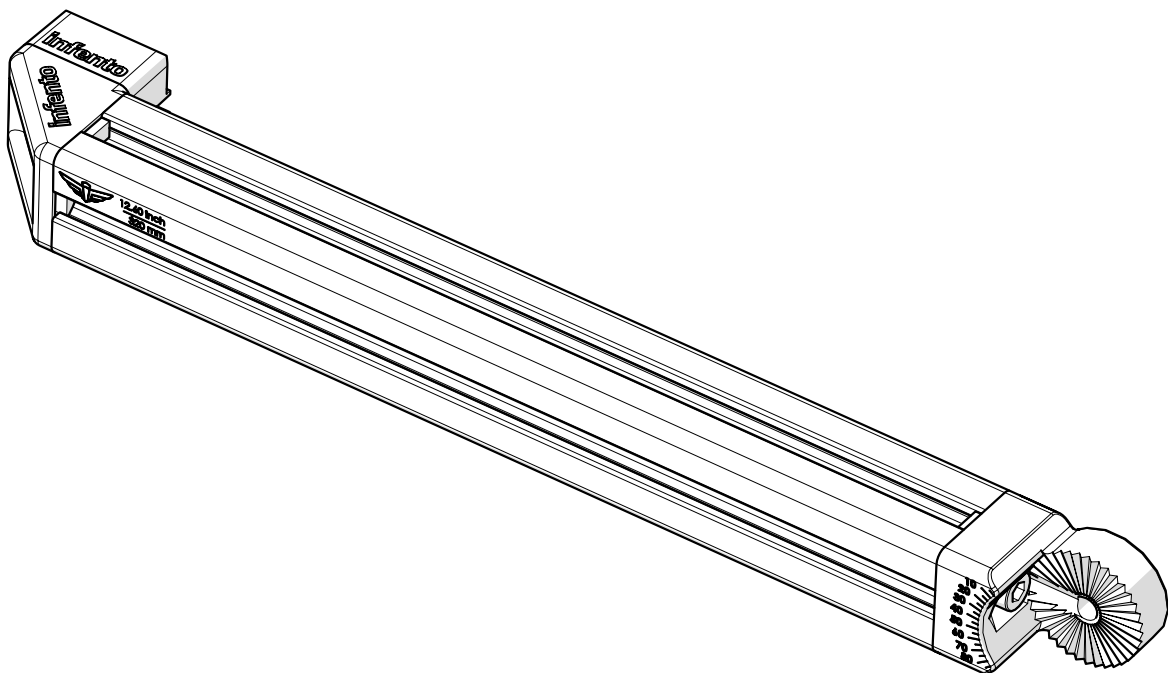
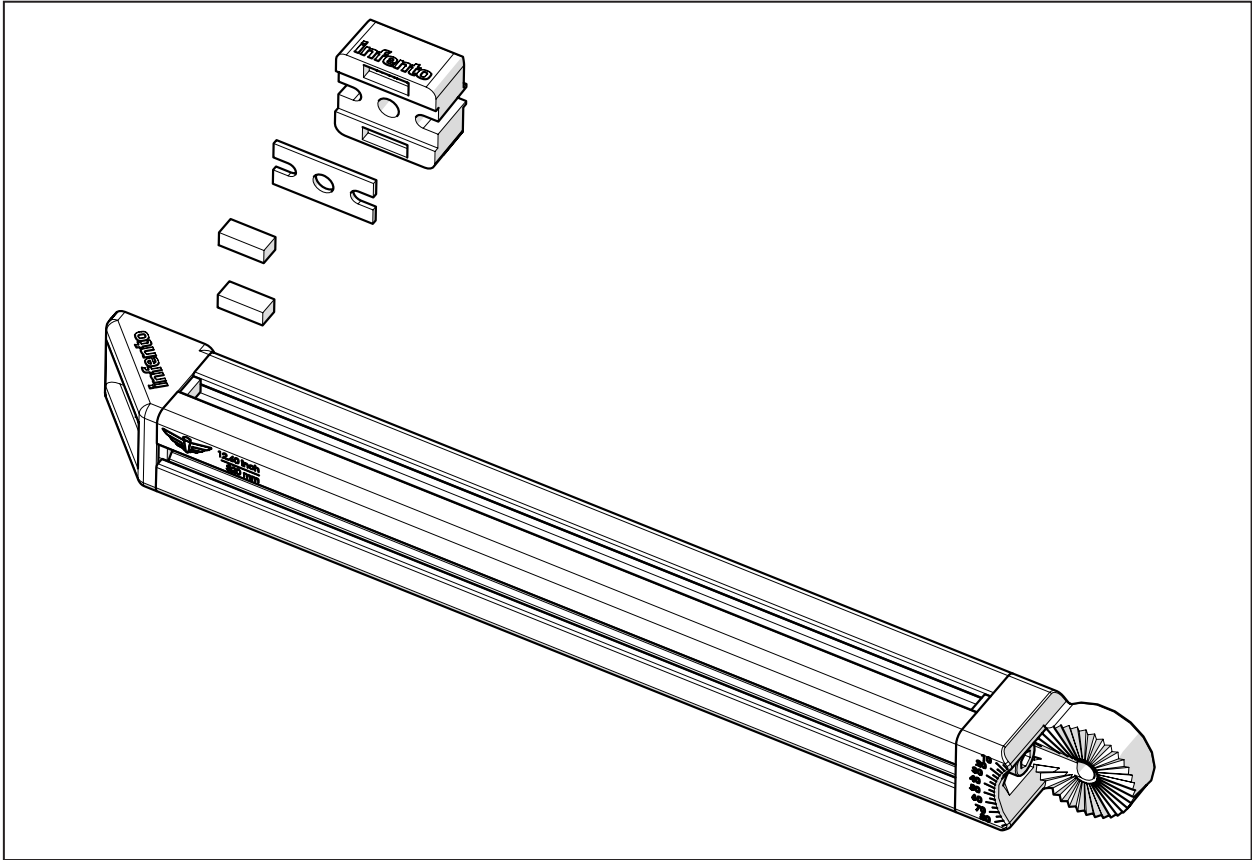
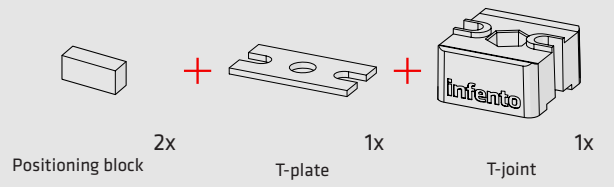



58

ride B-TRIKE

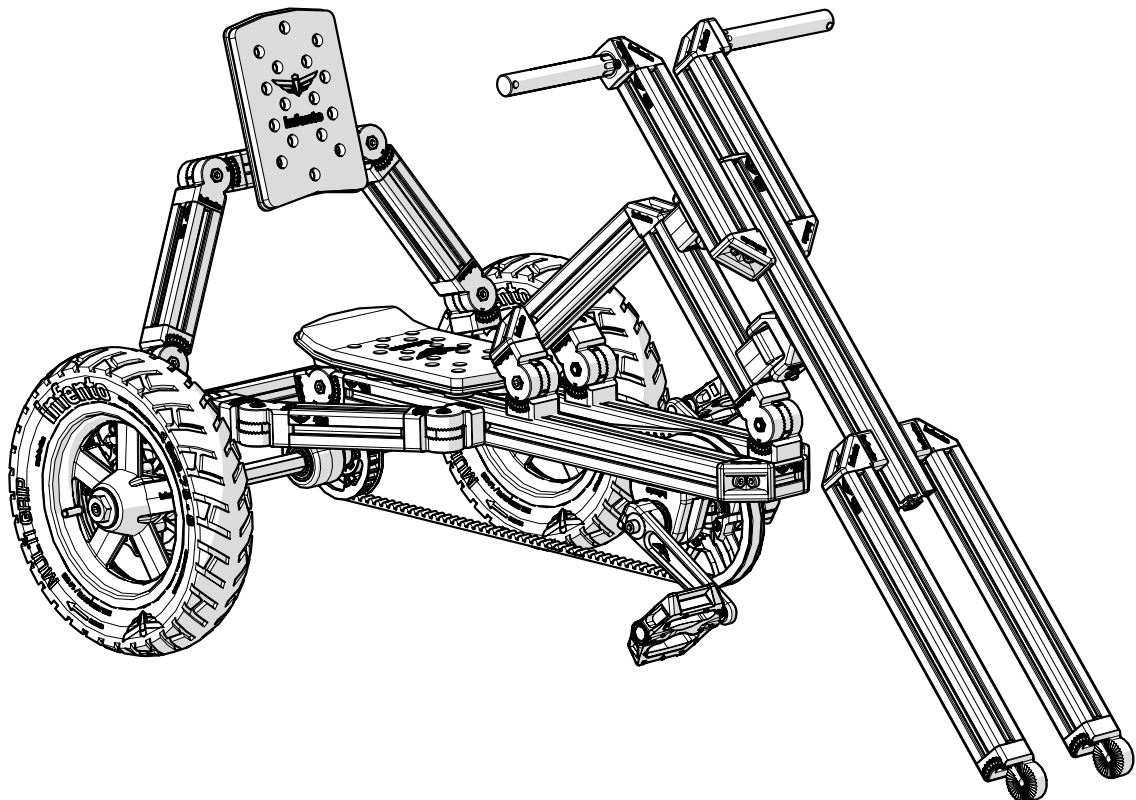
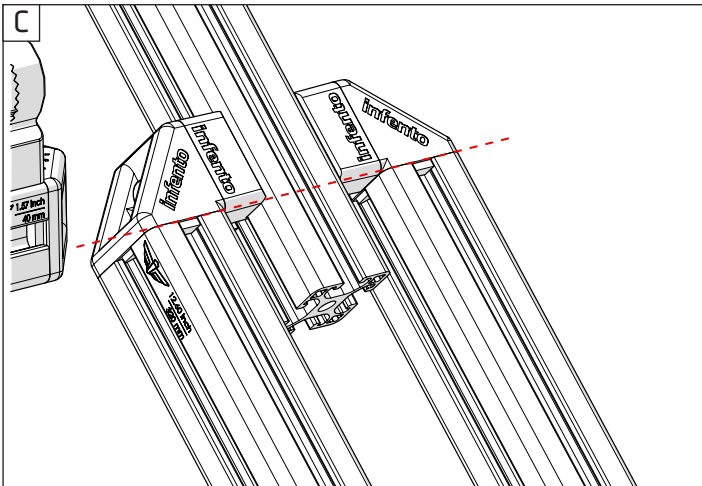
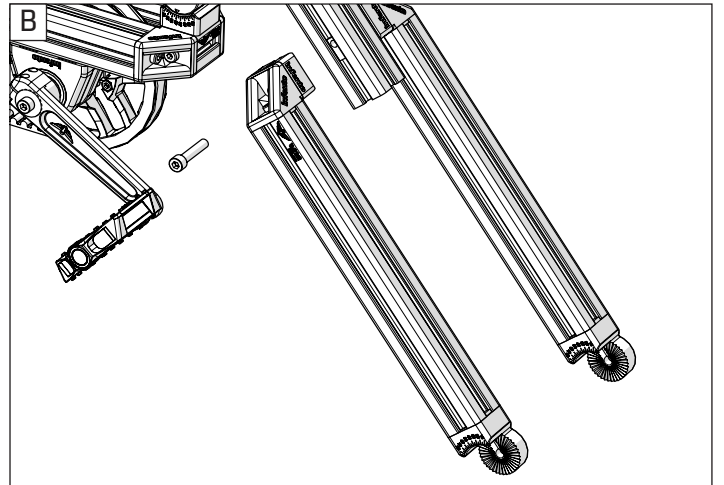
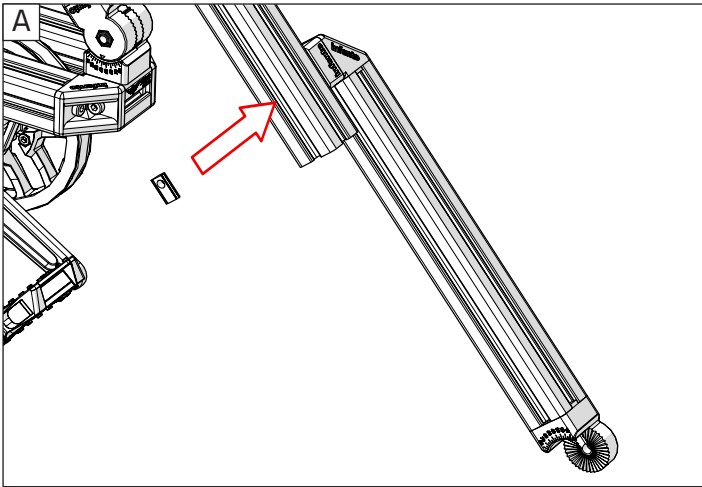
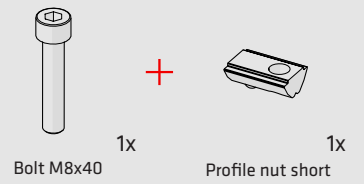



59

ride B-TRIKE



+



+



4x
T-Positioning block

1x
Bolt M8x20
(low head)

1x
L-joint

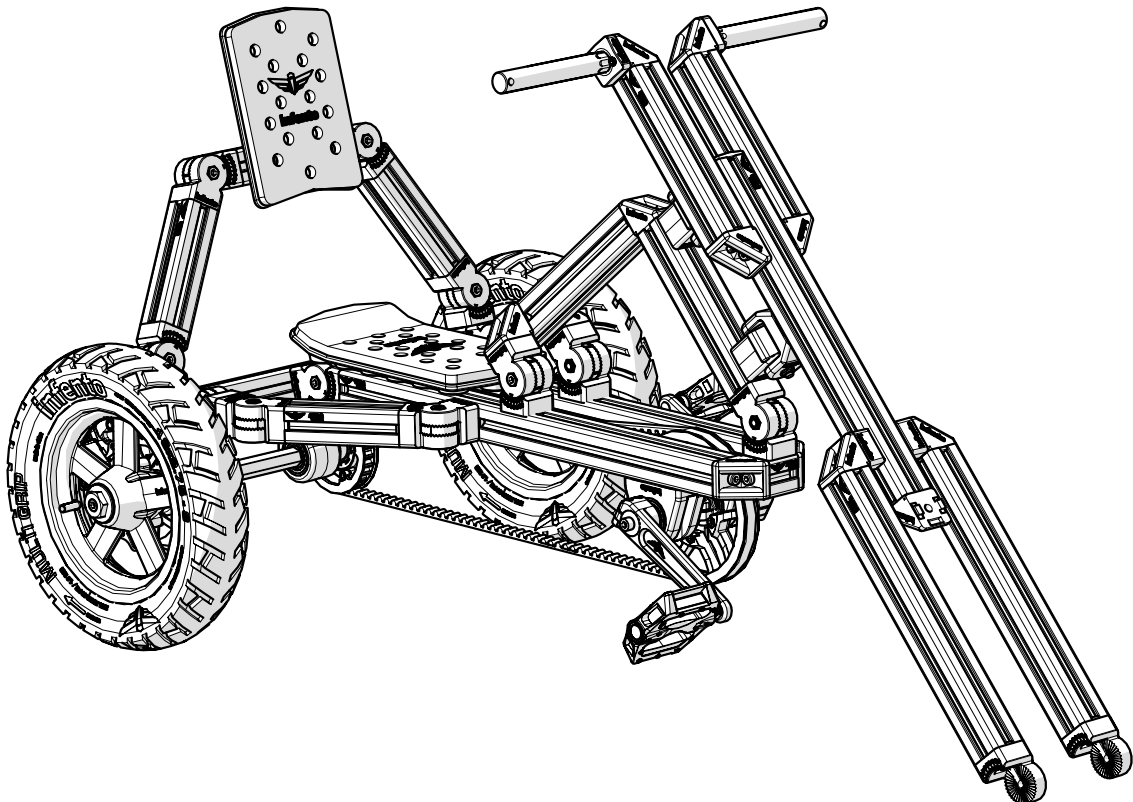
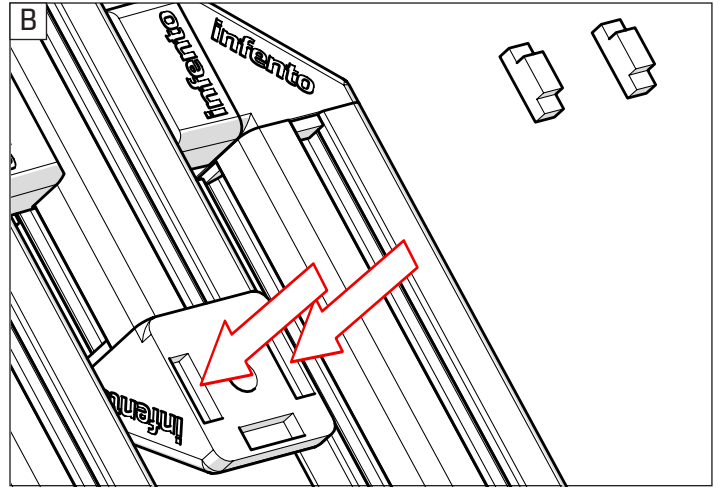
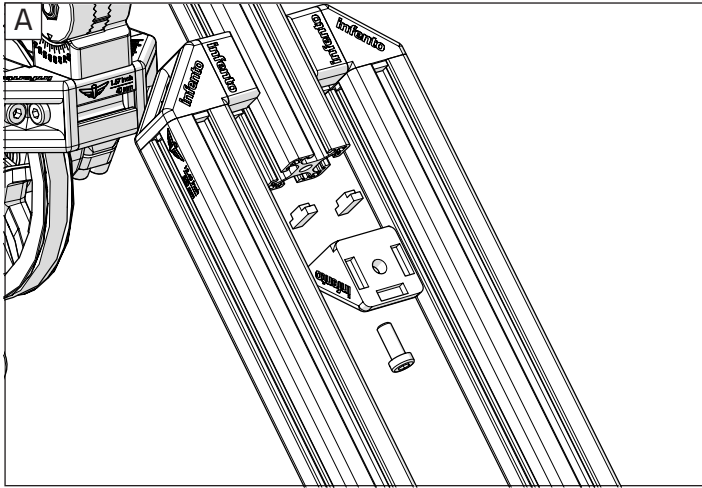



60

ride B-TRIKE

- 1x Profile nut short + 8x T-Positioning block + 2x Bolt M8x20 (low head) + 2x L-joint + 1x Profile 3.15inch | 80mm

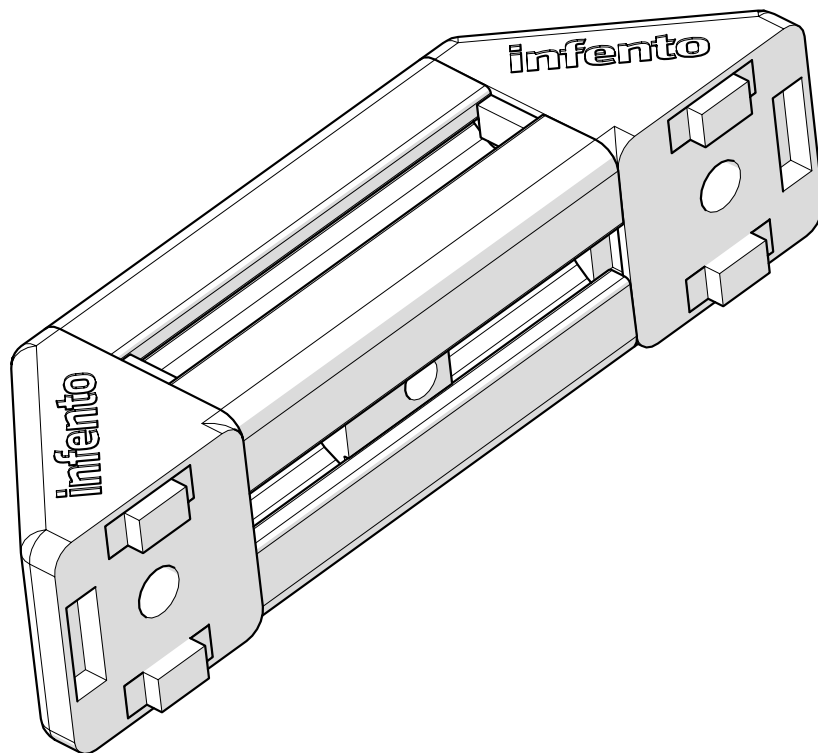
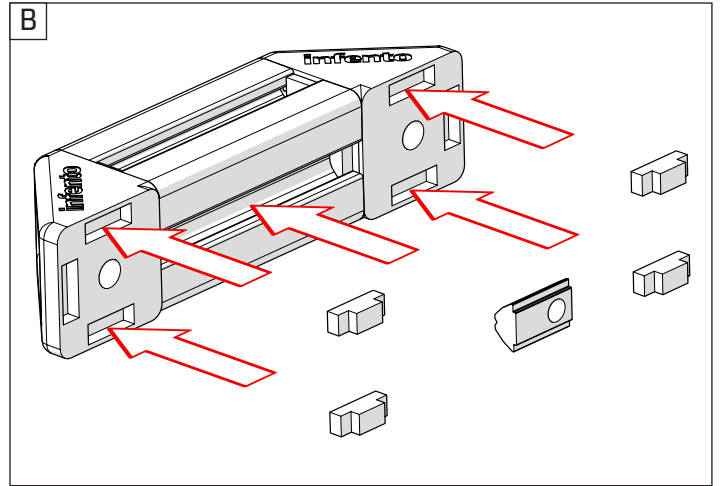
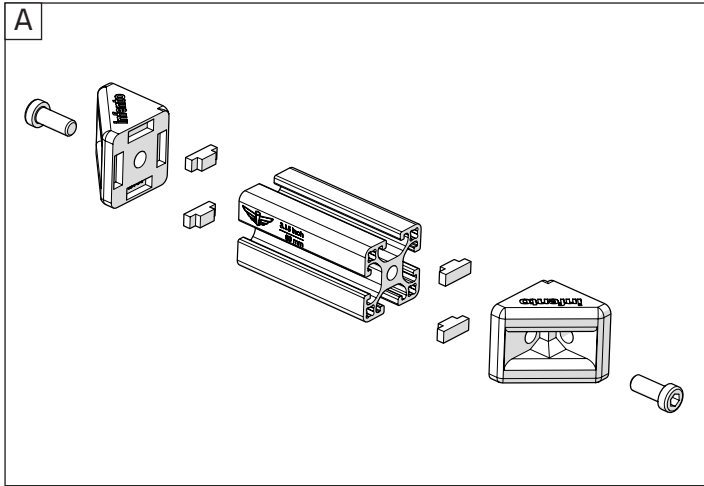



61

ride B-TRIKE



Bolt M8x20 3x
(low head)



Profile nut short 2x

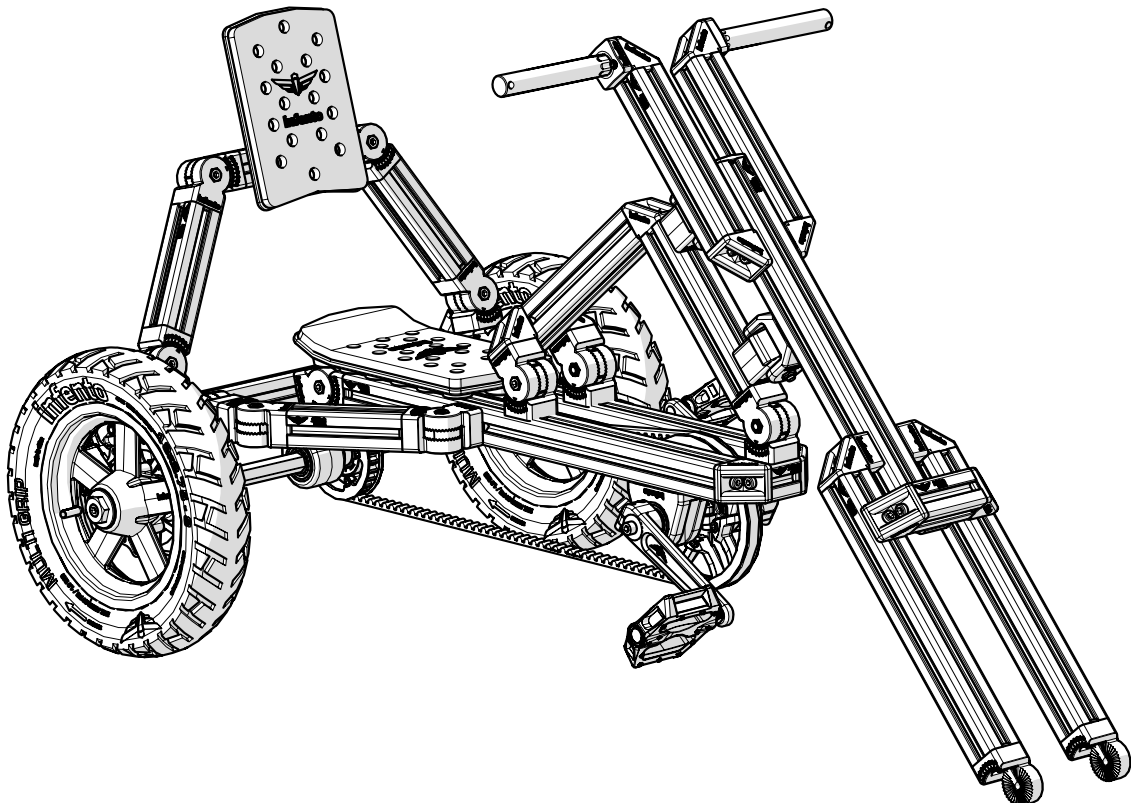
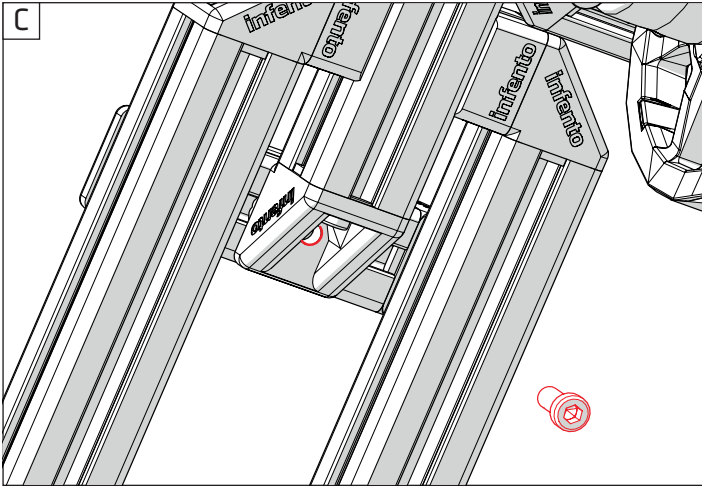
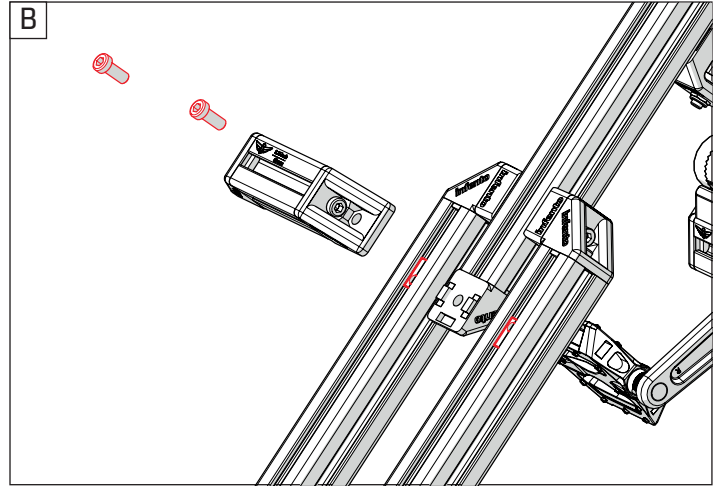
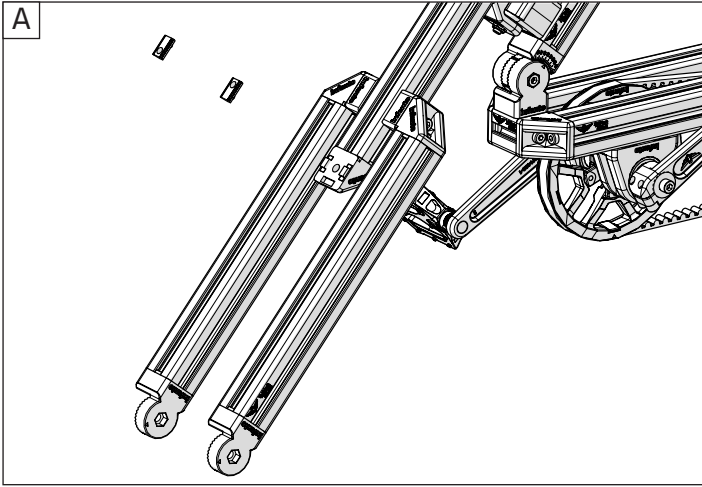



62

ride B-TRIKE

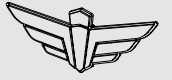

1x

Emblem

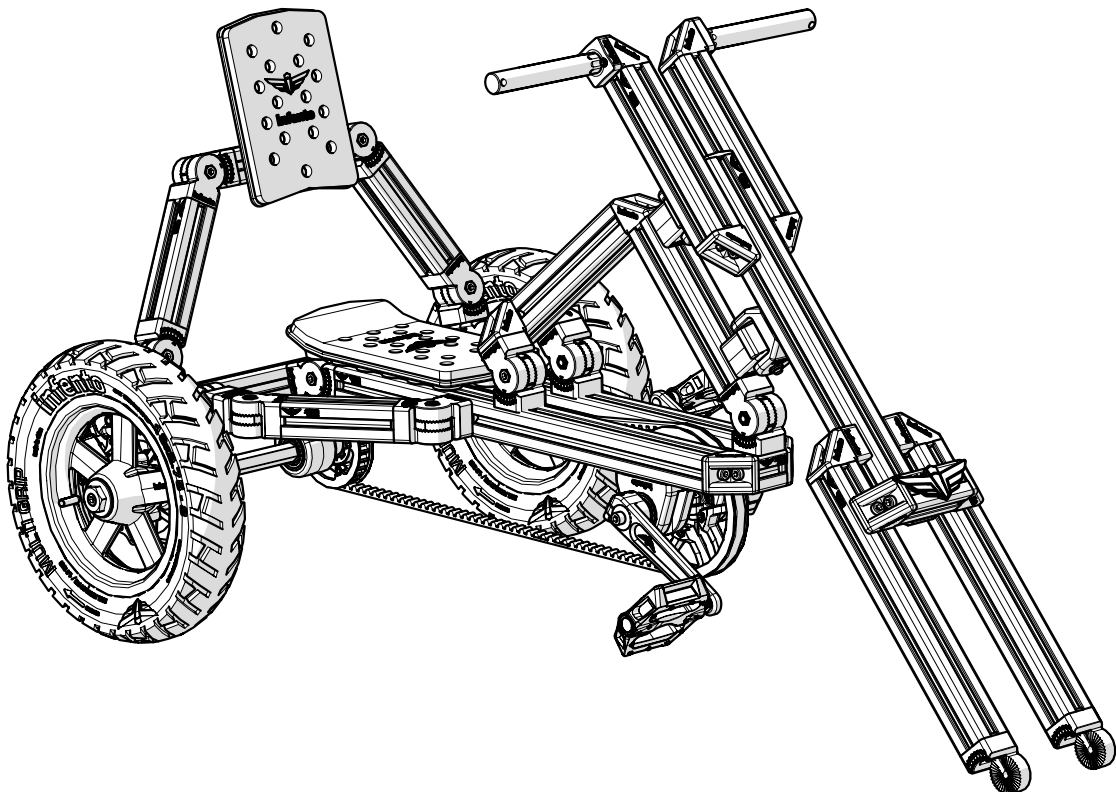
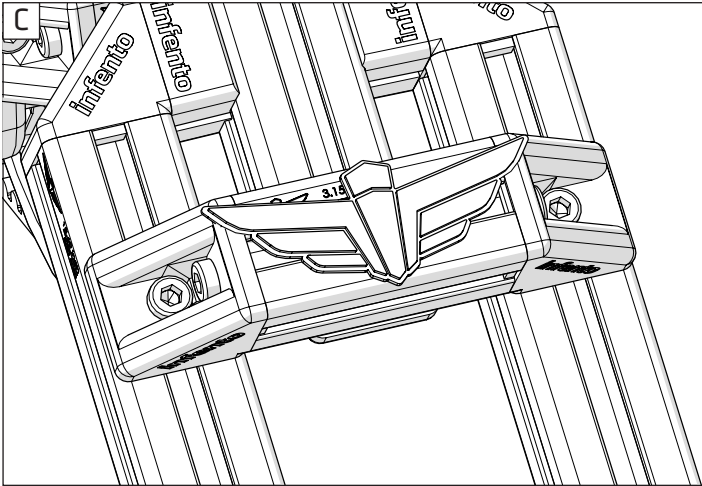
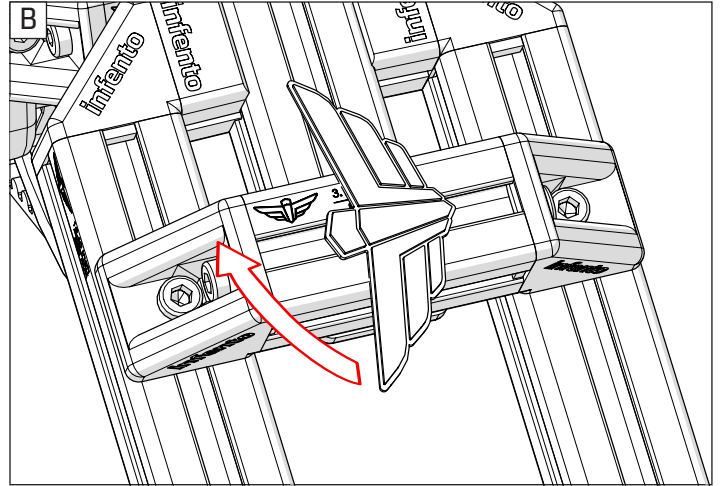
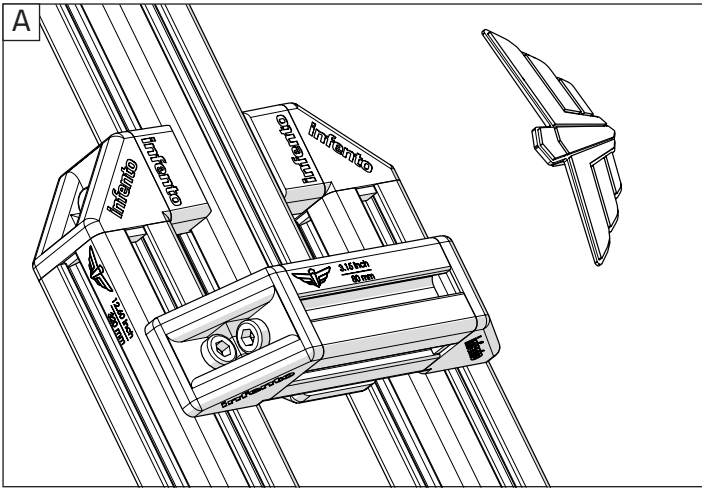



63

ride B-TRIKE



2x

Locknut M8

+



4x

Positioning block

+



2x

Bolt M8x25

+



2x

Axle clamp

+

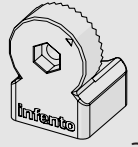

2x

Multi angle joint

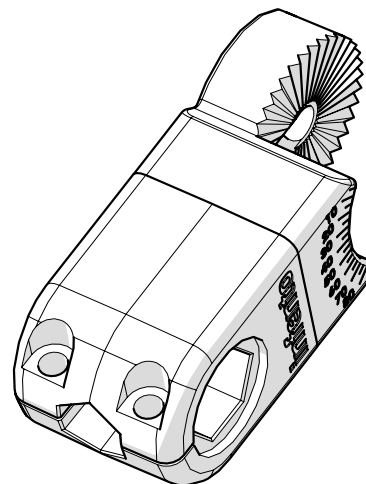
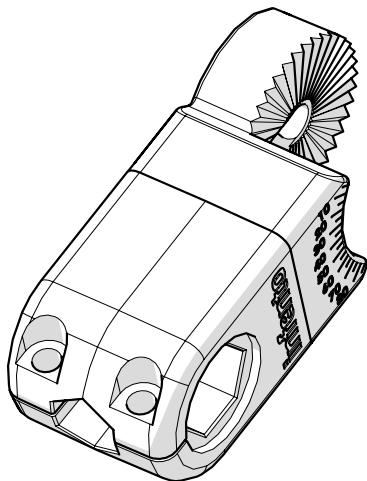
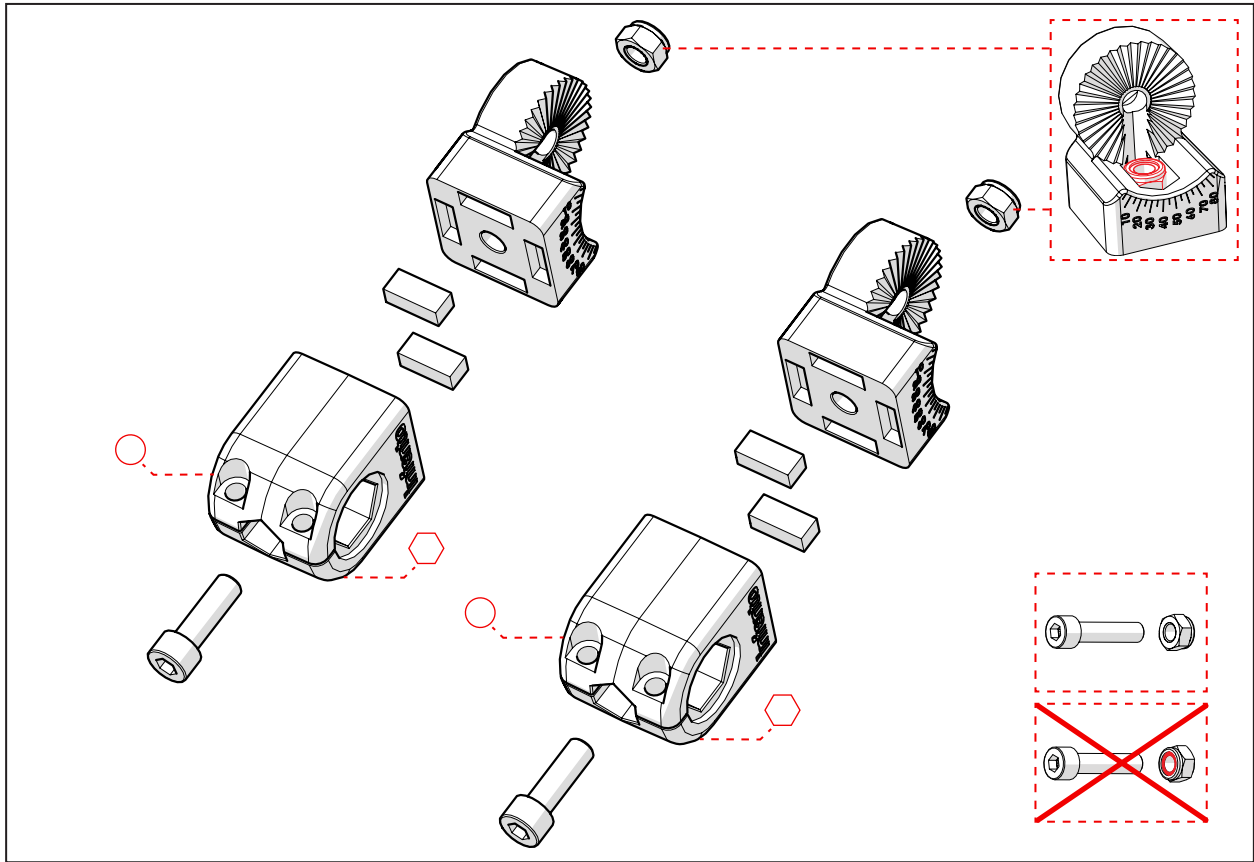



64

ride B-TRIKE

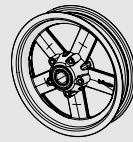

8 inch
Free spinning rim 1x

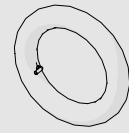

Inner tube 1x
13x2.75-8



Tire 1x
13x2.75-8

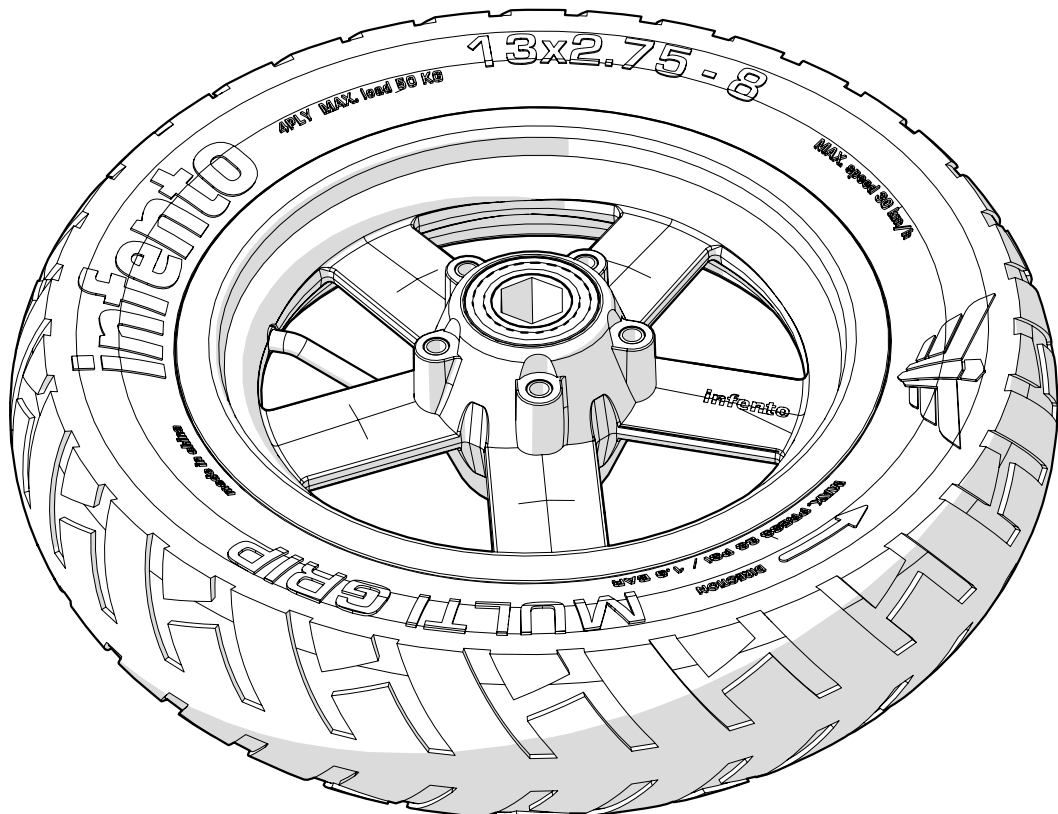
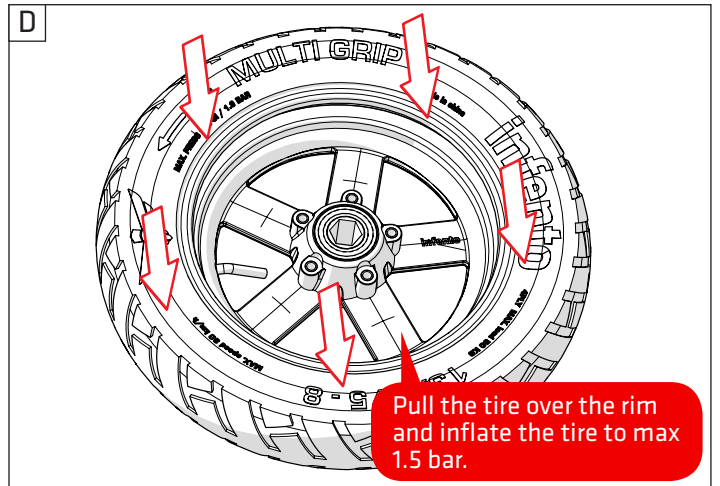
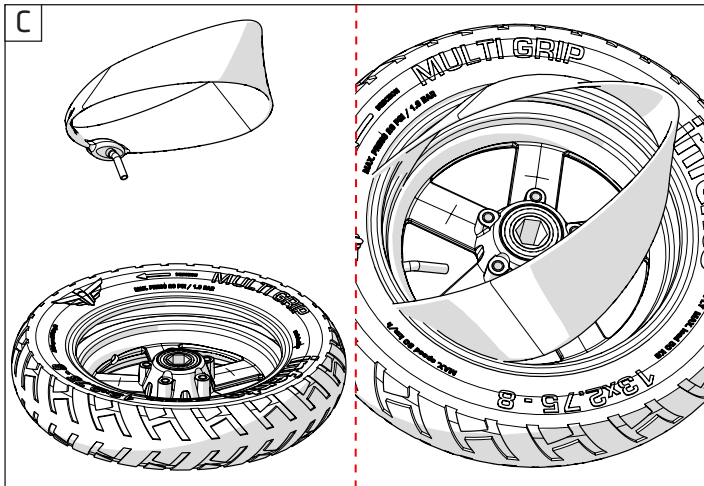
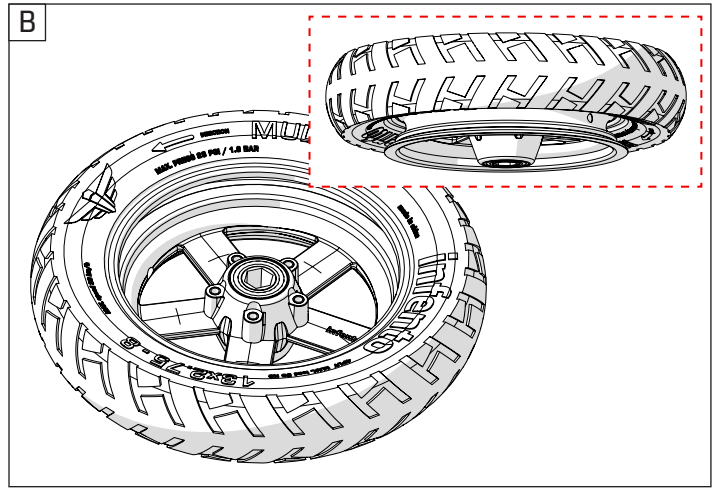
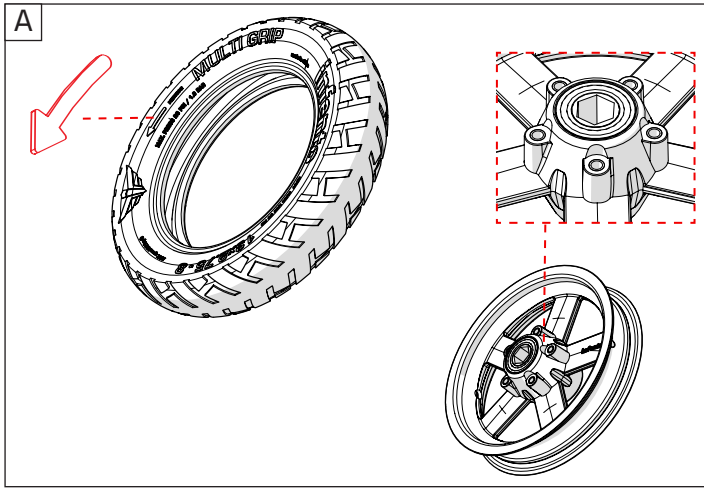



65

ride B-TRIKE

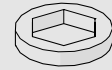

Spacer 2x
0.2inch | 5 mm



Axle 1x
6.06inch | 154mm

A

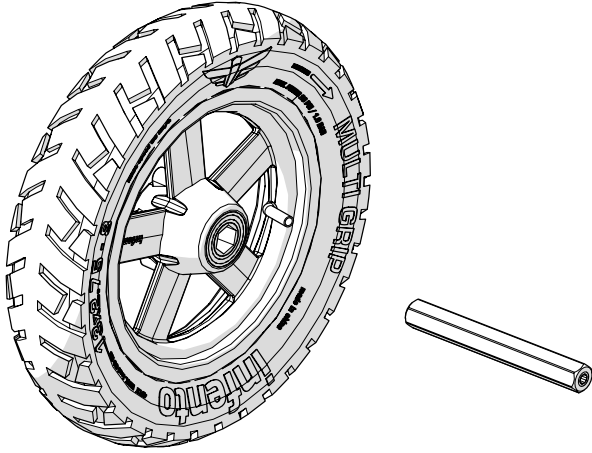

B



C

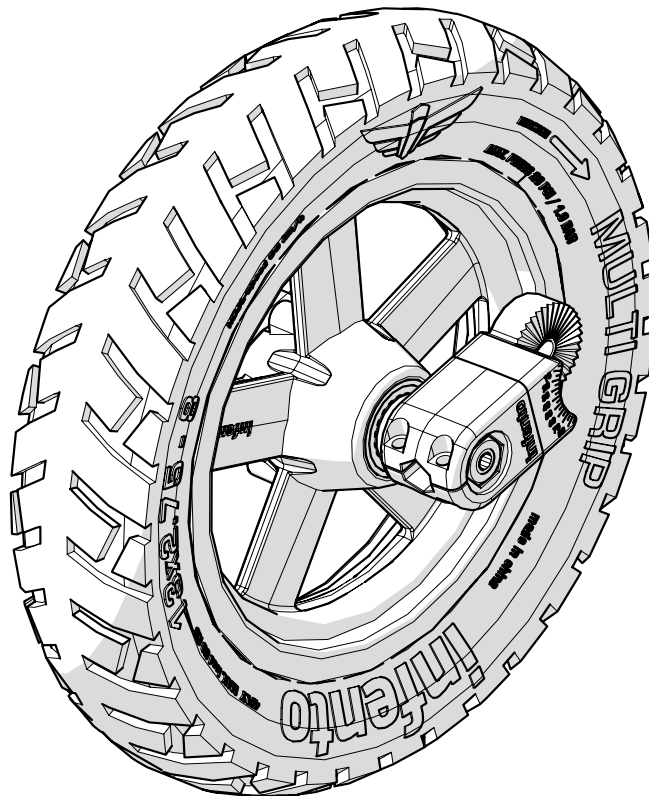
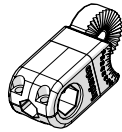
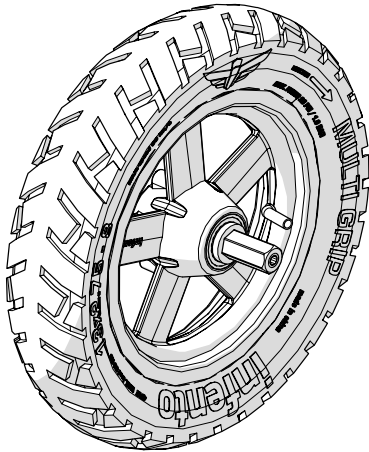
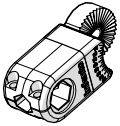



66

ride B-TRIKE



2x

Locknut M8

+



2x

Bolt M8x35

+

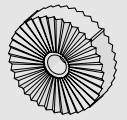

2x



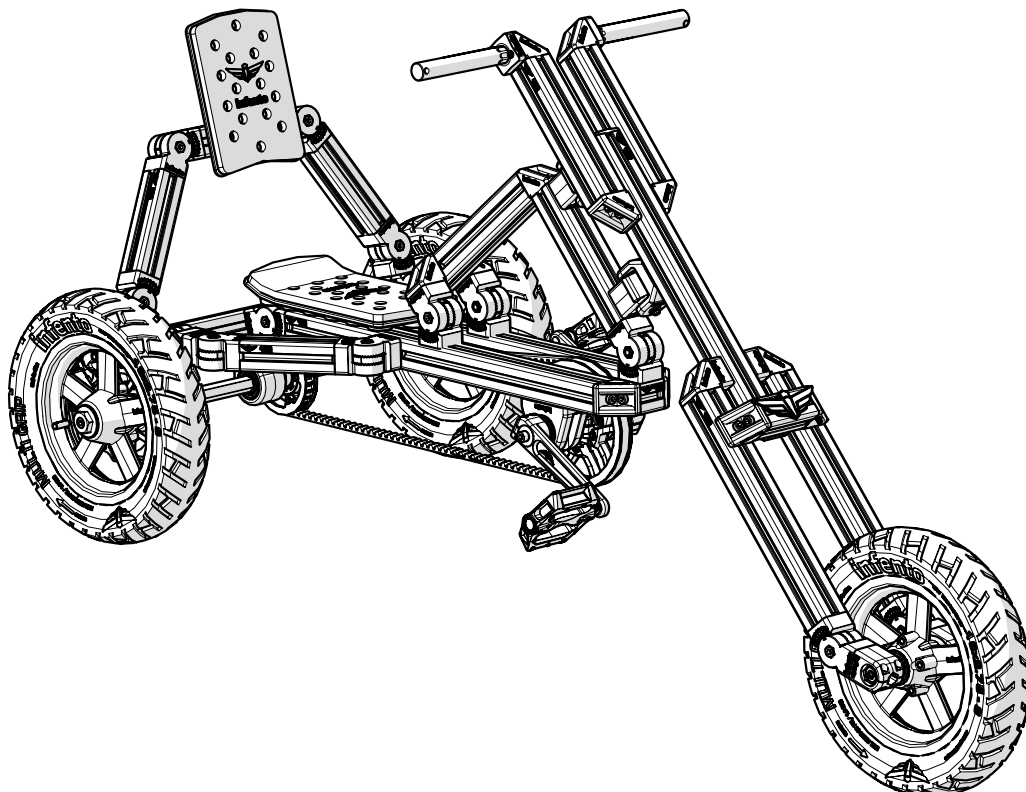
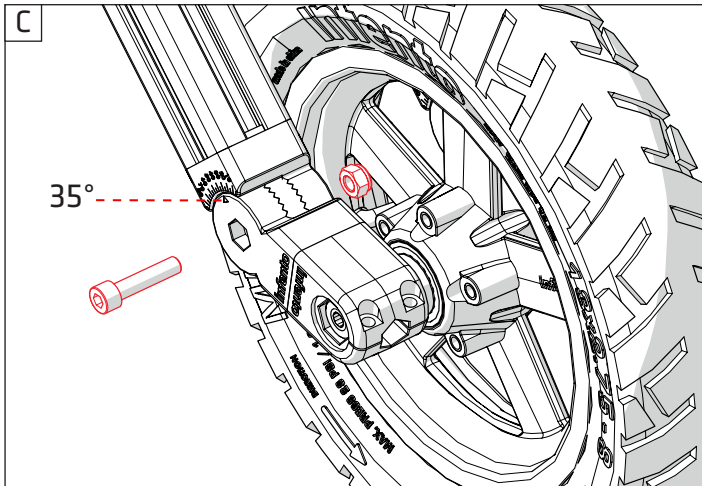
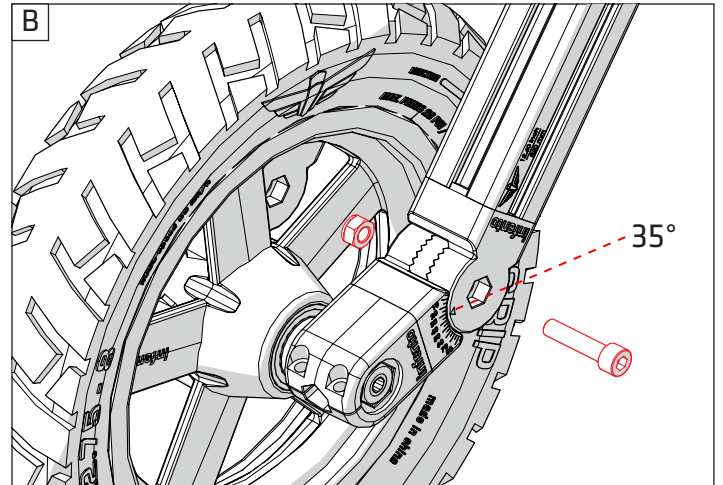
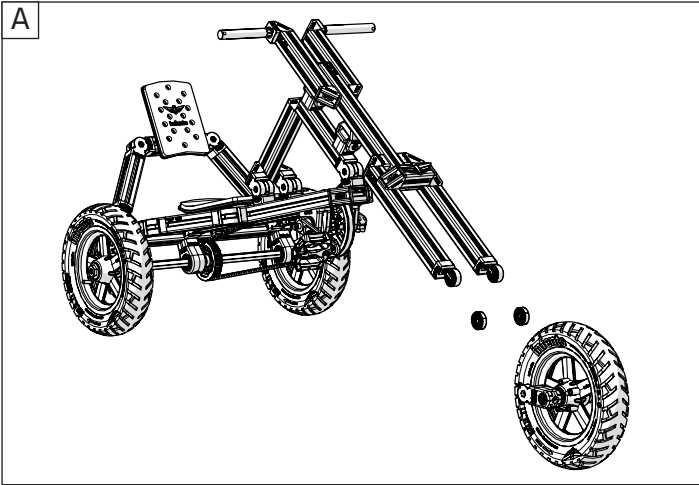

Knurled disc 1 stripe





67

ride B-TRIKE

- | | | | | | | | |
|--|----|---|----|--|----|--|----|
|  | + |  | + |  | + |  | |
| Locknut M6 | 4x | Bolt M6x25 | 4x | Washer M8-24 | 2x | Bolt M8x20 | 2x |

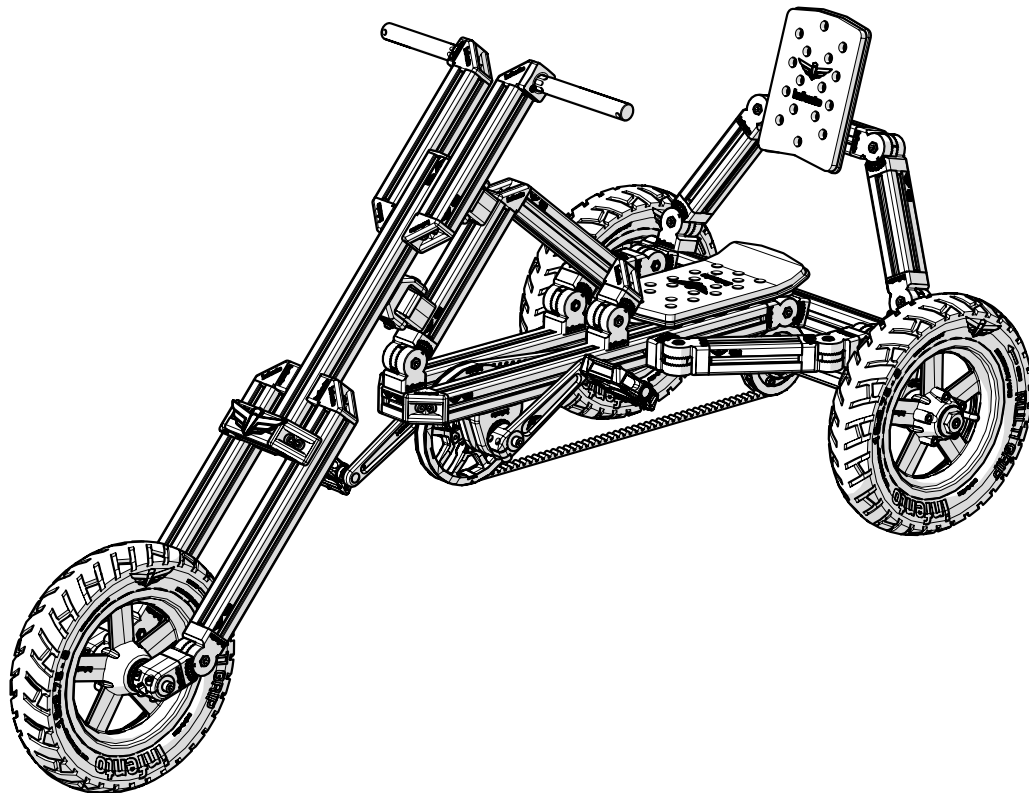
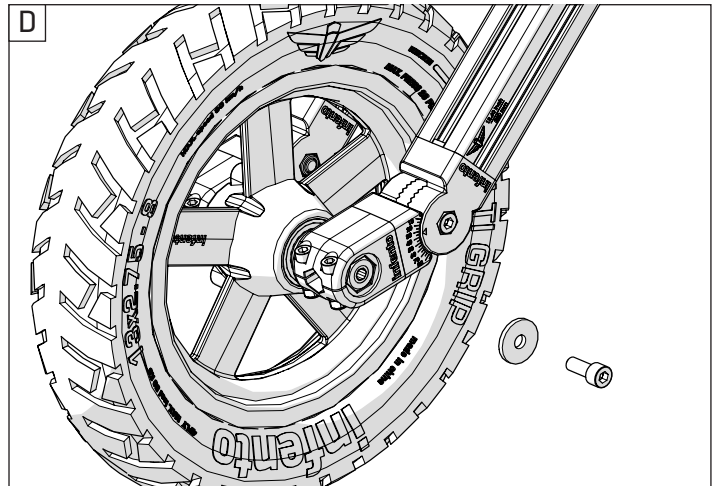
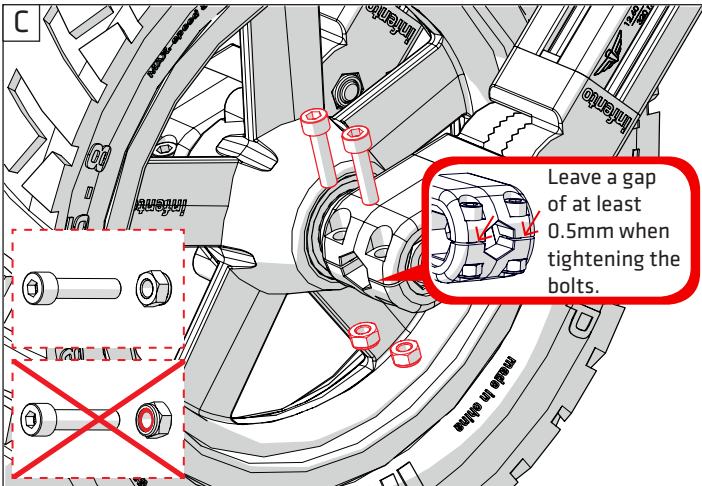
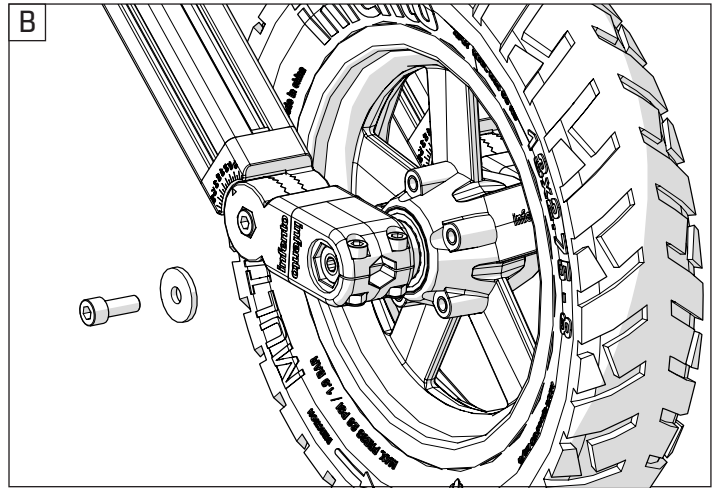
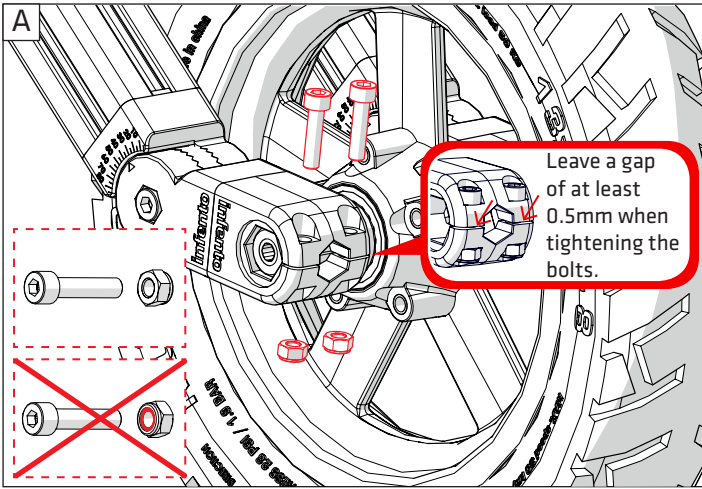



68

ride B-TRIKE

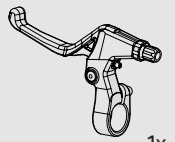

1x
Brake lever left

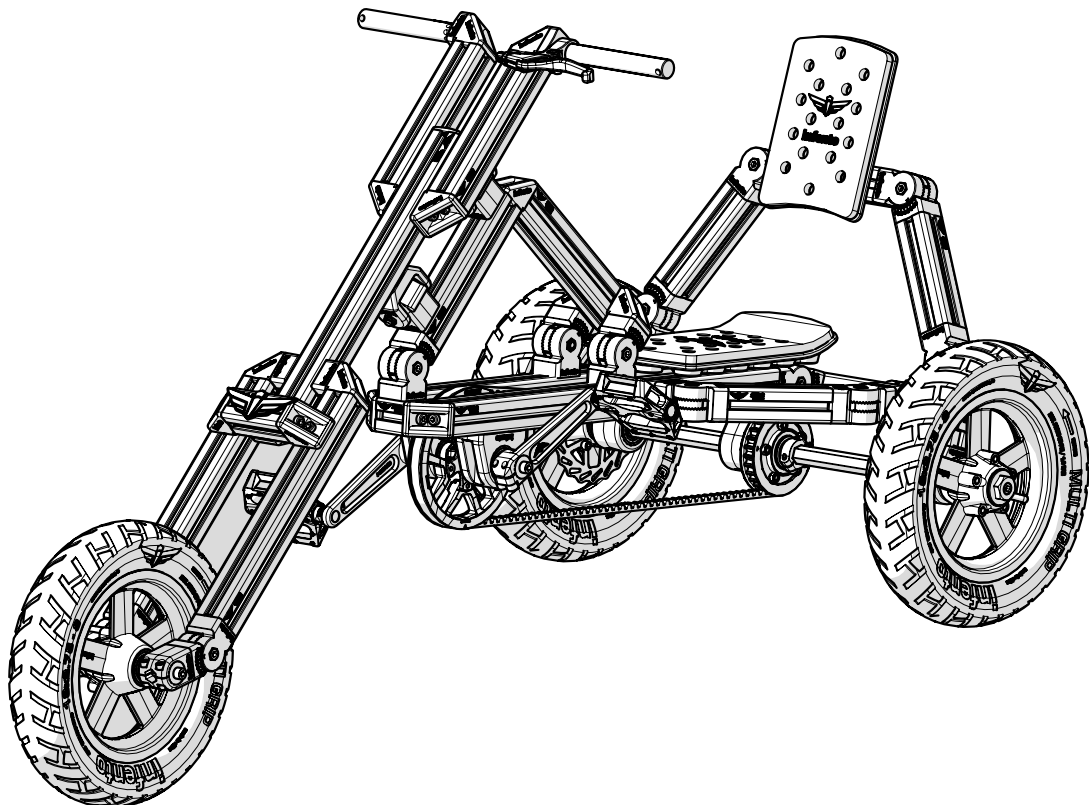
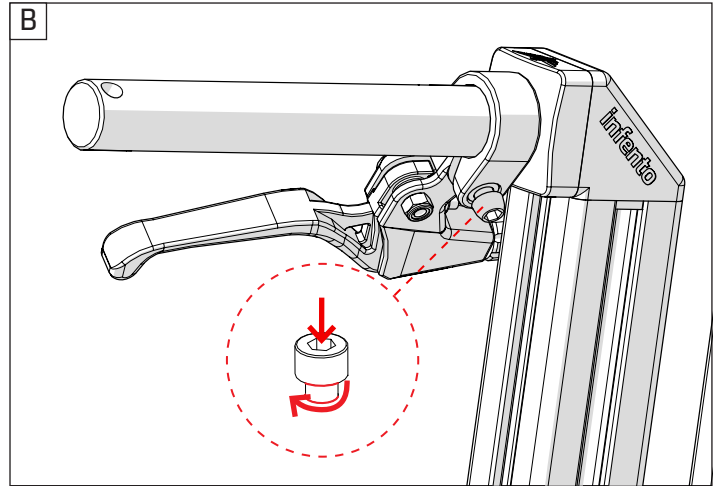
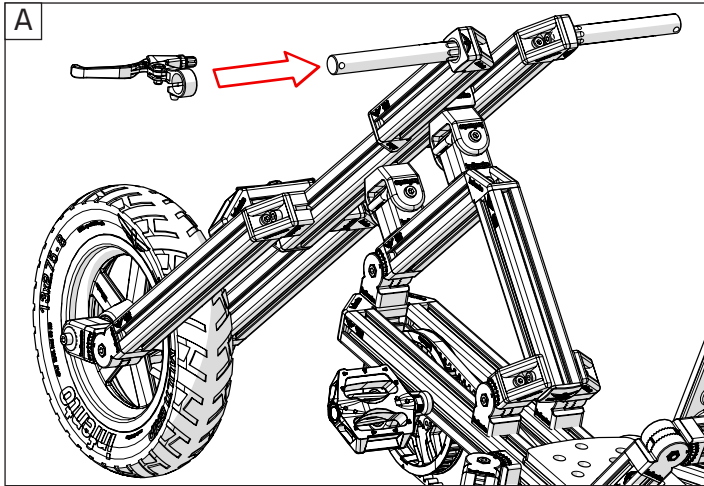



69

ride B-TRIKE

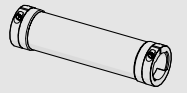

2x

Handgrip

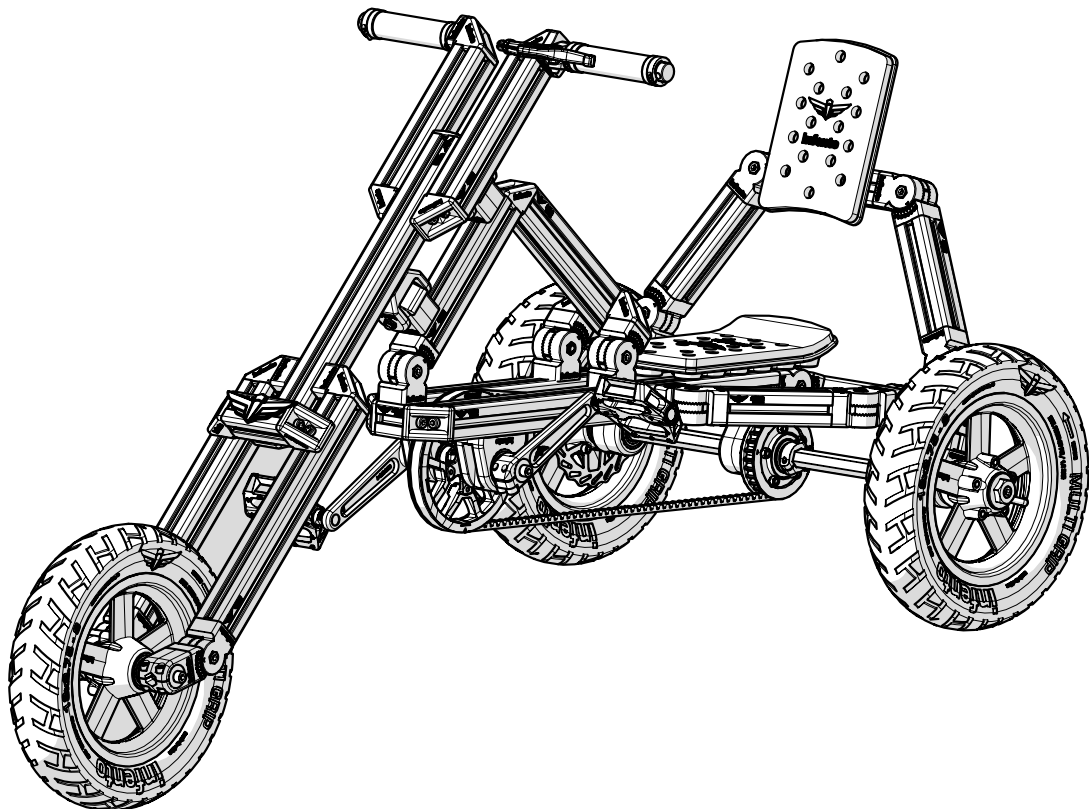
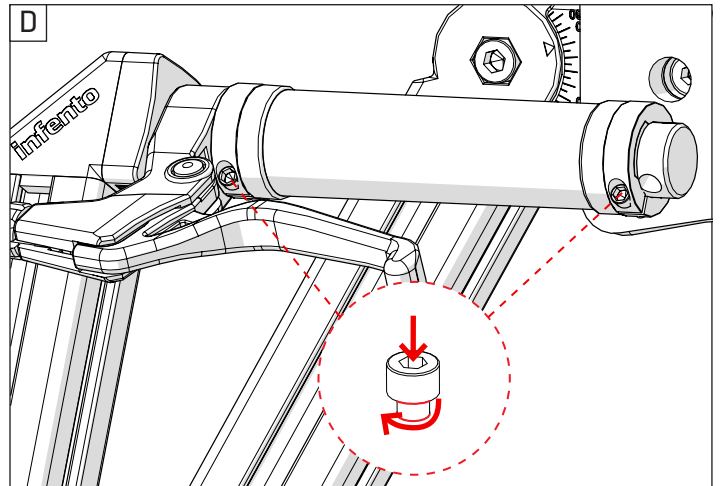
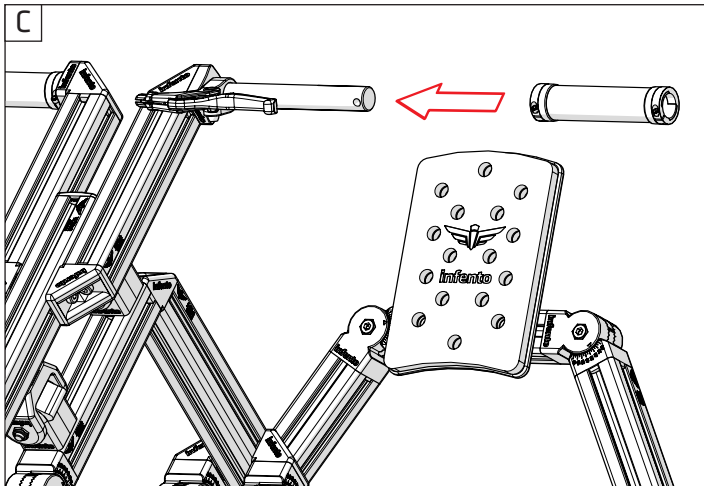
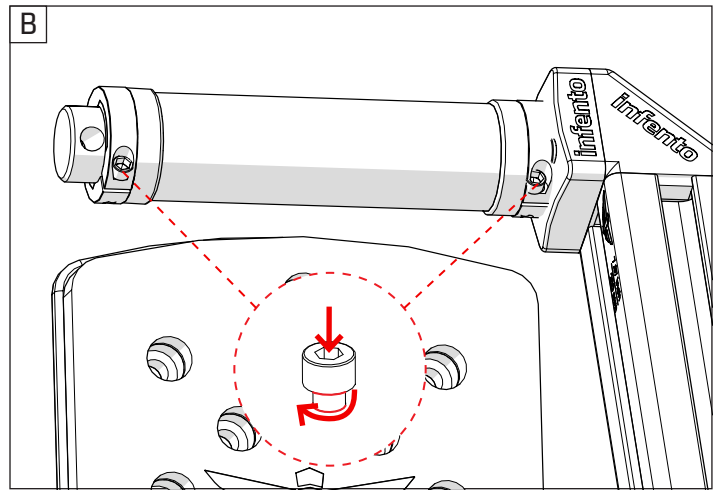
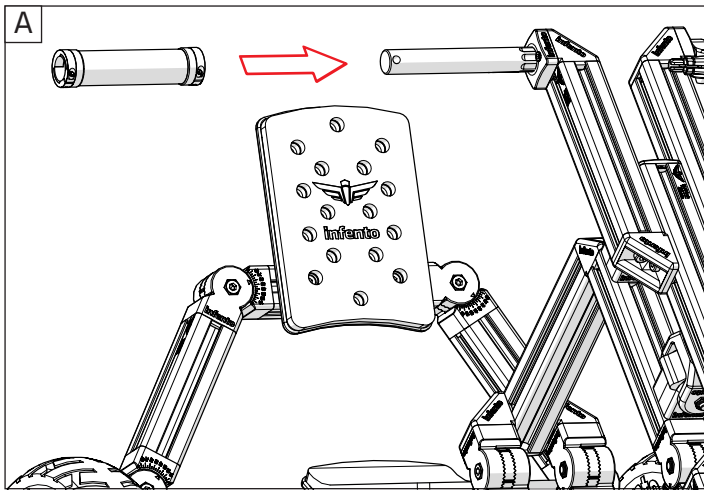



70

ride B-TRIKE

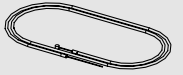

Brake cable 1x
59.06 in | 1500 mm

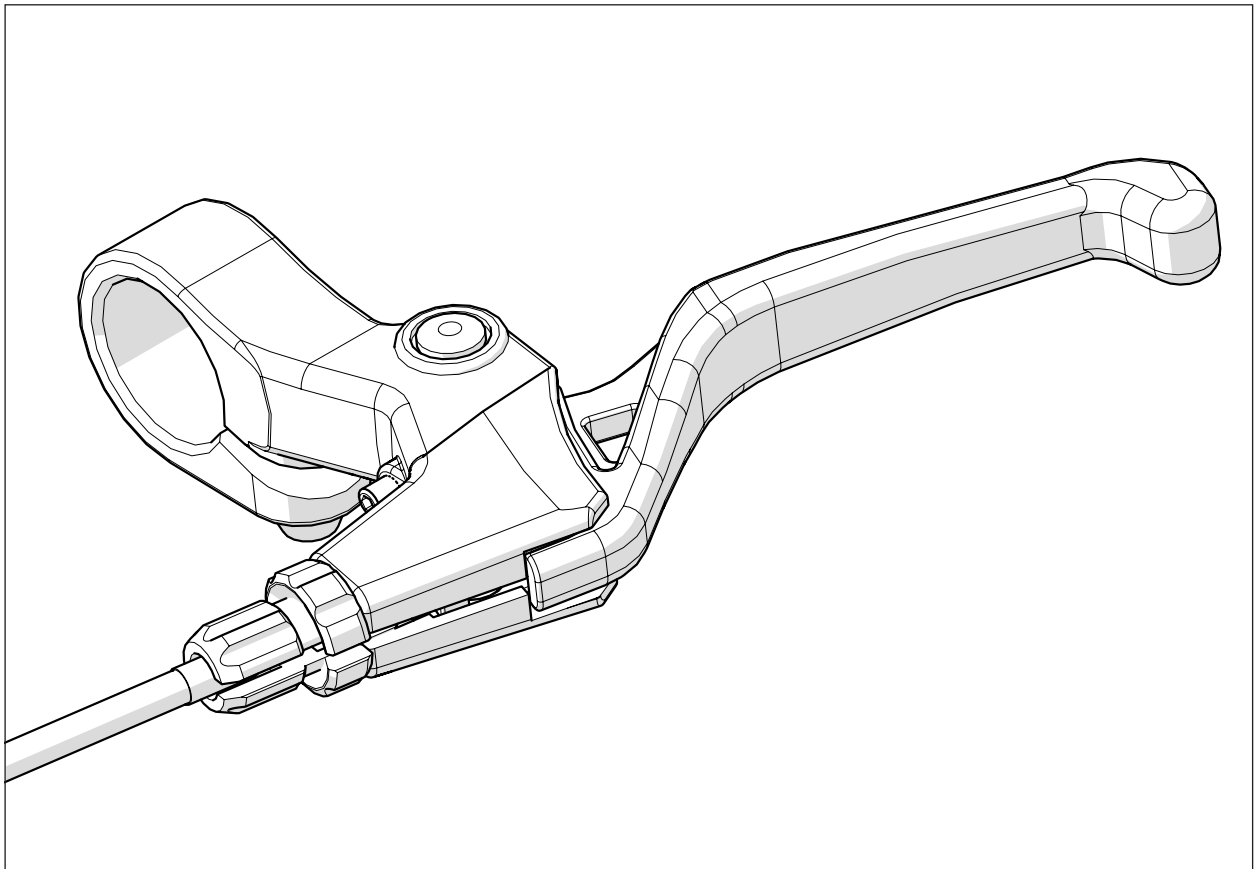
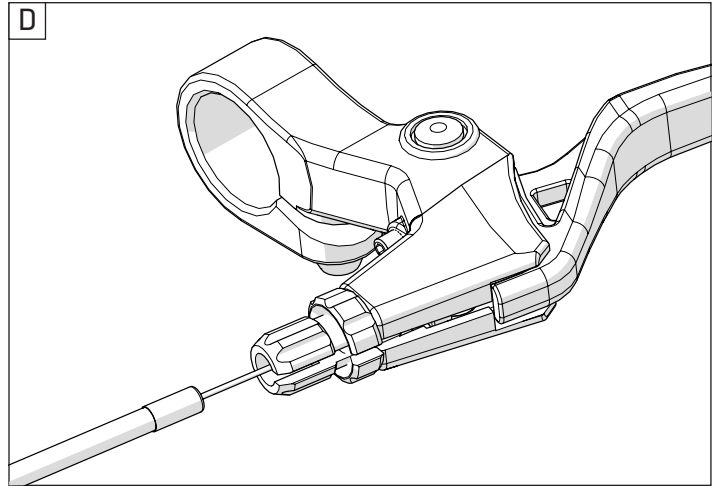
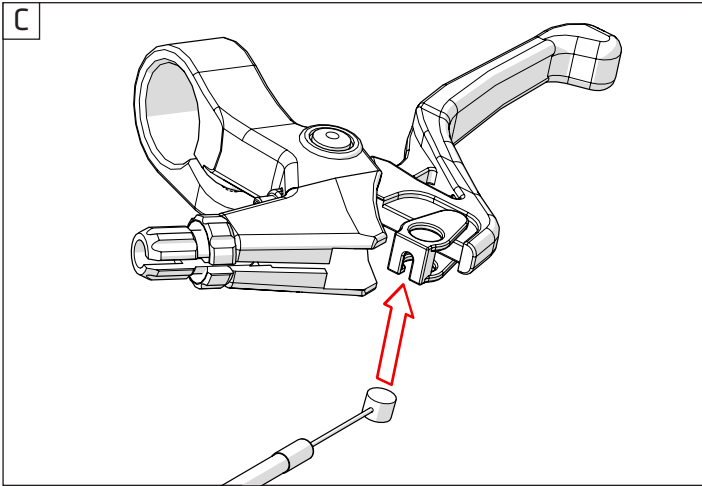
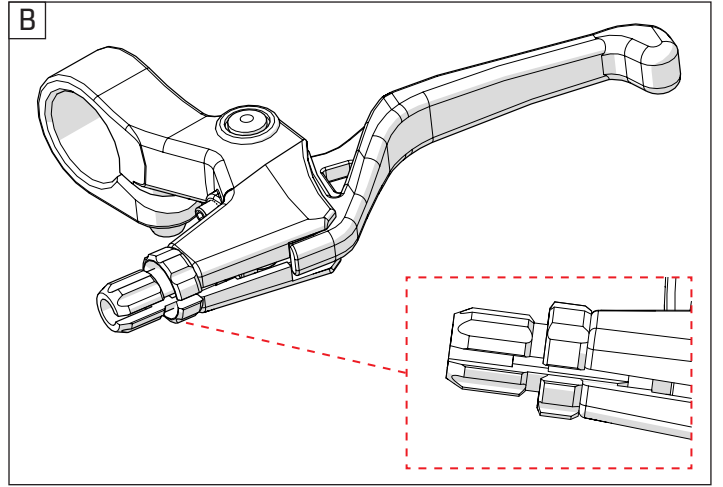
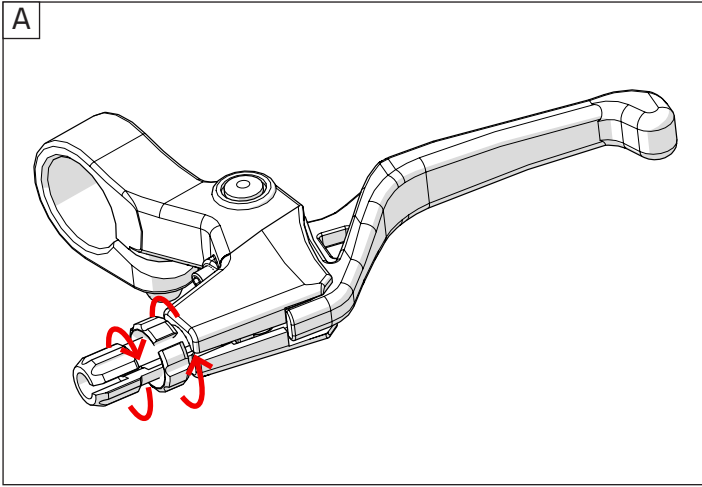



71

ride B-TRIKE

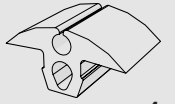

4x

Brake cable clip

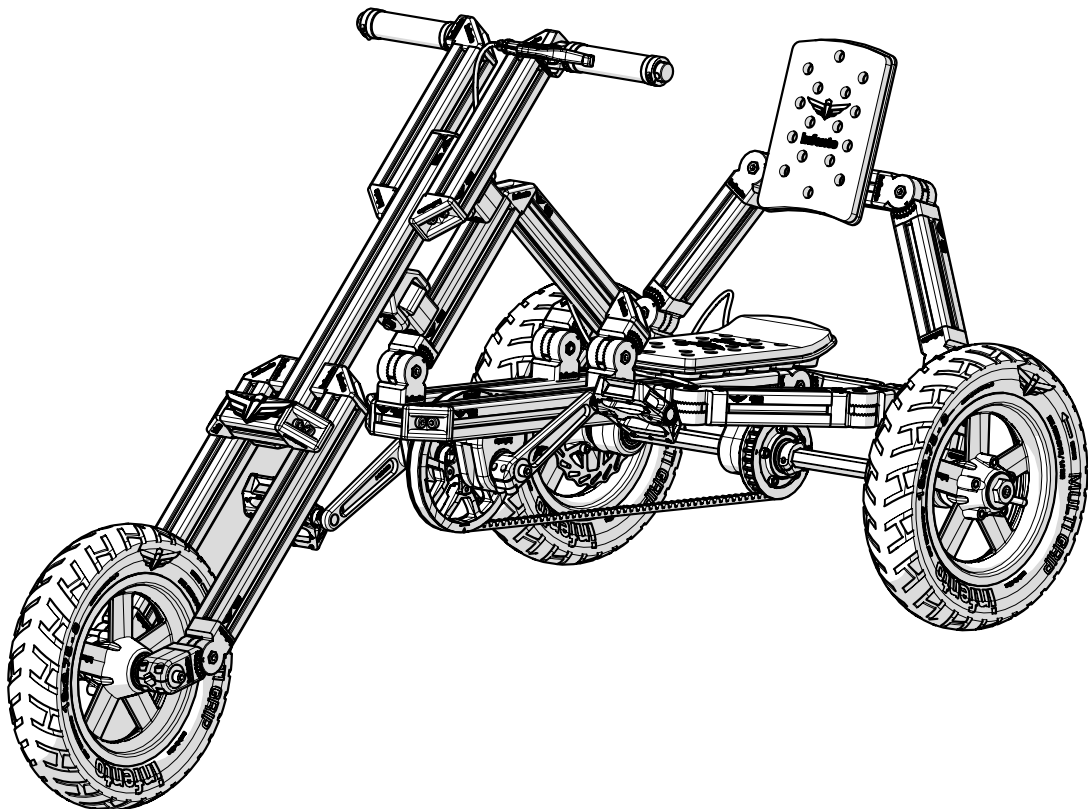
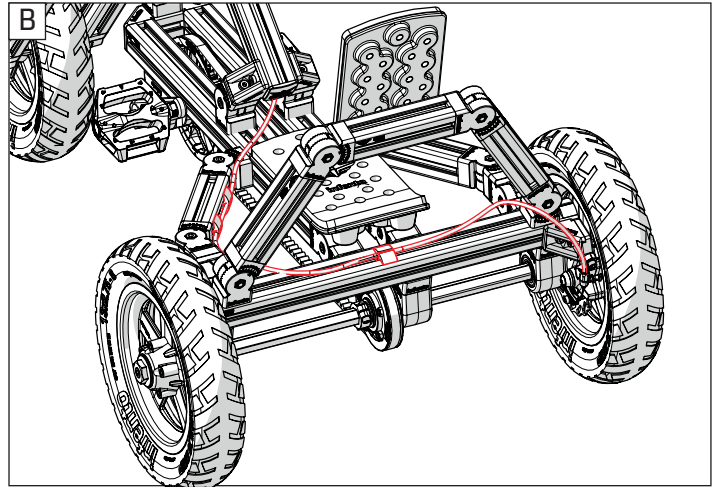
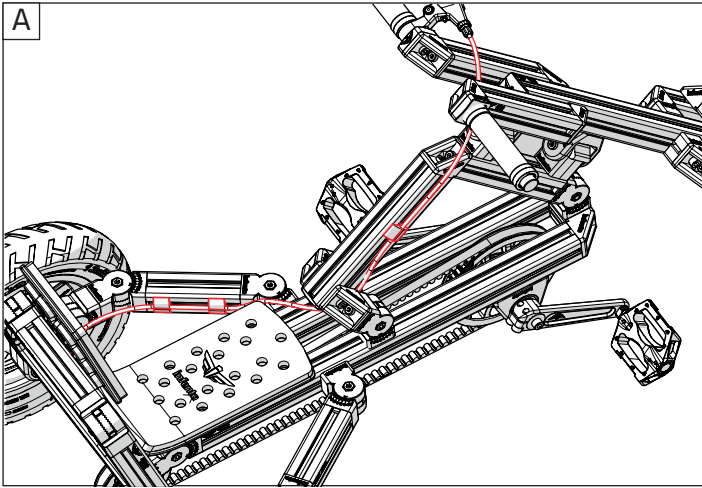



72

ride B-TRIKE

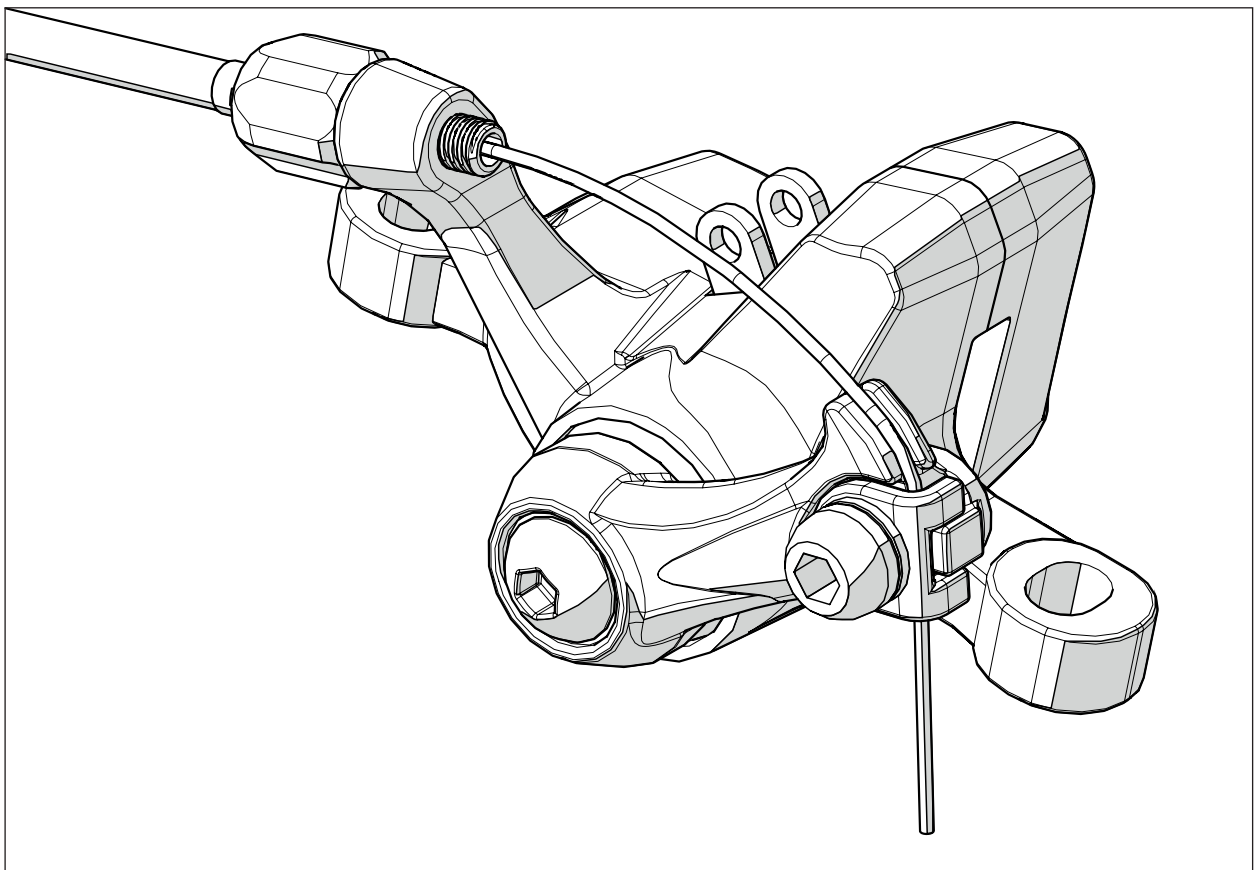
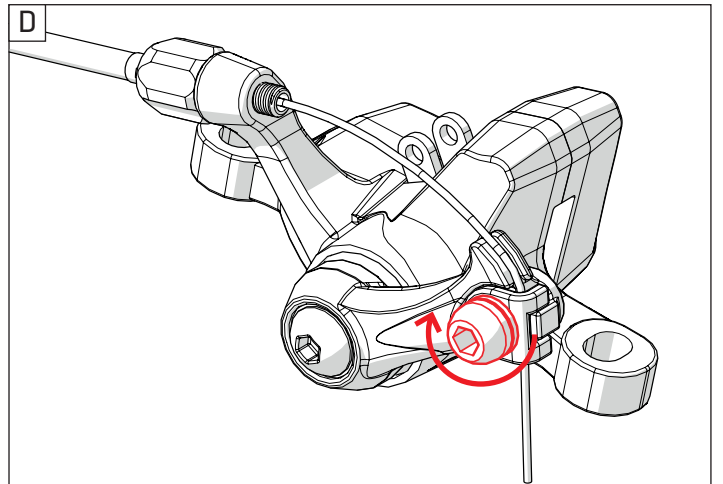
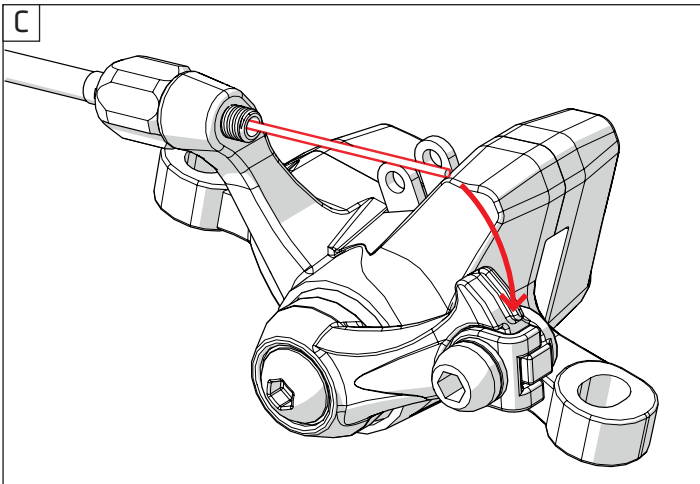
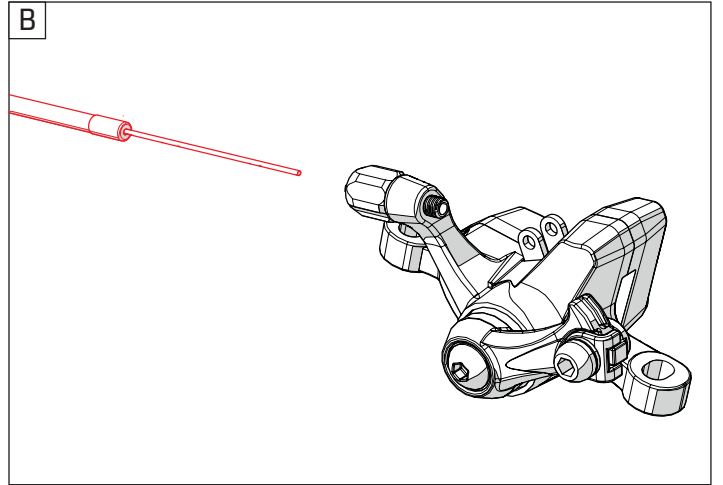
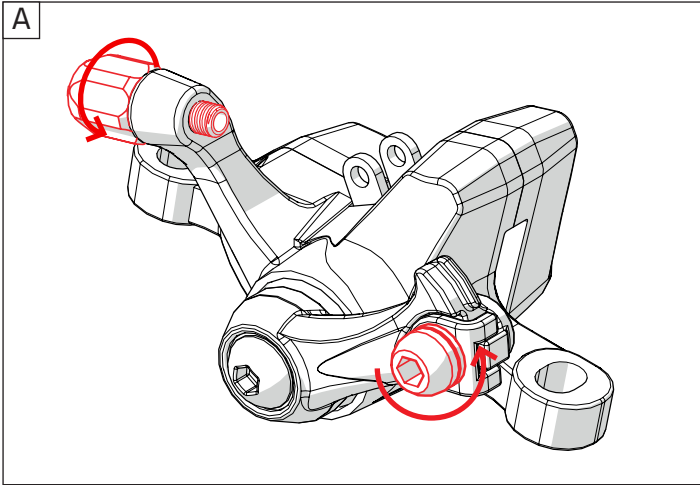

B-TRIKE



THANK YOU FOR READING ME!